



Designation: F1958/F1958M – 99 (Reapproved 2005)

Standard Test Method for Determining the Ignitability of Non-flame-Resistant Materials for Clothing by Electric Arc Exposure Method Using Mannequins¹

This standard is issued under the fixed designation F1958/F1958M; the number immediately following the designation indicates the year of original adoption or, in the case of revision, the year of last revision. A number in parentheses indicates the year of last reapproval. A superscript epsilon (ϵ) indicates an editorial change since the last revision or reapproval.

1. Scope

1.1 This test method is used to identify materials that are ignitable and that can continue to burn when exposed to an electric arc, and determines (a) the incident exposure energy that causes ignition, and (b) the probability of ignition.

1.2 The specimens tested in this test method are materials fabricated in the form of shirts.

1.3 This test method shall be used to measure and describe the properties of materials, products, or assemblies in response to convective and radiant energy generated by an electric arc under controlled laboratory conditions.

1.4 The values stated in either SI units or in other units shall be regarded separately as standard. The values stated in each system may not be exact equivalents, therefore each system must be used independently of the other, without combining values in any way.

1.5 *This standard shall not be used to describe or appraise the fire hazard or fire risk of materials, products, or assemblies under actual fire conditions. However, results of this test may be used as elements of a fire assessment which takes into account all of the factors which are pertinent to an assessment of the fire hazard of a particular end use.*

1.6 *This standard does not purport to address all of the safety concerns, if any, associated with its use. It is the responsibility of the user of this standard to establish appropriate safety and health practices and determine the applicability of regulatory limitations prior to use.*

1.7 For specific precautions, see Section 7.

2. Referenced Documents

2.1 *ASTM Standards:*²

[D123 Terminology Relating to Textiles](#)

¹ This test method is under the jurisdiction of ASTM Committee F-18 on Electrical Protective Equipment for Workers and is the direct responsibility of Subcommittee F18.65 on Wearing Apparel.

Current edition approved March 1, 2005. Published April 2005. Originally approved in 1997 as PS 57–97. Last previous edition approved in 1999 as F1958/F1958M-99. DOI: 10.1520/F1958_F1958M-99R05.

² For referenced ASTM standards, visit the ASTM website, www.astm.org, or contact ASTM Customer Service at service@astm.org. For *Annual Book of ASTM Standards* volume information, refer to the standard's Document Summary page on the ASTM website.

[D4391 Terminology Relating to The Burning Behavior of Textiles](#)

[F1494 Terminology Relating to Protective Clothing](#)

[F1506 Performance Specification for Flame Resistant Textile Materials for Wearing Apparel for Use by Electrical Workers Exposed to Momentary Electric Arc and Related Thermal Hazards](#)

[F1959/F1959M Test Method for Determining the Arc Rating of Materials for Clothing](#)

2.2 *ANSI/IEEE Standards:*³

Standard Dictionary of Electrical and Electronics Terms³

3. Terminology

3.1 *Definitions:*

3.1.1 See also Terminology [D4391](#).

3.1.2 *arc duration, n*—time duration of the arc, s.

3.1.3 *arc energy, vi dt, n*—sum of the instantaneous arc voltage values multiplied by the instantaneous arc current values multiplied by the incremental time values during the arc, J.

3.1.4 *arc gap, n*—distance between the arc electrodes, in.

3.1.5 *arc voltage, n*—voltage across the gap caused by the current flowing through the resistance created by the arc gap, V.

3.1.6 *asymmetrical arc current, n*—the total arc current produced during closure; it includes a direct component and a symmetrical component, A.

3.1.7 *blowout, n*—the extinguishing of the arc caused by a magnetic field.

3.1.8 *closure, n*—point on supply current wave form where arc is initiated.

3.1.9 *delta peak temperature, n*—difference between the maximum temperature and the initial temperature of the sensor during the test, °C.

3.1.10 *heatflux, n*—the thermal intensity indicated by the amount of energy transmitted per unit area and time (cal/cm²s)(W/cm²).

³ Available from the Institute of Electrical and Electronic Engineers, Inc., 345 E. 47th St., New York, NY 10017.

3.1.11 i^2t , n —sum of the instantaneous arc current values squared multiplied by the incremental time values during the arc, A^2/s .

3.1.12 *ignitability, n (ignitable, adj)*—in electric arc exposure, the property of a material involving ignition accompanied by heat and light, and continued burning resulting in consumption of at least 25 % of the exposed area of the test specimen.

3.1.13 *ignition, n* —the initiation of combustion.

3.1.14 *incident energy (E_i), n* —the amount of energy (total heat, cal/cm^2) received at a surface as a direct result of an electrical arc discharge as measured by temperature rise on copper calorimeters.

3.1.15 *incident energy monitoring sensors*—sensors mounted on each side of the mannequins.

3.1.15.1 *Discussion*—Sensors use the calorimeters described in Test Method F1959/F1959M.

3.1.16 *peak arc current, n* —maximum value of the AC arc current, A.

3.1.17 *RMS arc current, n* —root mean square of the AC arc current, A.

3.1.18 *time to delta peak temperature, n* —the time from beginning of the initiation of the arc to the time the delta peak temperature is reached, s.

3.1.19 *X/R ratio, n* —the ratio of system inductive reactance to resistance. It is proportional to the L/R ratio of time constant, and is, therefore, indicative of the rate of decay of any DC offset. A large X/R ratio corresponds to a large time constant and a slow rate of decay.

3.2 For definitions of other textile terms used in this test method, refer to Terminologies D123 and F1494.

4. Summary of Test Method

4.1 This test method exposes a material to heat energy from an electric arc, and determines (a) the incident exposure energy that causes ignition, and (b) the probability of ignition.

4.1.1 During this procedure, a material is observed for ignitability during and after exposure to an electric arc.

4.2 Material performance is determined from the ignitability of the specimen(s).

5. Significance and Use

5.1 This test method determines the ignitability of materials in single or multiple layers.

5.1.1 Material performance shall be determined from the ignitability of the specimen(s) and shall be reported as a probability of ignition at various incident energy levels.

5.1.2 Materials which meet the flame resistance requirements of Specification F1506 do not require testing by this test method unless the mechanism of passing Specification F1506 involves melting and escape from the flame source (for example, coated fabrics, certain rainwear fabrics).

5.2 This test method maintains the specimen in a static, vertical position and does not involve movement except that resulting from the exposure.

5.3 This test method specifies a standard set of exposure conditions. Different exposure conditions may produce different results. In addition to the standard set of exposure conditions, other conditions representative of the expected hazard may be used.

6. Apparatus

6.1 *General Arrangement for Determining Ignitability Using Mannequins and Monitor Sensors*—The test apparatus shall consist of supply bus, arc controller, recorder, arc electrodes, mannequins, and incident energy monitoring sensors. The arc exposure shall be monitored with two incident energy monitoring sensors for each mannequin.

6.1.1 *Arrangement of the Mannequins*—A minimum of two mannequins with two monitoring sensors each shall be used for each test. Position monitor sensors on each side of the mannequins as shown in Fig. 1. An additional mannequin with monitoring sensors may be placed around the arc as shown in Fig. 2 to evaluate multiple samples of the same materials at the same distance from the arc. Each mannequin shall be visually observed for ignition.

6.1.2 *Specimen Holder*—Use a male mannequin torso, size large, made from non-conductive fiberglass construction. (A mannequin, such as Model 7001 D, Morgese Soriano or equivalent is acceptable). The mannequin shall be constructed in an erect posture. The mannequin head may be removable. The mannequins shall have detachable arms that are straight and mount in a vertical position to allow the test specimen at the chest to be the closest point to the centerline of the arc. The arms of the mannequins may be shortened to 4 in. [102 mm] to permit ease of specimen mounting. The position of the mannequins from the centerline of the arc electrodes shall be adjustable from 8 in. [203 mm] to 24 in. [610 mm] as shown in Figs. 1 and 3.

6.1.3 The mannequins may be instrumented. Refer to Appendix X1.

6.2 *Supply Bus and Electrodes*—A typical arrangement of the supply bus and arc electrodes is shown in Fig. 2. The arc shall be in a vertical position as shown.

6.2.1 *Electrodes*—Make the electrodes from stainless steel (Alloy Type 303 or Type 304) rod of a nominal $3/4$ -in. [19-mm] diameter. Lengths of 18 in. [450 mm] long initially have been found to be adequate.

6.2.2 *Fuse Wire*—A fuse wire, connecting the ends of opposing electrodes tips, is used to initiate the arc. This wire is consumed during the test; therefore, its mass shall be very

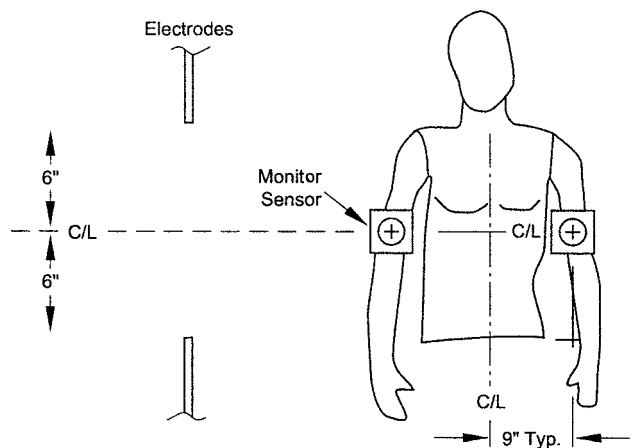

FIG. 1 Mannequin With Monitor Sensors

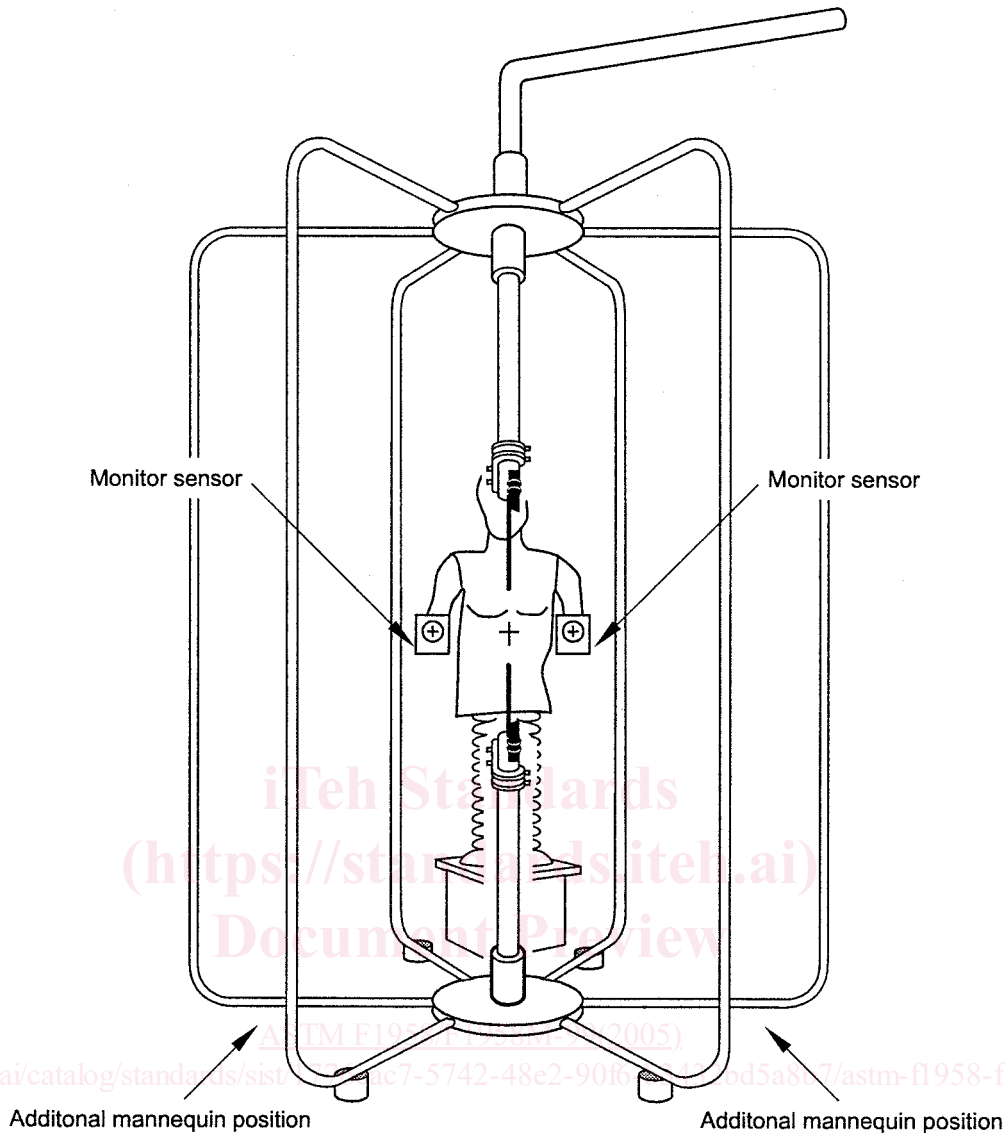

FIG. 2 Supply Bus and Arc Electrodes Showing Mannequin(s) Position(s)

small to reduce the chance of molten metal burns. The fuse wire shall be a copper wire with a diameter no greater than 0.02 in. [0.05 mm].

6.3 *Electric Supply*—The electric supply should be sufficient to allow for the discharge of an electric arc with a gap of up to 12 in. [305 mm], with alternating arc current from 4000 up to 25 000 amperes and with arc duration from 3 cycles [0.05 s] up to 90 cycles [1.5 s] from a 60 Hz supply. The X/R ratio of the test circuit shall be such that the test current contains a DC component resulting in the first peak of the test current having a magnitude of 2.3 times the symmetrical RMS value.

6.4 *Test Circuit Control*—Repeat exposures of the arc currents shall not deviate more than 2 % per test from the selected test level. The make switch shall be capable of point on wave closing within 0.2 cycles from test to test, such that the closing angle will produce maximum asymmetrical current with an X/R ratio of the test circuit as stated in 6.3. The arc current, duration, and voltage shall be measured. The arc, current,

duration, voltage and energy shall be displayed in graph form and stored in digital format.

6.5 *Data Acquisition System*—The system shall be capable of recording voltage, current, and sufficient calorimeter outputs as required by the test. The sensitivity and accuracy of the data acquisition system shall be as described in Test Method F1959/F1959M.

6.6 *Data Acquisition System Protection*—Due to the nature of this type of testing, the use of isolating devices on the calorimeter outputs to protect the acquisition system is recommended.

7. Precautions

7.1 The test apparatus discharges large amounts of energy. In addition, the electric arc produces very intense light. Care should be taken to protect personnel working in the area. Workers should be behind protective barriers or at a safe distance to prevent electrocution and contact with molten

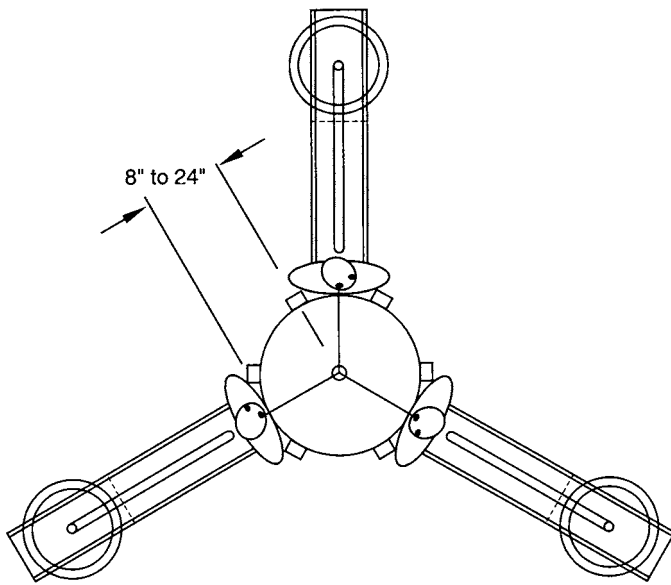

FIG. 3 Arrangement of Mannequin(s)

metal. Workers wishing to directly view the test should use very heavily tinted glasses such as ANSI/ASC Filter Shade 12 welding glasses. If the test is conducted indoors, there shall be a means to ventilate the area to carry away combustion products, smoke, and fumes. Air currents can disturb the arc, reducing the heatflux at the surface of any of the calorimeters. The test apparatus should be shielded by non-combustible materials suitable for the test area. Outdoor tests shall be conducted in a manner appropriate to prevent exposure of the test specimen to moisture and wind (the elements). The leads to the test apparatus should be positioned to prevent blowout of the electric arc. The test apparatus should be insulated from ground for the appropriate test voltage.

7.2 The test apparatus, electrodes and calorimeter assemblies become hot during testing. Use protective gloves when handling these hot objects.

7.3 Use care when the specimen ignites or releases combustible gases. An appropriate fire extinguisher should be readily available. Ensure all materials are fully extinguished.

7.4 Immediately after each test, the electric supply shall be shut off from the test apparatus and all other lab equipment used to generate the arc. The apparatus and other laboratory equipment shall be isolated and grounded. After data acquisition has been completed, appropriate methods shall be used to ventilate the test area before it is entered by personnel. No one should enter the test area prior to exhausting all smoke and fumes.

8. Sampling and Specimen Preparation

8.1 *Test Specimens for Mannequin Test*—From the material to be tested, make specimens according to standards for large men’s long sleeve shirts. Body measurements in inches are: neck size, 16 ½; chest, 44; waist, 39; hip, 45; and sleeve length 34. Reference McCall’s pattern No. 4641 size 16 ½. Front pockets are to be eliminated.

8.1.1 The fabric direction shall be that normally used for constructing shirts.

8.2 Conditioning of Test Specimens:

8.2.1 Launder the required number of test specimens.

8.2.1.1 Launder three times in a washing machine using commercially available detergent without chlorine bleach and with a warm 120°F (50°C) water setting.

NOTE 1—Drying is not required following the first two launderings.

8.2.1.2 Following the three laundering cycles, tumble dry in a dryer on a setting appropriate for the fabric. Remove specimens when dry.

8.2.1.3 Samples may be restored to a flat condition by pressing.

8.2.2 For those materials that require cleaning other than laundering, follow the manufacturer’s recommended practice and note the procedure used in the test reports.

9. Calibration and Standardization

9.1 *Data Collection System Precalibration*—The data collection system shall be calibrated by using a thermocouple calibrator/simulator. This will allow calibrations to be made at multiple points and at levels above 100°C. Due to the nature of the tests frequent calibration checks are recommended.

9.2 *Calorimeter Calibration Check*—Calorimeters shall be checked to verify proper operation. Measure and graph the temperature rise of each calorimeter and system response. At 30 s no one calorimeter response shall vary by more than 4°C from the average of all calorimeters. Any calorimeter not meeting this requirement shall be suspected of faulty connections and shall be replaced or repaired.

NOTE 2—One acceptable method is to expose each calorimeter to a fixed radiant energy source for 30s. For example, place the front surface of a 500 W spot light 10.5 in. from the calorimeter. The spot shall be centered on and perpendicular to the calorimeter.⁴

9.3 *Arc Exposure Calibration*—Prior to each calibration, position the electrodes of the test apparatus to produce a 12-in. [305-mm] gap. The face of the monitor sensors shall be parallel and normal to the centerline of the electrodes. The midpoint of the electrode gap shall be at the same elevation as the center point of the monitor sensors (see Fig. 1). Connect the fuse wire to the end of one electrode by making several wraps and twists and then to the end of the other electrode by the same method. The fuse wire shall be pulled tight and the excess trimmed. The test controller should be adjusted to produce the desired arc current and duration.

9.4 *Apparatus Calibration Check*—Position each monitor sensor so that the surface of each sensor is 12 in. [305 mm] from, parallel and normal to the centerline of the electrodes. Set the symmetrical arc exposure current to the test amperage level and the arc duration at 10 cycles [0.167 s]. Discharge the arc. Determine the maximum temperature rise for each of the sensors, and multiply by the sensor constant 0.135 (cal/cm² C) to obtain the incident energy (total heat) (cal/cm²) measured by each sensor. Compare the highest sensor reading and the average value obtained for all sensors. For example, with the measured result of 10.1 cal/cm² for the calibration exposure of

⁴ A 500-W light source is available from the Strand Electric and Engineering Co. Ltd. as Part No. 83 (500 W, 120 V light source).