



Designation: D720 – 91 (Reapproved 2004)^{ε1}

Standard Test Method for Free-Swelling Index of Coal¹

This standard is issued under the fixed designation D720; the number immediately following the designation indicates the year of original adoption or, in the case of revision, the year of last revision. A number in parentheses indicates the year of last reapproval. A superscript epsilon (ϵ) indicates an editorial change since the last revision or reapproval.

This standard has been approved for use by agencies of the Department of Defense.

^{ε1} NOTE—Section 1.2 was editorially inserted in March 2005.

1. Scope

1.1 This test method² is a small-scale test for obtaining information regarding the free-swelling properties of a coal. The results may be used as an indication of the caking characteristic of the coal when burned as a fuel. This test is not recommended as a method for the determination of expansion of coals in coke ovens.

1.2 **Warning**—Breathing of asbestos dust is hazardous. Asbestos and asbestos products present demonstrated health risks for users and for those with whom they come into contact. In addition to other precautions, when working with asbesto-cement products, minimize the dust that results. For information on the safe use of chrysotile asbestos, refer to, Safe Use of Chrysotile Asbestos: A Manual on Preventive and Control Measures.³

1.3 The values stated in SI units are to be regarded as the standard. The values given in parentheses are for information only.

1.4 *This standard does not purport to address all of the safety concerns, if any, associated with its use. It is the responsibility of the user of this standard to establish appropriate safety and health practices and determine the applicability of regulatory limitations prior to use.*

¹ This test method is under the jurisdiction of ASTM Committee D05 on Coal and Coke and is the direct responsibility of Subcommittee D05.15 on Metallurgical Properties of Coal and Coke.

Current edition approved April 1, 2004. Published May 2004. Originally approved in 1943. Last previous edition approved in 1999 as D720 – 91 (1999). DOI: 10.1520/D0720-91R04E01.

² This test method is an adaptation of the Crucible Swelling Test for Coal of the British Standards Institution. For information concerning the experimental work on which this adaptation is based, see paper by Ostborg, H. N., Limbacker, H. R., and Sherman, R. A., "An Experimental Investigation of the British Standard Method for the Crucible Swelling Test for Coal," *Proceedings, Am. Soc. Testing Mats.*, Vol 42, 1042, p. 851. See also a paper by Selvig, W. A., and Ode, W. H., "An Investigation of a Laboratory Test for Determination of the Free-Swelling Index of Coal," *U.S. Bureau of Mines Report of Investigation 4238*, Revision of R. I. 3989, 1948.

³ Chrysotile Institute 1200, McGill College Suite 1640 Montreal, Quebec Canada H3B 4G7

2. Referenced Documents

2.1 *ASTM Standards*:⁴

D2013 Practice for Preparing Coal Samples for Analysis

3. Significance and Use

3.1 This test method, in addition to indicating the caking properties of a coal when burned as a fuel, can be used to give a broad indication of the degree of oxidation of a coal.

4. Apparatus

4.1 This test method can be made with either electric or gas heating. When using electric heating, the results obtained must be the same as those obtained when using the gas heating method. The apparatus common to both electric and gas methods shall consist of the following:

4.1.1 *Crucible*, translucent silica, low-form, with a flat, close-fitting silica ring-handle lid and an extra pierced lid for use in determining the crucible temperature, conforming to the following requirements:

Weight, g	11.0 to 12.75
External height, mm	26 ± 0.5
External diameter at top, mm	41 ± 0.75
Internal diameter at base, min, mm	11
Capacity (approximate), cm ³	17

4.1.2 *Sight Tube*, as shown in Fig. 1, for viewing the coke buttons so that the effect of parallax will be eliminated. Make the tube of any rigid and preferably opaque material and support vertically on a ring stand.

4.1.3 *Thermocouple and Potentiometer*.

4.1.4 *Weight*, 500 g.

4.2 The electric apparatus shall consist of the following:

4.2.1 *Furnace*, consisting of a base, a heating element, and a chimney. The unit is shown in Fig. 2.

⁴ For referenced ASTM standards, visit the ASTM website, www.astm.org, or contact ASTM Customer Service at service@astm.org. For *Annual Book of ASTM Standards* volume information, refer to the standard's Document Summary page on the ASTM website.

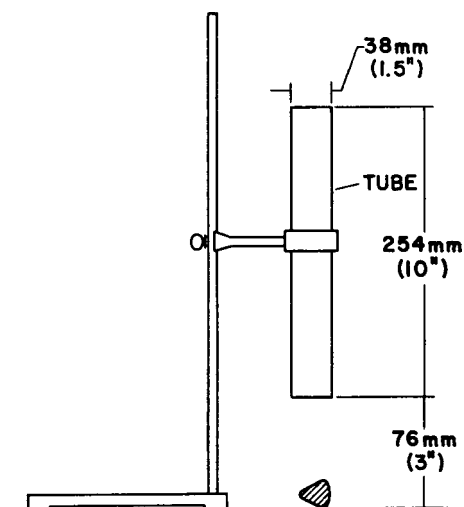

FIG. 1 Sight Tube

4.2.1.1 *Chimney*—Fig. 2 shows the chimney design. Make the unit from firebrick and coat with firebrick bonding mortar. Maintain the chimney under compression by a sheet-metal envelope (Fig. 2) to prevent cracking. Make the envelope in four pieces, each piece covering a corner. The pieces shall overlap at the center of the flat faces and be held together by bolts and springs. Place two layers of asbestos paper between the chimney brick and the envelope. Cut two grooves in the upper inside chimney walls to accommodate the crucible support. In cases in which the furnace is located in a drafty area, it is advisable to shield the chimney to prevent large fluctuations in furnace temperature.

4.2.2 *Crucible Support*—A convenient crucible support consists of a cradle support made from nickel-chromium wire suspended from a metal ring. The height of the support inside the furnace can be adjusted by loosening the two screws that hold the wire legs of the support in place.

4.2.3 *Electric Controls*, consisting of a rheostat, an ammeter, and two timers. These components shall conform to the following specifications:

Ammeter	a-c, 0 to 10-A range
Rheostat	100 W, 10 Ω
Variable transformer	7.4 A, 120 V
Timer	mechanical, 0–5 min minimum span, with a hold position, and electrical contact closed during timing cycle

4.2.3.1 One timer shall actuate the rheostat, at a predetermined setting, after 1½ min of operation. Preset the rheostat to reduce the rate of heating of the furnace so that a temperature of 820 ± 5°C (1508 ± 9°F) is achieved at the end of 2½ min. A variable transformer is desirable for establishing the input voltage to the furnace.

4.3 The gas apparatus shall consist of the following:

4.3.1 *Burner Assembly*—A gas burner with a grid of external diameter, 30 to 42 mm (1.18 to 1.65 in.), a draft shield, and a triangular crucible support as shown in Fig. 3. Make the draft shield, conforming to the dimensions shown in Fig. 3 from the asbestos-cement pipe, and at the top it shall have three slots, 25 mm (1 in.) in depth, in which the wires of the crucible support rest. Support the draft shield on a ring stand, so that the

distance between the base of the crucible and the top of the burner grid may be adjusted by raising or lowering the draft shield. Make the triangular crucible support from three pieces of translucent silica tubing each 63 mm (2.5 in.) in length, 6 to 6.5 mm (0.24 to 0.26 in.) in external diameter, and mounted on chromium-nickel wire so that the diameter of the inscribed circle is approximately 32 mm (1.26 in.). The twisted ends of the triangle may be joined together by a loop of wire to facilitate removal of the hot crucible.

4.3.2 *Flowmeter*—A capillary flowmeter with water manometer placed in the gas line before the burner as a guide to the control of the rate of gas flow (Fig. 3).

5. Calibration

5.1 Electric Furnace:

5.1.1 Turn the main power switch on and set the timer to the HOLD position. Adjust the variable transformer so that the ammeter reads 5.8 A. Allow at least 45 min for the furnace temperature to reach equilibrium.

5.1.2 Set the timer just beyond the 1½-min mark. At 1½ min, lower an empty crucible with pierced lid into the furnace. Measure the temperature at the inside base of the crucible with a thermocouple and a potentiometer. The unprotected junction of the thermocouple must be in contact with the inside base of the crucible. At the end of 1½ min, the temperature should read 800 ± 10°C (1472 ± 18°F). Adjust the variable transformer as necessary to provide this temperature.

5.1.3 A temperature of 820 ± 5°C (1508 ± 9°F) must be attained at the end of 2½ min. The second timer shall be used here. The control unit rheostat must be properly adjusted to reduce the heating rate at the end of 2½ min. If the rheostat is set initially so that at the end of 1½ min the ammeter reading is reduced by 0.6 or 0.7 A, the specified temperature at the end of 2½ min should be attained. Several trials will no doubt be necessary before the proper temperatures at 1½ and 2½ min are reached; however, the information given above provides a general guide for calibration. The silica crucible and cover must be at room temperature before each calibration run.

5.1.4 After each calibration attempt or sample run, switch the timer to the HOLD position, and allow about 1 min for the furnace to reach equilibrium.

5.2 Gas Burner:

5.2.1 With the burner assembly arranged as shown in Fig. 3, and with an empty crucible in position, light the burner about 15 min before making a determination to allow the draft shield to rise to an equilibrium temperature.

5.2.2 After placing a crucible in position adjust the flow of gas and the relative positions of the burner and the draft shield so that the temperature of the inner surface of the bottom of the crucible reaches 800 ± 10°C (1472 ± 18°F) in 1½ min and 820 ± 5°C (1508 ± 9°F) in 2½ min. These desired temperatures may usually be obtained by setting the draft shield so that the bottom of the crucible is approximately 10 mm (0.4 in.) above the burner grid, and then adjusting the gas flame. Determine the crucible temperature by means of a thermocouple and a potentiometer. Insert the thermocouple through the pierced crucible lid so that the unprotected junction of the thermocouple is in contact with the base of the crucible.