Stationary training equipment —

Part 4:

**Strength training benches, additional
specific safety requirements and test
methods**

iTeh STANDARD PREVIEW

Équipement d'entraînement fixe —

(standards.iteh.ai)

*Partie 4: Bancs pour haltères — Exigences spécifiques de sécurité et
méthodes d'essai supplémentaires*

ISO 20957-4:2005

<https://standards.iteh.ai/catalog/standards/sist/f674c94d-8bb4-43b7-a7bb-dfda6ac4da8f/iso-20957-4-2005>



PDF disclaimer

This PDF file may contain embedded typefaces. In accordance with Adobe's licensing policy, this file may be printed or viewed but shall not be edited unless the typefaces which are embedded are licensed to and installed on the computer performing the editing. In downloading this file, parties accept therein the responsibility of not infringing Adobe's licensing policy. The ISO Central Secretariat accepts no liability in this area.

Adobe is a trademark of Adobe Systems Incorporated.

Details of the software products used to create this PDF file can be found in the General Info relative to the file; the PDF-creation parameters were optimized for printing. Every care has been taken to ensure that the file is suitable for use by ISO member bodies. In the unlikely event that a problem relating to it is found, please inform the Central Secretariat at the address given below.

iTeh STANDARD PREVIEW
(standards.iteh.ai)

[ISO 20957-4:2005](https://standards.iteh.ai/catalog/standards/sist/f674c94d-8bb4-43b7-a7bb-dfda6ac4da8f/iso-20957-4-2005)

<https://standards.iteh.ai/catalog/standards/sist/f674c94d-8bb4-43b7-a7bb-dfda6ac4da8f/iso-20957-4-2005>

© ISO 2005

All rights reserved. Unless otherwise specified, no part of this publication may be reproduced or utilized in any form or by any means, electronic or mechanical, including photocopying and microfilm, without permission in writing from either ISO at the address below or ISO's member body in the country of the requester.

ISO copyright office
Case postale 56 • CH-1211 Geneva 20
Tel. + 41 22 749 01 11
Fax + 41 22 749 09 47
E-mail copyright@iso.org
Web www.iso.org

Published in Switzerland

Foreword

ISO (the International Organization for Standardization) is a worldwide federation of national standards bodies (ISO member bodies). The work of preparing International Standards is normally carried out through ISO technical committees. Each member body interested in a subject for which a technical committee has been established has the right to be represented on that committee. International organizations, governmental and non-governmental, in liaison with ISO, also take part in the work. ISO collaborates closely with the International Electrotechnical Commission (IEC) on all matters of electrotechnical standardization.

International Standards are drafted in accordance with the rules given in the ISO/IEC Directives, Part 2.

The main task of technical committees is to prepare International Standards. Draft International Standards adopted by the technical committees are circulated to the member bodies for voting. Publication as an International Standard requires approval by at least 75 % of the member bodies casting a vote.

Attention is drawn to the possibility that some of the elements of this document may be the subject of patent rights. ISO shall not be held responsible for identifying any or all such patent rights.

ISO 20957-4 was prepared by CEN (as EN 957-4) and was adopted, under a special “fast-track procedure”, by Technical Committee ISO/TC 83, *Sports and recreational equipment*, in parallel with its approval by the ISO member bodies.

ISO 20957 consists of the following parts, under the general title *Stationary training equipment*:

- *Part 1: General safety requirements and test methods*
- *Part 2: Strength training equipment, additional specific safety requirements and test methods*
- *Part 4: Strength training benches, additional specific safety requirements and test methods*
- *Part 5: Pedal crank training equipment, additional specific safety requirements and test methods*
- *Part 6: Treadmills, additional specific safety requirements and test methods*
- *Part 7: Rowing machines, additional specific safety requirements and test methods*
- *Part 8: Steppers, stairclimbers and climbers — Additional specific safety requirements and test methods*
- *Part 9: Elliptical trainers, additional specific safety requirements and test methods*

Contents

Foreword	3
Introduction	4
1 Scope.....	5
2 Normative references	5
3 Definitions.....	5
4 Classification.....	5
5 Safety requirements.....	5
6 Test methods.....	7
7 Additional instructions for use.....	8

iTeh STANDARD PREVIEW (standards.iteh.ai)

[ISO 20957-4:2005](https://standards.iteh.ai/catalog/standards/sist/f674c94d-8bb4-43b7-a7bb-dfda6ac4da8f/iso-20957-4-2005)

<https://standards.iteh.ai/catalog/standards/sist/f674c94d-8bb4-43b7-a7bb-dfda6ac4da8f/iso-20957-4-2005>

Foreword

This European Standard has been prepared by the Technical Committee CEN/TC 136, "Sports, playground and other recreational equipment", the secretariat of which is held by DIN.

This European Standard shall be given the status of a national standard, either by publication of an identical text or by endorsement, at the latest by November 1996, and conflicting national standards shall be withdrawn at the latest by November 1996.

This standard consists of the following parts:

EN 957-1: *General safety requirements and test methods.*

EN 957-2: *Strength training equipment, additional specific safety requirements and test methods.*

EN 957-4: *Strength training benches, additional specific safety requirements and test methods.*

EN 957-5: *Pedal crank training equipment, additional specific safety requirements and test methods.*

prEN 957-6: *Tread mills, additional specific safety requirements and test methods.*

prEN 957-7: *Rowing machines, additional specific safety requirements and test methods.*

prEN 957-8: *Stair climbers and steppers, additional specific safety requirements and test methods.*

This part of EN 957 should be read in conjunction with EN 957-1.

The design of strength training benches need not comply with the figures in this part of EN 957.

<https://standards.iteh.ai/catalog/standards/sist/674c94d-8bb4-43b7-a7bb->

According to the CEN/CENELEC Internal Regulations, the national standards organizations of the following countries are bound to implement this European Standard: Austria, Belgium, Denmark, Finland, France, Germany, Greece, Iceland, Ireland, Italy, Luxembourg, Netherlands, Norway, Portugal, Spain, Sweden, Switzerland and the United Kingdom.

ISO 20957-4:2005(E)

EN 957-4:1996 (E)

Introduction

This part of EN 957 concerns the safety of strength training benches.

It amends and supplements prEN 957-1. The requirements of this specific standard take priority over those in the general standard.

iTeh STANDARD PREVIEW (standards.iteh.ai)

[ISO 20957-4:2005](https://standards.iteh.ai/catalog/standards/sist/f674c94d-8bb4-43b7-a7bb-dfda6ac4da8f/iso-20957-4-2005)

<https://standards.iteh.ai/catalog/standards/sist/f674c94d-8bb4-43b7-a7bb-dfda6ac4da8f/iso-20957-4-2005>

1 Scope

This part of EN 957 specifies safety requirements for stationary strength training benches and free-standing barbell racks used to perform exercises during use in addition to the general safety requirements of prEN 957-1.

This part of EN 957 is applicable to stationary training equipment type benches (type 4) (hereinafter referred to as benches) with the classes S and H.

2 Normative references

This European Standard incorporates by dated or undated reference, provisions from other publications. These normative references are cited at the appropriate places in the text and the publications are listed hereafter. For dated references, subsequent amendments to or revisions of any of these publications apply to this European Standard only when incorporated in it by amendment or revision. For undated references the latest edition of the publication referred to applies.

prEN 957-1:1996, *Stationary training equipment — Part 1: General safety requirements and test methods*.

prEN 957-2:1996, *Stationary training equipment — Part 2: Strength training equipment, additional specific safety requirements and test methods*.

3 Definitions

For the purposes of this standard the definitions of EN 957-1 apply.

iTeh STANDARD PREVIEW
(standards.iteh.ai)

4 Classification

Clause 4 of EN 957-1:1996 applies.

[ISO 20957-4:2005](https://standards.iteh.ai/catalog/standards/sist/8674c94d-8bb4-43b7-a7bb-dfda6ac4da8f/iso-20957-4-2005)

5 Safety requirements

<https://standards.iteh.ai/catalog/standards/sist/8674c94d-8bb4-43b7-a7bb-dfda6ac4da8f/iso-20957-4-2005>

5.1 General

Depending on the design of the piece of training equipment the following requirements shall apply as appropriate.

5.2 Benches with fixed barbell supports

5.2.1 Rotational stability of the barbell

Overturning of the barbell by an unequal load shall be prevented either by the distance between the supports or safety device.

Test in accordance with 6.2.

5.2.2 Rotational stability of benches with fixed barbell supports

Benches with fixed barbell supports shall be stable when loaded with unequal load at right angles to the longitudinal axis.

Test in accordance with 6.3.

5.2.3 Longitudinal stability

Benches with fixed barbell supports shall be stable in the longitudinal direction.

ISO 20957-4:2005(E)

EN 957-4:1996 (E)

Test in accordance with 6.4.

5.3 Free-standing barbell supports in conjunction with benches

Free-standing barbell supports in conjunction with benches shall have a device for connecting to the ground.

Test in accordance with 6.1.2.

5.4 Dimensions of the barbell support

The front part of the support (yoke), when measured with a 30 mm diameter bar, shall have a vertical height of 20 mm to 40 mm (a) above the lowest point of the resting bar and the rear part shall be at least 80 mm higher than the top of the front of the support (yoke) (see figure 1).

Dimensions in millimetres

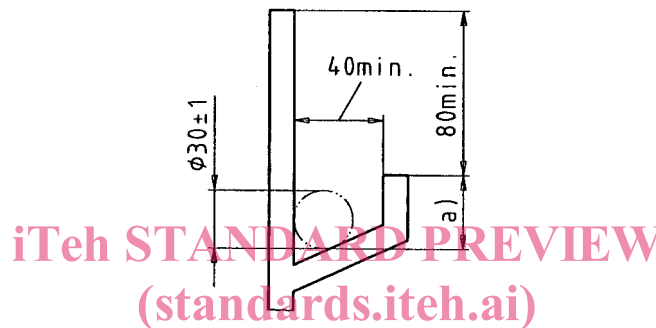

iTeh STANDARD PREVIEW
(standards.iteh.ai)

Key
a) 20 to 40

<https://standards.iteh.ai/catalog/standards/sist/f674c94d-8bb4-43b7-a7bb-dfda6ac4da8f/iso-20957-4-2005>

Figure 1 — Dimensions of the barbell support

Test in accordance with 6.1.1.

5.5 Barbell support strength

The rear part of the barbell support shall absorb the loads of normal use without impairment of the performance and without breakage.

Test in accordance with 6.5.

5.6 Loading

Loading for benches types H and S shall comply with 5.2 of EN 957-2:1996.

5.7 Barbell support

Any part of the equipment intended to support free weights, shall be easily accessible to the user while accepting or replacing the barbell.

Test in accordance with 6.1.4.

6 Test methods

6.1 General

6.1.1 Dimensional check

6.1.2 Visual examination

6.1.3 Tactile examination

6.1.4 Performance test

6.2 Testing of rotational stability of the barbell

Place a solid steel bar (1 600 mm long and a diameter of 30 mm max.) centrally on the barbell supports. Then place one weight disk (10 kg for class H, 20 kg for class S) on one side of the bar with mid-plane of the disk positioned 200 mm from the end of the bar, see figure 2.

Dimensions in millimetres

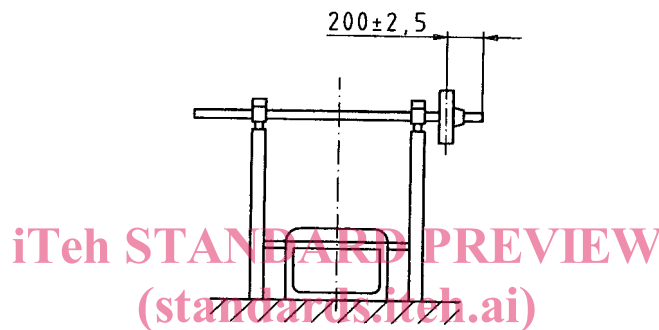

ISO 20957-4:2005
<https://standards.itih.ai/catalog/standards/sist/8674c94d-8bb4-43b7-a7bb-dfda6ac4da8f/iso-20957-4-2005>
Figure 2 — Stability test under unequal load

6.3 Testing of rotational stability of benches with fixed barbell supports

Test as specified in 6.2, but with the barbell fixed.

6.4 Testing of longitudinal stability

Position the bench on a 10° slope and place a barbell loaded in accordance with the manufacturer's maximum load, but with a minimum of 50 kg, on the barbell support in the highest position.

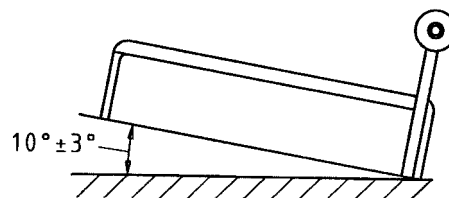

Figure 3 — Stability test in longitudinal direction

6.5 Testing of barbell support strength

Hit the back part of the yoke in a distance of (40 ± 10) mm from the top of that part with the pendulum (see detail figure 4).