

Annulee

ISO

INTERNATIONAL ORGANIZATION FOR STANDARDIZATION

ISO RECOMMENDATION R 163

MAGNETIC STRIPING OF 16 mm FILM
PERFORATED ALONG BOTH EDGES

<https://standards.iteh.ai/catalog/standards/sist/32656651-5d46-421e-b8e7-5672d2020000/iso-r-163-1960>

1st EDITION

July 1960

COPYRIGHT RESERVED

The copyright of ISO Recommendations and ISO Standards belongs to ISO Member Bodies. Reproduction of these documents, in any country, may be authorized therefore only by the national standards organization of that country, being a member of ISO.

For each individual country the only valid standard is the national standard of that country.

Printed in Switzerland

Also issued in French and Russian. Copies to be obtained through the national standards organizations.

BRIEF HISTORY

The ISO Recommendation R 163, *Magnetic Striping of 16 mm Film Perforated Along Both Edges*, was drawn up by Technical Committee ISO/TC 36, *Cinematography*, the Secretariat of which is held by the American Standards Association, Inc. (ASA).

During its second meeting, held in Stockholm, in June 1955, the Technical Committee assigned to its Secretariat the study of a draft proposal for an ISO Recommendation drawn up as recommended by the Working Group No. 4, *Dimensions and Location for Sound Records*, on the basis of the American Standard PH.22.101 (Magnetic coating of 16 mm film perforated along both edges).

In October 1955, this draft proposal for an ISO Recommendation was submitted to the members of the Technical Committee ISO/TC 36 and was adopted as a Draft ISO Recommendation.

On 27 December 1957, the Draft ISO Recommendation (No. 200) was distributed to all the ISO Member Bodies and was approved, subject to some modifications, by the following Member Bodies:

| | | |
|----------------|-------------|----------------|
| Belgium | Italy | Switzerland |
| Burma | Japan | United Kingdom |
| Canada | New Zealand | U.S.A. |
| Czechoslovakia | Portugal | U.S.S.R. |
| Germany | Rumania | |
| Hungary | Sweden | |

One Member Body opposed the approval of the Draft: France.

The Draft ISO Recommendation was then submitted by correspondence to the ISO Council, which decided, in July 1960, to accept it as an ISO RECOMMENDATION.

MAGNETIC STRIPING OF 16 mm FILM PERFORATED ALONG BOTH EDGES

1. SCOPE

This ISO Recommendation specifies the location and dimensions of the magnetic coating material when applied to 16 mm motion-picture film to be used for both picture and sound.

2. DIMENSIONS

The dimensions are as specified in the figure and the table below.

The magnetic coating is on the side of the film toward the lamp in a projector arranged for direct projection on a reflecting screen.

3. SOUND RECORD

The sound record should be placed on track No. 1.

Track No. 2 is provided primarily as a balance stripe, but may be used for a secondary sound record.

STANDARD PREVIEW
(standards.iteh.ai)

ISO/R 163:1960

<https://standards.iteh.ai/catalog/standards/sist/32656651-5d46-421e-b8e7-5672d262cd0d/iso-r-163-1960>

| Dimension | Millimetres | Inches |
|-----------|---------------------------------------------------------|------------------------------------------------------------|
| A | 0.80 $\begin{smallmatrix} +0 \\ -0.1 \end{smallmatrix}$ | 0.031 $\begin{smallmatrix} +0 \\ -0.003 \end{smallmatrix}$ |
| B | max. 0.05 | max. 0.002 |

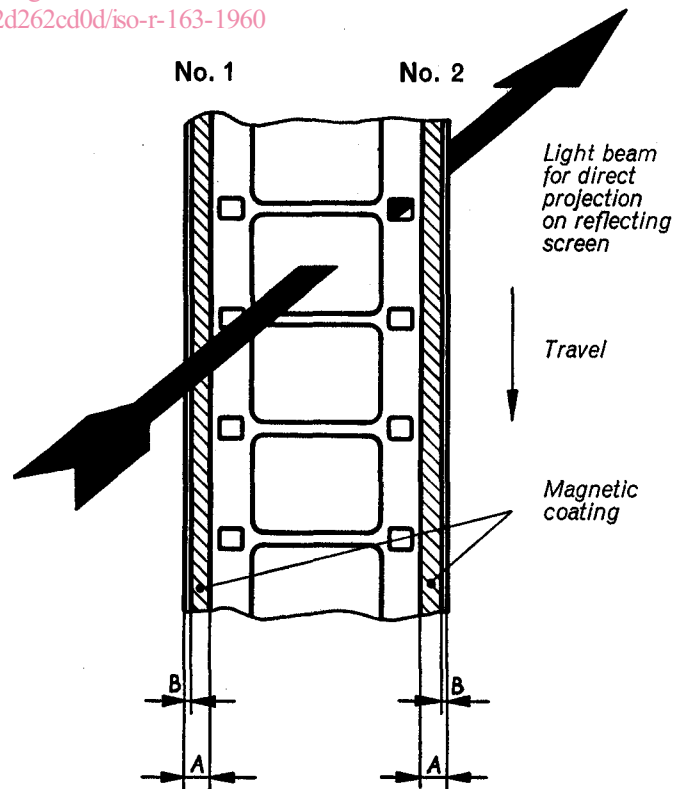

iTeh STANDARD PREVIEW
(standards.iteh.ai)

ISO/R 163:1960

<https://standards.iteh.ai/catalog/standards/sist/32656651-5d46-421e-b8e7-5672d262cd0d/iso-r-163-1960>