



Standard Test Methods for Electrical Performance Properties of Insulations and Jackets for Telecommunications Wire and Cable¹

This standard is issued under the fixed designation D 4566; the number immediately following the designation indicates the year of original adoption or, in the case of revision, the year of last revision. A number in parentheses indicates the year of last reapproval. A superscript epsilon (ϵ) indicates an editorial change since the last revision or reapproval.

1. Scope

1.1 These test methods cover procedures for electrical testing of thermoplastic insulations and jackets used on telecommunications wire and cable and for the testing of electrical characteristics of completed products. To determine the procedure to be used on the particular insulation or jacket compound, or on the end product, reference should be made to the specification for the product.

1.2 The test methods appear in the following sections of this standard:

Test Method	Sections
Electrical Tests of Insulation—In-Process	4-8
DC proof test	8
Insulation defect or fault rate	7
Spark test	6
Electrical Tests of Completed Wire and Cable	9-51
Attenuation	24
Attenuation, effects due to aging	31
Attenuation, effects due to elevated temperature	29
Attenuation, effects due to humidity	30
Attenuation to crosstalk ratio—far end (ACR-F)	28
Attenuation to crosstalk ratio—near end (ACR-N)	26
Capacitance deviation	19
Capacitance difference	20
Capacitance unbalance, Pair-to-ground (CUPG)	22
Capacitance unbalance, Pair-to-pair (CUPP)	21
Capacitance unbalance, Pair-to-support wire	23
Characteristic Impedance—Method 1 Propagation constant and capacitance	47
Characteristic Impedance—Method 2, Single-ended measurements	48
Characteristic Impedance—Method 3 Least Squares Function Fit	49
Coaxial capacitance (capacitance to water)	17
Conductor continuity	11
Conductor resistance (CR)	13
Conductor resistance unbalance (CRU of pairs)	15
Continuity of other metallic elements	12
Crosses test (continuity between wires of different pairs)	35
Crosstalk loss, far-end	27
Crosstalk loss, near-end	25
DC proof test, Core-to-internal shield (screen)	40
DC proof test, Core-to-shield	38
DC proof test, Core-to-support wire	39
DC proof test, Internal shield (screen)-to-shield	41
DC proof test, Other required isolations	42

Test Method	Sections
DC proof test, Wire-to-wire	37
Fault rate test (air core only)	33
Insulation resistance (IR)	32
Jacket voltage breakdown rating test	36
Mutual capacitance (CM)	18
Mutual conductance	16
Phase Constant	44
Phase Delay	45
Phase Velocity	46
Resistance of other metallic cable elements	14
Shorts test (continuity between wires of a pair)	34
Structural Return Loss and Return Loss	50
Unbalance attenuation (conversion losses)	51
Voltage surge test	43

1.3 The values stated in inch-pound units are to be regarded as the standard. SI units are for information only.

1.4 *This standard does not purport to address all of the safety concerns, if any, associated with its use. It is the responsibility of the user of this standard to establish appropriate safety and health practices and determine the applicability of regulatory limitations prior to use.* Specific hazard statements are given in Sections 6 and 37.

2. Referenced Documents

- 2.1 *ASTM Standards:*²
 - B 193** Test Method for Resistivity of Electrical Conductor Materials
 - D 150** Test Methods for A-C Loss Characteristics and Permittivity (Dielectric Constant) of Solid Electrical Insulating Materials
 - D 1711** Terminology Relating to Electrical Insulation
 - D 2633** Test Methods for Thermoplastic Insulations and Jackets for Wire and Cable
 - D 3426** Test Method for Dielectric Breakdown Voltage and Dielectric Strength of Solid Electrical Insulating Materials Using Impulse Waves
 - D 5423** Specification for Forced-Convection laboratory Ovens for Evaluations of Electrical Insulation
 - E 29** Practice for Using Significant Digits in Test Data to Determine Conformance with Specifications

¹ These test methods are under the jurisdiction of ASTM Committee D09 on Electrical and Electronic Insulating Materials and are the direct responsibility of Subcommittee D09.18 on Solid Insulations, Non-Metallic Shieldings, and Coverings for Electrical and Telecommunications Wires and Cables.

Current edition approved March 1, 2005. Published April 2005. Originally approved in 1986. Last previous edition approved in 1998 as D 4566 – 98.

² For referenced ASTM standards, visit the ASTM website, www.astm.org, or contact ASTM Customer Service at service@astm.org. For *Annual Book of ASTM Standards* volume information, refer to the standard's Document Summary page on the ASTM website.

2.2 *ANSI Standard:*

ANSI/IEEE Standard 100 IEEE Standard Dictionary of Electrical and Electronics Terms³

2.3 *IEC Standard:*

IEC 61156-1 Multicore and Symmetrical Pair/Quad Cables for Digital Communications—Part 1: Generic Specification³

2.4 *ITU-T Standard:*

ITU-T Recommendation G117 Transmission Aspects of Unbalance About Earth³

3. Terminology

3.1 *Definitions*—For definitions of terms used in this standard, refer to Terminology **D 1711**.

3.2 *Definitions of Terms Specific to This Standard:*

3.2.1 *air core, n*—refers to products in which the air spaces between cable core components (pairs, etc.) remain in their unfilled or natural state.

3.2.2 *armored wire or cable, n*—wire or cable in which the shielded or jacketed or shielded and jacketed wire or cable is completely enclosed by a metallic covering designed to protect the underlying telecommunications elements from mechanical damage.

3.2.3 *cable, telecommunications, n*—products of six or more pairs.

3.2.4 *filled core, n*—those products in which air spaces are filled with some materials intended to exclude air or moisture, or both.

3.2.5 *low frequency cable, n*—cable used for transmitting signals at a frequency of 2 MHz or less.

3.2.6 *pair, n*—two insulated conductors combined with a twist.

3.2.7 *sheath, n*—the jacket and any underlying layers of shield, armor, or other intermediate material down to but not including the core wrap.

3.2.8 *shielded wire or cable, n*—wire or cable in which the core (or inner jacket) is completely enclosed by a metallic covering designed to shield the core from electrostatic or electromagnetic interference, or both.

3.2.9 *wire, telecommunications, n*—products containing less than six pairs.

ELECTRICAL TESTS OF INSULATION— IN-PROCESS

4. Scope

4.1 In-process electrical tests are used primarily as process control tools in an attempt to minimize the number and magnitude of problems detected at final test of completed cable.

5. Significance and Use

5.1 Electrical tests, properly interpreted, provide information with regard to the electrical properties of the insulation. The electrical test values give an indication as to how the

insulation will perform under conditions similar to those observed in the tests. Electrical tests may provide data for research and development, engineering design, quality control, and acceptance or rejection under specifications.

6. Spark Test

6.1 The spark test is intended to detect defects in the insulation of insulated wire conductors. Spark testers are commonly used to detect insulation defects (faults) at conductor insulating operations, at pair twisting operations, and (occasionally) at operations for assembly or subassembly of conductors. In selected instances, spark tests may be used to detect defects in the jackets of shielded wire and cable, and in such cases, spark testers appear on cable jacketing lines. The basic method calls for a voltage to be applied between a grounded conductor and an electrode that is in mechanical contact with the surface of the material being tested. The wire or cable under test usually moves continuously against the electrode. When the dielectric medium is faulty (for example, excessively thin or missing, as in a pin-hole or when mechanically damaged), the impressed voltage will produce an arc to the grounded conductor. This arcing or sparking will usually activate one or more indicators (such as, warning buzzers or lights, counters, etc.) and, when appropriately interlocked, may halt the production or movement of the item through the spark tester electrode. For telecommunications products, the number of faults is usually only counted while production continues. Jacket defects may be flagged when detected. Jacket defects and units of insulated wire containing an excessive number of faults may be repaired or disposed of.

6.2 **Warning**—*Lethal voltages may be present during this test. It is essential that the test apparatus, and all associated equipment that may be electrically connected to it, be properly designed and installed for safe operation. Solidly ground all electrically conductive parts that any person might come into contact with during the test. Provide means for use at the completion of any test to ground any parts which: were at high voltage during the test; may have acquired an induced charge during the test; may retain a charge even after disconnection of the voltage source. Thoroughly instruct all operators in the proper way to conduct tests safely. When making high voltage tests, particularly in compressed gas or in oil, the energy released at breakdown may be sufficient to result in fire, explosion, or rupture of the test chamber. Design test equipment, test chambers, and test specimens so as to minimize the possibility of personal injury.*

6.3 Unless otherwise limited by detailed specification requirements, spark testers used may generate either an ac or dc test voltage; if ac, various frequencies may be used. For safety to personnel, spark test equipment is usually current-limited to levels normally considered to be non-lethal. Unless otherwise specified, the test voltage level employed shall be at the discretion of the manufacturer.

6.4 Unless otherwise limited by detailed specification requirements, various types of electrodes may be used, at the discretion of the manufacturer. Bead chains, water, ionized air and spring rods are among electrode types that have been successfully employed. The length of the electrode is also variable; unless otherwise limited by detailed specification

³ Available from Global Engineering Documents, 15 Inverness Way East, Englewood, CO 80113-5776.

requirements, electrode size and length shall be such that the tester will operate successfully for any particular rate of travel of the product through the tester that is used. In spite of current limitations, electrodes are normally provided with grounded metallic screens or shields to guard against accidental personnel contact.

6.5 Both ends of the conductor of an insulated wire, or both ends of a metallic shield under a cable jacket are grounded, and then attached to the ground side of the tester. Attach the high voltage side of the tester to the sparker electrode. Set the test voltage at the level specified. Unless otherwise specified, energize the spark tester whenever the product to be tested is moving through the electrode. Take appropriate action (for example, flag defects, count defects, adjust the process, etc.) when and if defects are detected.

6.6 *Report:*

6.6.1 Report the following information recorded on suitable forms (that is, production reports):

6.6.1.1 Machine number and type (that is, extruder, twister, etc.),

6.6.1.2 Date of production test,

6.6.1.3 Insulation type (air core or filled core), conductor gage and footage,

6.6.1.4 Voltage level, and

6.6.1.5 Number of indicated faults.

6.7 *Precision and Bias*—The precision of this test has not been determined. No statement can be made about the bias of this spark test since the result merely states whether there is conformance to the criteria for success specified in the product specification.

7. Insulation Defect or Fault Rate—In-Process

7.1 For purposes of in-process control, it may be desirable to monitor and record in-process faults at a particular operation (such as, extruders, twisters, etc.) and relate the number of defects found to the quantity of product produced.

7.2 When appropriate and using records of the quantity of product produced versus the number of insulation defects counted, a fault rate may be established as a ratio as follows:

$$\text{Fault Rate} = \frac{N}{L} = \frac{1}{\bar{X}} \quad (1)$$

where:

N = the number of faults detected,

L = the length of the product over which the faults are detected, and

\bar{X} = the average length of the product per fault.

7.3 Fault rates may be determined for any particular time frame as desired; however, minimum industry practice is to keep fault rate records covering periods approximating 1 month, with cumulative records kept for 6-month periods (for example, for the first 6 months of the year, the fault rate was 1/40 000 ft, meaning 1 fault/40 000 conductor ft).

7.4 *Report*—Report in accordance with 6.6.

7.5 *Precision and Bias*—The precision of this test has not been determined. No statement can be made about the bias of this test for insulation defect or fault rate since the result merely states whether there is conformance to the criteria for success specified in the product specification.

8. DC Proof Test—In-Process

8.1 For purposes of in-process control, it may be desirable to dc proof test product at one or more stages of processing prior to the final test operation. Such testing is normally at the discretion of the manufacturer.

8.2 Conduct wire-to-wire dc proof tests in accordance with Section 37 following, at whatever stage of production may be appropriate and designated by the factory management.

8.3 *Report*—Report in accordance with Section 52 except that 52.1.5 does not apply.

8.4 *Precision and Bias*—The precision of this test has not been determined. No statement can be made about the bias of this dc proof test since the result merely states whether there is conformance to the criteria for success specified in the product specification.

ELECTRICAL TESTS OF COMPLETED WIRE AND CABLE

9. Scope

9.1 Electrical tests of completed wire and cable may include verification of some or all of the properties in accordance with Sections 11 through 51.

10. Significance and Use

10.1 Electrical tests, properly interpreted, provide information with regard to the electrical properties of the insulation or of the jacket, or both. The electrical test values give an indication as to how the wire or cable, or both, will perform under conditions similar to those observed in the tests. Electrical test may provide data for research and development, engineering design, quality control, and acceptance or rejection under specifications.

11. Conductor Continuity

11.1 Continuity of the conductors of a telecommunications wire and cable is a critical characteristic.

11.2 Unless otherwise specified or agreed upon, conductor continuity shall be verified using a dc potential of 100 V or less. Manual continuity checkers commonly take a form of a battery voltage source of 9 V, in series with a visible or audible indicator with hand-held test leads. Automatic test equipment, also available to test properly terminated wire and cable, normally provides an indication (lights or printout) when continuity does not exist.

11.3 Prepare each end of the wire or cable for test. This usually involves stripping some insulation from each conductor at each end and separating the conductors at one or both ends. When automatic test equipment is used, terminate the individual conductors at a test fixture (both ends are normally terminated since this automatic test is often performed in conjunction with other tests). When manual continuity checking is performed, it is usually suitable to connect all conductors to a common termination (for example, wrap stripped ends with a length of copper wire, immerse one end in an electrically conductive liquid, etc.) at one end of the wire or cable.

11.4 In succession, apply the voltage source to one end of each conductor. Use test equipment indicators to verify the continuous circuit paths or detect the discontinuities.

11.5 After defective conductors are repaired, continuity checks must be repeated.

11.6 *Report*—Report in accordance with Section 52.

11.7 *Precision and Bias*—The precision of this test has not been determined. No statement can be made about the bias of this test for conductor continuity since the result merely states whether there is conformance to the criteria for success specified in the product specification.

12. Continuity of Other Metallic Cable Elements

12.1 In addition to the metallic conductors intended for information transmission, telecommunications wire and cable may contain one or more additional metallic elements in the form of a shield, armor, or an internal shield or screen that separates a cable into compartments, etc. Depending upon the particular product design, these elements may or may not be in contact with each other (cross-continuity). The continuity of each of these elements is normally considered to be a critical parameter.

12.2 Unless otherwise specified or agreed upon, verify the individual continuity of each shield, armor, screen (internal shield), or other metallic cable element of the cable construction using a dc potential of 100 V or less, in accordance with Section 11. When metallic elements under test are insulated, the insulation is normally removed to the extent necessary for testing. If continuity between any of these metallic elements is required, it shall be verified; if such continuity is expected but not required, it may be verified at the discretion of the manufacturer. If continuity between any of these metallic elements is not permitted, verify isolation in accordance with Section 42.

12.3 *Report*—Report in accordance with Section 52.

12.4 *Precision and Bias*—The precision of this test has not been determined. No statement can be made about the bias of this test for continuity of other metallic cable elements since the result merely states whether there is conformance to the criteria for success specified in the product specification.

13. Conductor Resistance (CR)

13.1 The conductor resistance (CR) in telecommunications wire and cable is a key characteristic; however, conductor resistance is normally verified only on a quality assurance sampling basis for finished products. Complete shipping units (full reels or other) of wire or cable, or both (not specimen lengths) shall constitute the basic sample. When the selected sample reel is a cable containing a great many conductors, the conductors of the sample cable are also checked on a sampling basis (that is, sampling of the sample).

13.2 Unless otherwise specified or agreed upon, measure the dc conductor resistance (CR) at or corrected to 20°C (68°F). Temperature correction shall be performed as described in Test Method B 193. The dc resistance is considered to vary directly with cable length.

13.3 Conductor resistance measurements are commonly made using volt/ohm meters or Wheatstone bridges having an accuracy of ±0.5 %. Various types of automatic or semiautomatic equipment may also be used.

13.4 Follow the general procedures of 11.3 through 11.5 for end preparation followed by measurement using the voltage

supplied by the test instrument. Record instrument readings obtained for each tested conductor. Note that data for resistance unbalance testing (Section 15) is normally obtained during this procedure; consequently, care must usually be taken to record data separately in pair groupings. See Section 15 for details.

13.5 Upon completion of measurements, manipulate the recorded data as appropriate (for example, determine averages, adjust for temperature and length, etc.) and compare with the requirements of detailed specifications.

13.6 *Report*:

13.6.1 Report in accordance with Section 52 and include the following:

13.6.1.1 Minimum, maximum and average values, and

13.6.1.2 Ambient temperature.

13.7 *Precision and Bias*—The precision of this test has not been determined. No statement can be made about the bias of this test for conductor resistance since the result merely states whether there is conformance to the criteria for success specified in the product specification.

14. Resistance of Other Metallic Cable Elements

14.1 It is occasionally important to know the resistance of other metallic elements (most often shield resistance) within telecommunications wire and cable. When required, this information may be obtained following 13.2 through 13.4, measuring cable construction elements as appropriate.

14.2 *Report*—Report in accordance with Section 52 and include the ambient temperature.

14.3 *Precision and Bias*—The precision of this test has not been determined. No statement can be made about the bias of this test for resistance of other metallic cable elements since the result merely states whether there is conformance to the criteria for success specified in the product specification.

15. Conductor Resistance Unbalance (CRU of Pairs)

15.1 The difference in resistance between two conductors of any pair can be a key characteristic in telecommunications; however, Conductor Resistance Unbalance (CRU) is normally verified only on a quality assurance sampling basis for finished products.

15.2 The conductor resistance unbalance is usually determined at the same time that conductor resistance measurements are made; consequently, 13.2 through 13.5 apply and resistance data is recorded in pair groupings.

15.3 The absolute difference in resistance unbalance is calculated by subtracting the lesser resistance from the greater resistance. Absolute resistance unbalance is normally expressed in Ω/1000 ft or Ω/km. A more useful and generally used expression for resistance unbalance is percent resistance unbalance, where:

$$\text{CRU} = \frac{R_{\max} - R_{\min}}{R_{\min}} \cdot 100 \% \quad (2)$$

where:

CRU = the conductor resistance unbalance in %,

R_{\max} = the maximum conductor resistance of a conductor in a pair, and

R_{min} = the minimum conductor resistance of a conductor in a pair.

NOTE 1—Care should be taken to identify the method for determining conductor resistance unbalance. IEC 61156-1 defines conductor resistance unbalance as the ratio of the difference in resistance of two conductors to the sum of their resistances. Therefore, the IEC values are less than half of those defined in 15.3.

15.4 Telecommunications wire and cable users are generally interested in two resistance unbalance values; cable average and maximum individual pair unbalance. Cable average in absolute or percentage terms is determined by standard averaging techniques, while the maximum individual pair unbalance in absolute or percentage terms is determined by simple inspection of the data. Data values are then compared with detailed specification requirements to verify conformance.

15.5 *Report*—Report in accordance with Section 52 and include the average and maximum values.

15.6 *Precision and Bias*—The precision of this test has not been determined. No statement can be made about the bias of this test for conductor resistance unbalance (pairs) since the result merely states whether there is conformance to the criteria for success specified in the product specification.

16. Mutual Conductance

16.1 The mutual conductance of a pair in a wire or cable is proportional to the mutual capacitance, the average value of the effective dissipation factor of the insulating system, and the frequency. Although it is one of the primary transmission characteristics, mutual conductance is the least consistent; the conductance of an individual pair may vary as much as 10 to 15 % from the nominal values at carrier frequencies. The effect of conductance on the secondary parameters is negligible at voice frequency, and contributes less than 1 % to the secondary parameters at 1 MHz, so the inconsistency is of little consequence. Although conductance also varies with temperature, the correction is insignificant in comparison with other sources of variation, so it is usually neglected.

16.2 Because of the constraints mentioned in 16.1, mutual conductance is only measured rarely, and readings are usually taken on short specimen lengths (an exact 32-ft specimen is convenient). When an impedance bridge is used for measurements, conductance and capacitance may be read directly from the instrument balance settings. Various types of automatic or semiautomatic equipment may also be used.

16.3 Unless otherwise specified, obtain mutual conductance readings at $23 \pm 3^\circ\text{C}$ and a test frequency of 1000 ± 100 Hz. Measured values are normally converted to a standard length value (normally one mile or one km). For conductance in micro-Siemens per mile, the values would be:

$$G_o = \frac{G \times 5280}{L} \quad \mu\text{S} / \text{mile} \quad (3)$$

$$G_o = \frac{G \times 1000}{L} \quad \mu\text{S} / \text{km}$$

where:

G_o = mutual conductance, $\mu\text{S}/\text{mile}$ (km),
 G = conductance reading, μS , and
 L = specimen length, ft (m).

16.4 *Report*—Report in accordance with Section 52 and include the maximum value.

16.5 *Precision and Bias*—The precision of this test has not been determined. No statement can be made about the bias of this test for mutual conductance since the result merely states whether there is conformance to the criteria for success specified in the product specification.

17. Coaxial Capacitance (Capacitance to Water)

17.1 Coaxial capacitance for insulated wire is defined as the capacitance existing between the outer surface of the round metallic conductor and the outer surface of the insulating dielectric applied over that conductor.

NOTE 2—For a more general definition, refer to Test Methods D 150 or to Terminology D 1711.

17.2 In-process measurements of coaxial capacitance are made by passing the insulated conductor through a water bath while measurements are made between the grounded conductor and the water. Automatic feedback of data is then used to control the insulating equipment. Such measurements are generally not suitable for product acceptance.

17.3 For purposes of measuring coaxial capacitance in completed wire, a sample of insulated wire is immersed in a water bath and the direct capacitance is measured between the conductor and the water. Unless otherwise specified perform measurements at a water temperature of $20 \pm 2^\circ\text{C}$ and a test frequency of 1000 ± 100 Hz using capacitance or impedance bridges, capacitance meters, etc. Unless otherwise prohibited, other equipment yielding equivalent results may be used.

17.4 *Report*—Report in accordance with Section 52 and include the minimum, maximum and average values.

17.5 *Precision and Bias*—The precision of this test has not been determined. No statement can be made about the bias of this test for coaxial capacitance (capacitance to water) since the result merely states whether there is conformance to the criteria for success specified in the product specification.

18. Mutual Capacitance (CM)

18.1 Mutual capacitance (CM) is defined as the effective capacitance between the two wires of a pair. In a multi-pair cable, the mutual capacitance is defined as:

$$\text{CM} = C_{AB} + \frac{C_{AG} \cdot C_{BG}}{C_{AG} + C_{BG}} \quad \text{nF} / \text{cable length} \quad (4)$$

where:

CM = the mutual capacitance, and

C_{AB} , C_{AG} , and C_{BG} are as illustrated in Fig. 1.

18.2 Mutual capacitance is a critical characteristic in telecommunications wire and cable; consequently, unless otherwise specified or agreed upon between the producer and the user, each lot of product is checked to verify this parameter.

18.3 Before measuring, the cable to be tested must be prepared by removing the jacket(s) and shield or armor, when present, from both ends of the cable to expose approximately 2 ft (600 mm) of the cable core. Conductors at one end of the cable are then fanned out to ensure that no conductors are shorted or grounded. Insulation is then stripped for approximately 1 to 3 in. (25 to 75 mm) from the conductors at the other

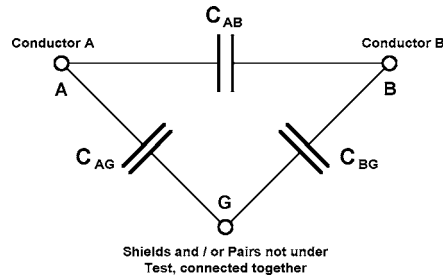

FIG. 1 Mutual Capacitance Relationships

end of the cable. All conductors are then shorted together and to ground to dissipate any static charge that may have accumulated.

18.4 Unless otherwise specified, mutual capacitance is understood to mean capacitance at a test frequency of 1000 ± 100 Hz, and this test frequency shall be used if measurement is made using a bridge technique. Other test methods yielding comparable results shall be considered as acceptable if not specifically prohibited.

18.5 Mutual capacitance readings are commonly made manually using impedance bridges or capacitance meters; various types of automatic or semiautomatic equipment may also be used.

18.6 Specification limits are generally placed on the cable average mutual capacitance and on the individual pair mutual capacitance. Limits for individual pairs can be verified only by making measurements of individual pairs, and such measurements are normally made for cables of 25 or fewer pairs; for larger cables, individual measurements are often made only on a quality assurance sampling basis. Cable averages can be obtained by averaging individual pair readings. Average mutual capacitance can also be measured by grouping a number of pairs together (electrical in parallel circuits), measuring the capacitance of the group and dividing the total capacitance by the number of pairs tested to obtain a grouped average. When grouped readings are made, no more than 25 pairs should be grouped for any one reading. Conversely, grouped readings should not be used for cables containing 25 or fewer pairs.

18.7 Unless otherwise specified, measure mutual capacitance at $23 \pm 3^\circ\text{C}$. Measured values are normally converted to a standard length value (normally 1 mile or 1 km). For mutual capacitance in nano-Farad/mile, the values would be:

$$C_o = \frac{C \times 5280}{L} \quad \text{nF / mile} \quad (5)$$

$$C_o = \frac{C \times 1000}{L} \quad \text{nF / km}$$

where:

- C_o = mutual capacitance, nF/mile (nF/km),
- C = mutual capacitance, measured, nF, and
- L = specimen length, ft (m).

NOTE 3—This method is applicable for lengths of 10 000 ft (3.05 km) or less. Special correction factors are required for longer lengths.

18.8 Report:

18.8.1 Report in accordance with Section 52 and include the following:

18.8.1.1 Minimum, maximum, and average values, and

18.8.1.2 Standard deviation.

18.9 *Precision and Bias*—The precision of this test has not been determined. No statement can be made about the bias of this test for mutual capacitance since the result merely states whether there is conformance to the criteria for success specified in the product specification.

19. Capacitance Deviation

19.1 The desired intent of most telecommunications cable specifications is to have an individual pair mutual capacitance and a reel average mutual capacitance as close to the specified nominal requirement as possible. It is also intended that differences between reels of cable of different wire gages and of different pair counts should be kept to a minimum. The capacitance deviation for any reel of cable is defined as the calculated root mean square deviation of the mutual capacitance of all the measured pairs of the reel of cable from the average mutual capacitance for that reel of cable.

19.2 Using the methods described in Section 18, measure the individual pair mutual capacitances. (Note that this method cannot be applied to grouped mutual capacitance readings.) Calculate the capacitance deviation from the measured data using the following equation:

$$D = \frac{\sigma}{\bar{x}} \times 100 \% \quad (6)$$

where:

D = % root mean square (rms) deviation from average,

$$\sigma = \sqrt{\frac{\sum x^2}{N} - \left(\frac{\sum x}{N}\right)^2}$$

$$\bar{x} = \frac{\sum x}{N}$$

x = individual mutual capacitance values (nF/mile, nF/kft, nF/km, etc.), and

\bar{x} = average mutual capacitance value (nF/mile, nF/kft, nF/km, etc.).

19.2.1 The calculated percentage deviation for any measured cable shall comply with the requirements of the product specification.

19.3 *Report*—Report in accordance with Section 52 and include the percent deviation.

19.4 *Precision and Bias*—The precision of this test has not been determined. No statement can be made about the bias of this test for capacitance deviation since the result merely states whether there is conformance to the criteria for success specified in the product specification.

20. Capacitance Difference (Filled Core only)

20.1 This test may be used to provide some assurance that a filled cable is adequately filled across the entire cross-section of the cable core. This test can be applied only to cables that are manufactured with a clearly discernible center layer of pairs.

20.2 Using the methods described in Sections 13 and 18, measure the conductor resistance and mutual capacitance of individual pairs selected at random, keeping separate records for pairs from the inner layer and for pairs from the outer layer. When measuring compartmental core cable, make measurements in each compartment separately. Unless otherwise permitted the number of inner and outer pair readings shall each be at least 5 % of the total pair count, or 25 readings, whichever is less.

20.3 Calculate the average conductor resistance and average mutual capacitance for the innermost pairs (center layer) and record as (R_1 and C_1 , respectively). Repeat this calculation for the outermost pairs and record as (R_o and C_o , respectively).

20.4 Calculate the percent difference, D , in the average mutual capacitance for the innermost and outermost pairs using the following equation:

$$D = \frac{C_o - C_1}{C_o} - \frac{R_o - R_1}{R_o} \cdot 100 \% \quad (7)$$

20.4.1 The calculated percentage difference for any measured cable shall comply with the requirements of the product specification.

20.5 *Report*—Report in accordance with Section 52.

20.6 *Precision and Bias*—The precision of this test has not been determined. No statement can be made about the bias of this test for capacitance difference since the result merely states whether there is conformance to the criteria for success specified in the product specification.

21. Capacitance Unbalance—Pair-to-Pair (CUPP)

21.1 The capacitances involved and the definition of capacitance unbalance pair-to-pair (CUPP) are illustrated in Fig. 2, where A and B represent the two conductors of a pair and C and D represent the two conductors of another pair.

21.1.1 The capacitances, namely C_{AC} , C_{AD} , C_{BC} and C_{BD} are the direct capacitances between conductors. Direct capacitance is defined in ANSI/IEEE Standard 100-1984.

21.1.2 The capacitances, C_{AG} , C_{BG} , C_{CG} and C_{DG} are the direct capacitances between wires A , B , C and D respectively, and all other conductors and shields in the cable that are connected to grounded.

21.2 Measure the capacitance unbalance, pair-to-pair at a test frequency of 1000 ± 100 Hz using a capacitance unbalance bridge. Various types of automatic and semiautomatic equipment may also be used.

21.3 In cables of 25 pairs or less and in each group of multi-group cables, the unbalances to be considered are all of the following:

21.3.1 Between pairs adjacent in a layer,

21.3.2 Between pairs in the center, when there are four pairs or less, and

21.3.3 Between pairs in adjacent layers, when the number of pairs in the inner (smaller) layer is six or less. Here, the center is counted as a layer.

21.4 If a capacitance bridge is not available, the direct capacitances (refer to 21.1) C_{AC} , C_{AD} , C_{BC} and C_{BD} can be measured using a voice-frequency capacitance bridge or comparable equipment. The capacitance unbalance, pair-to-pair (CUPP), can then be calculated using the following equation:

$$CUPP = (C_{AD} + C_{BC}) - (C_{AC} + C_{BD}) \quad \text{pF @ cable length} \quad (8)$$

21.5 Unless otherwise specified, correct the maximum, average, and root mean square unbalance values for each length other than 1000 ft (or 1000 m) to 1000 ft (or 1000 m) by dividing the value of unbalance for the length measured by the square root of the ratio of the length measured to 1000.

$$Y_1 = \frac{Y}{\sqrt{X/1000}} \quad \text{pF @ 1000 ft (1000 m)} \quad (9)$$

where:

Y_1 = unbalance corrected to 1000 ft (1000 m),

Y = unbalance of cable length, and

X = cable length, ft (m).

21.6 *Report*—Report in accordance with Section 52 and include the maximum, average, and root mean square values.

21.7 *Precision and Bias*—The precision of this test has not been determined. No statement can be made about the bias of this test for capacitance unbalance (pair-to-pair) since the result merely states whether there is conformance to the criteria for success specified in the product specification.

22. Capacitance Unbalance—Pair-to-Ground (CUPG)

22.1 The capacitances involved and the definition of capacitance unbalance, pair-to-ground (CUPG) are illustrated in Fig. 3, where A and B represent the two conductors of a pair. The capacitances, namely C_{AG} and C_{BG} are the direct capacitances between conductors A and B respectively and the shield. The

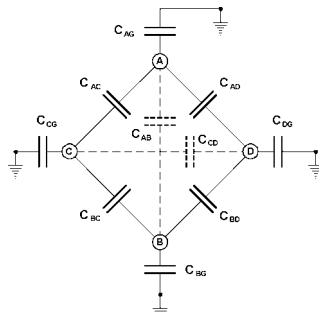
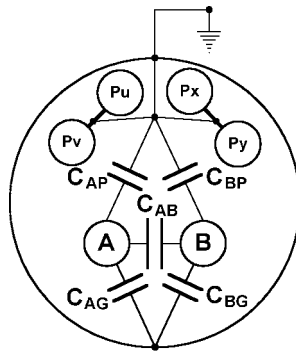

FIG. 2 Conductor Capacitances



All Pairs and / or Shields connected together and grounded

FIG. 3 Pair-to-Ground Capacitance Unbalance

capacitances C_{AP} and C_{BP} are the direct capacitances between conductors A and B respectively and all other pairs P , consisting of the conductors' u, v and x, y respectively.

22.2 Using a capacitance unbalance bridge, measure the pair-to-ground capacitance unbalance at a test frequency of 1000 ± 100 Hz. Various types of automatic and semiautomatic equipment may also be used.

22.3 If a capacitance unbalance bridge is not available, the direct capacitances (refer to 22.1) C_{AG}, C_{BG}, C_{AP} and C_{BP} can be measured using a voice-frequency capacitance bridge or comparable equipment. The capacitance unbalance, pair-to-ground, CUPG, can then be calculated using the following equation:

$$\text{CUPG} = (C_{AG} + C_{AP}) - (C_{BG} + C_{BP}) \quad \text{pF / cable length} \quad (10)$$

22.4 Unless otherwise specified correct the maximum and average capacitance unbalance values for each length, other than 1000 ft (or 1000 m), to 1000 ft (or 1000 m) by dividing the value of unbalance for the length measured by the ratio of the length measured to 1000.

$$Y_1 = \frac{Y}{X/1000} \quad (11)$$

where:

- Y_1 = unbalance corrected to 1000 ft (1000 m),
- Y = unbalance of cable length, and
- X = cable length, ft (m).

22.5 Report—Report in accordance with Section 52 and include the maximum and average values.

22.6 Precision and Bias—The precision of this test has not been determined. No statement can be made about the bias of this test for capacitance unbalance (pair-to-ground) since the result merely states whether there is conformance to the criteria for success specified in the product specification.

23. Capacitance Unbalance—Pair-to-Support Wire

23.1 This particular procedure is applied only to self-supported (that is, integral messenger wire) non-shielded telecommunications wire and cable.

23.2 Unbalances shall be measured as described in Section 22 except that the grounded support wire replaces the shield in

all measurements. The maximum allowable unbalances shall comply with the requirements of the product specification.

23.3 Report—Report in accordance with Section 52 and include the maximum value.

23.4 Precision and Bias—The precision of this test has not been determined. No statement can be made about the bias of this test for capacitance unbalance (pair-to-support wire) since the result merely states whether there is conformance to the criteria for success specified in the product specification.

24. Attenuation

24.1 Attenuation is a measure of the loss in signal strength over a length of wire or cable and is affected by the materials and geometry of the insulated conductors, the surrounding jacket material and/or eventual shield(s). Referring to Fig. 5, attenuation shall be defined as:

$$\alpha_i = \frac{1}{L_o} \cdot \left| 20 \cdot \log_{10} \frac{V_{iN}}{V_{iF}} \right| \quad \text{dB / length unit} \quad (12)$$

where:

- L_o = the measured length of the cable in length units, and
- α_i = the attenuation of the pair i .

24.2 Cable ends shall be prepared as described in 25.2.

24.3 The equipment used for measuring attenuation, unless otherwise specified, shall be (a) balanced to ground or (b) a network analyzer with an S-parameter test set in conjunction with balance to unbalanced impedance matching transformers (baluns). In the case (a) the test equipment shall have a nominal input and output impedance corresponding to the nominal characteristic impedance $\pm 1\%$ of the pairs under test. The input power to the pair under test shall be approximately 10 dBm. The circuit of Fig. 5, or equal, shall be used.

24.4 Unless otherwise specified, measure attenuation at or corrected to 20°C (68°F). Temperature corrections can be made using the following equations, taking into account the copper conductor resistance increase with temperature:

$$\alpha_{20} = \frac{\alpha_T}{[1 + 0.0022 \cdot (T - 20)]} = \frac{\alpha_T}{\text{TCF in } ^\circ\text{C}} \quad \text{dB / length unit} \quad (13)$$

$$\alpha_T = \alpha_{20} \cdot \text{TCF in } ^\circ\text{C} \quad \text{dB / length unit}$$

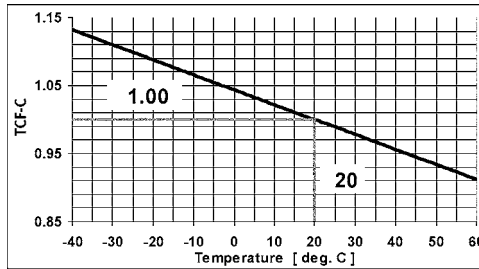

(a) Attenuation temperature correction factor for temperatures given in °C

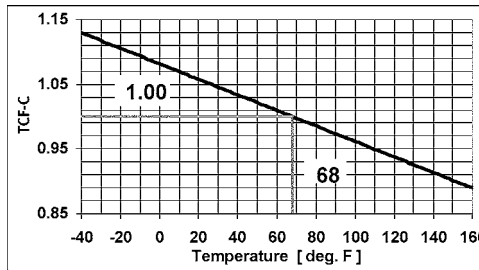

(b) Attenuation temperature correction factor for temperatures given in °F

FIG. 4 Attenuation Temperature Correction Factor

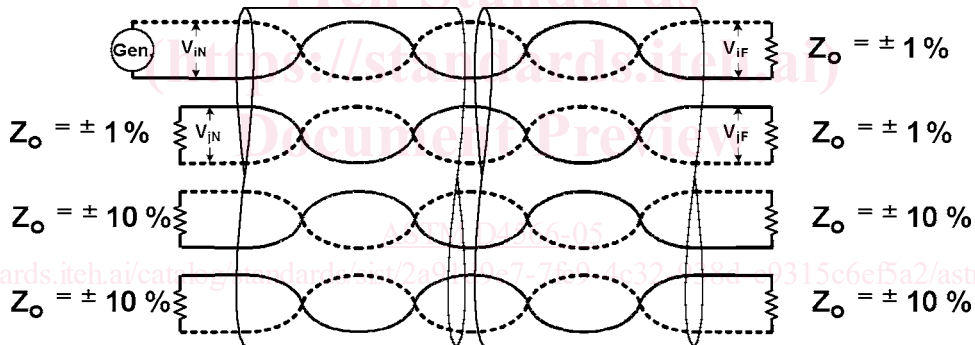

NOTE 1—Source Impedance = $Z_o \pm 1\%$.
 NOTE 2—Pairs not under test terminated with resistors = $Z_o \pm 10\%$.
 NOTE 3—Terminating resistors Z_o shall be non-inductive.

FIG. 5 Test Circuit for Crosstalk Measurements

where:
 α_{20} = the attenuation corrected to 20°C,
 α_T = the measured attenuation at temperature T ,
 T = the measured temperature, °C, and
 TCF in °C = the temperature correction factor at temperature T .

$$\alpha_{68} = \frac{\alpha_T}{[1 + 0.0022 \cdot (T - 68)]} = \frac{\alpha_T}{\text{TCF in } ^\circ\text{F}} \quad \text{dB / length unit} \quad (14)$$

$$\alpha_T = \alpha_{68} \cdot \text{TCF in } ^\circ\text{F} \quad \text{dB / length unit}$$

where:
 α_{68} = the attenuation corrected to 68°F,

α_T = the measured attenuation at temperature T ,
 T = the measured temperature, °F, and
 TCF in °F = the temperature correction factor at temperature T .

NOTE 4—When the temperature coefficient of the attenuation increase is higher than the increase due to resistance increase of the copper conductors alone, the coefficient has to be determined, see Section 29.

24.5 Alternately, the information given in Fig. 4(a) and Fig. 4(b) may be used for performing temperature corrections. Measured values are normally converted to a standard length value (normally 1 mile, 1000 ft, or 1 km). Attenuation is

considered to vary directly with length. The correction factors are based on Eq 13 and 14.

24.6 Upon completion of measurements, mathematically manipulate the recorded data as appropriate (for example, determine averages, adjust for temperature and length, etc.) and compare with the requirements of detailed specifications.

24.7 *Report:*

24.7.1 Report in accordance with Section 52 and include the following:

24.7.1.1 Minimum, maximum, and average values, and

24.7.1.2 Ambient temperature.

24.8 *Precision and Bias*—The precision of this test has not been determined. No statement can be made about the bias of this test for attenuation since the result merely states whether there is conformance to the criteria for success specified in the product specification.

25. Crosstalk Loss—Near End

25.1 Near-end crosstalk loss (NEXT) is usually defined and measured as an input-to-output crosstalk coupling between two pairs on the same end of the cable. Hence, NEXT is the logarithmic ratio of the input power of the disturbing pair i to the output power of the disturbed pair j on the same end of the cable. Referencing Fig. 5, the NEXT shall be defined as:

$$\text{NEXT}_{ij} = \left| 20 \cdot \log_{10} \frac{V_{iN}}{V_{jN}} \right| \quad \text{dB} \quad (15)$$

where:

NEXT_{ij} = the NEXT measured, dB,

i = the disturbing pair,

j = the disturbed pair,

V_{iN} = the input voltage to the disturbing pair at the near end, and

V_{jN} = the output voltage of the disturbed pair at the near end.

25.1.1 To correct crosstalk values to the nominal characteristic impedance, when the terminating and characteristic impedance are different, Eq 15 is changed as follows:

$$\text{NEXT}_{ij} = \left| 20 \cdot \log_{10} \frac{V_{iN}}{V_{jN}} \right| + 20 \cdot \log_{10} \frac{4Z_o \cdot Z}{(Z_o + Z)^2} \quad \text{dB} \quad (16)$$

where:

Z_o = nominal characteristic impedance of cable, and

Z = terminating impedance at the far end of both pairs.

25.2 Cable ends shall be prepared for test as described in 18.3 for low frequency cables. For cables intended to be used at frequencies beyond 2 MHz, the cable ends shall be kept to the minimum length that will permit a connection to the test equipment.

25.3 The equipment used for measuring crosstalk, unless otherwise specified, shall be (a) balanced to ground or (b) a network analyzer (NWA) with an S -parameter test set in conjunction with balance to unbalanced impedance matching transformers (baluns). The pairs under test shall be terminated in their nominal characteristic impedance $\pm 1\%$. Pairs not under test shall be terminated at both ends in their nominal characteristic impedance $\pm 10\%$. The input power to the disturbing pair shall be approximately 10 dBm. The circuit of Fig. 5, or equal, shall be used. If crosstalk values are

impedance-corrected to the nominal characteristic impedance as outlined in 25.1.1, the pairs under test may be terminated in their nominal characteristic impedance $\pm 25\%$. However, in case of conflict, data derived with the pairs terminated in their nominal characteristic impedance $\pm 1\%$ shall be used.

25.3.1 For low frequency cables and discrete frequency measurements, the following shortcut may be used. For accurate readings, each pair must be terminated; however, if readings are taken on a sampling of specific pairs, the pairs not under test usually can be left unterminated, since any error introduced by this shortcut will be minor.

NOTE 5—This is not necessarily true in the higher frequency ranges with swept frequency measurements.

25.4 Measure the NEXT between pairs, as required by the detailed product specification using the choice of equipment indicated in 25.3. Other types of automatic or semiautomatic equipment are acceptable.

25.5 For low frequency cables, the measured values are normally corrected to a standard length value (normally 1000 ft or 1000 m). Length correction of measured values is not required if lengths of 1000 ft (305 m) or more are used. If lengths less than 1000 ft (305 m) are measured, correct the reading to 1000 ft (305 m) by using the following equation:

$$\text{NEXT}_{ijLx} = \text{NEXT}_{ijLo} - 10 \cdot \log_{10} \frac{1 - e^{-4\alpha L_x}}{1 - e^{-4\alpha L_o}} \quad \text{dB} \quad (17)$$

where:

i = the disturbing pair,

j = the disturbed pair,

α = average attenuation of disturbing and disturbed pair Neper/unit length,

L_o = the measured cable length, ft (m),

L_x = the reference cable length, 1000 ft (305 m), and

$e = 2.71828$.

NOTE 6—This length correction is based upon the assumption of a strict length correlation of the crosstalk. This may be assumed only for large pair count cables on a statistical basis.

25.6 If the detailed product specification requires the near end crosstalk to be reported as power sum (P.S.), the P.S. NEXT can be calculated from readings obtained in 25.4 as follows:

$$\text{P.S. NEXT}_j = \left| 10 \cdot \log_{10} \sum_{\substack{i=1 \\ i \neq j}}^{i=n} 10^{\frac{-\text{NEXT}_i}{10}} \right| \quad \text{dB} \quad (18)$$

where:

i = the disturbing pair,

j = the disturbed pair, and

n = number of pairs.

25.7 *Report*—Report in accordance with Section 52 and include the following. The report differentiates between discrete frequency measurements at specified frequencies and swept frequency measurements with a dense frequency distribution at measurement points.

25.7.1 Measurements at specified frequencies:

25.7.1.1 Minimum and average values, and

25.7.1.2 Power sum near end crosstalk (if applicable).