**Light conveyor belts — Determination of
the coefficient of friction**

*Courroies transporteuses légères — Détermination du coefficient de
frottement*

iTeh STANDARD PREVIEW
(standards.iteh.ai)

ISO 21182:2005

<https://standards.iteh.ai/catalog/standards/sist/0f590b7c-5ea9-4b79-84e2-1b38dff63984/iso-21182-2005>



PDF disclaimer

This PDF file may contain embedded typefaces. In accordance with Adobe's licensing policy, this file may be printed or viewed but shall not be edited unless the typefaces which are embedded are licensed to and installed on the computer performing the editing. In downloading this file, parties accept therein the responsibility of not infringing Adobe's licensing policy. The ISO Central Secretariat accepts no liability in this area.

Adobe is a trademark of Adobe Systems Incorporated.

Details of the software products used to create this PDF file can be found in the General Info relative to the file; the PDF-creation parameters were optimized for printing. Every care has been taken to ensure that the file is suitable for use by ISO member bodies. In the unlikely event that a problem relating to it is found, please inform the Central Secretariat at the address given below.

iTeh STANDARD PREVIEW
(standards.iteh.ai)

ISO 21182:2005

<https://standards.iteh.ai/catalog/standards/sist/0f590b7c-5ea9-4b79-84e2-1b38dff63984/iso-21182-2005>

© ISO 2005

All rights reserved. Unless otherwise specified, no part of this publication may be reproduced or utilized in any form or by any means, electronic or mechanical, including photocopying and microfilm, without permission in writing from either ISO at the address below or ISO's member body in the country of the requester.

ISO copyright office
Case postale 56 • CH-1211 Geneva 20
Tel. + 41 22 749 01 11
Fax + 41 22 749 09 47
E-mail copyright@iso.org
Web www.iso.org

Published in Switzerland

Foreword

ISO (the International Organization for Standardization) is a worldwide federation of national standards bodies (ISO member bodies). The work of preparing International Standards is normally carried out through ISO technical committees. Each member body interested in a subject for which a technical committee has been established has the right to be represented on that committee. International organizations, governmental and non-governmental, in liaison with ISO, also take part in the work. ISO collaborates closely with the International Electrotechnical Commission (IEC) on all matters of electrotechnical standardization.

International Standards are drafted in accordance with the rules given in the ISO/IEC Directives, Part 2.

The main task of technical committees is to prepare International Standards. Draft International Standards adopted by the technical committees are circulated to the member bodies for voting. Publication as an International Standard requires approval by at least 75 % of the member bodies casting a vote.

Attention is drawn to the possibility that some of the elements of this document may be the subject of patent rights. ISO shall not be held responsible for identifying any or all such patent rights.

ISO 21182 was prepared by Technical Committee ISO/TC 41, *Pulleys and belts (including veebelts)*, Subcommittee SC 3, *Conveyor belts*.

This International Standard is based on EN 1724:1998, prepared by CEN/TC 188.

iTeh STANDARD PREVIEW
(standards.iteh.ai)

ISO 21182:2005
<https://standards.iteh.ai/catalog/standards/sist/0f590b7c-5ea9-4b79-84e2-1b38dff63984/iso-21182-2005>

Introduction

The coefficient of friction of light conveyor belts has to be seen from two different aspects relevant to the choice of the reference material. One aspect is the friction of the underside of the belt. In practice this is not critical because it is low. Regardless of whether a table of steel or of wood is used, the coefficient of friction is within the range from 0,2 to 0,3 in most cases.

Contrary to this, the top face covers show values over an extended range dependent on their actual function. To achieve this function the material itself can be modified as well as the surface pattern but the test procedure is the same in every case. So it becomes clear that the chosen steel panel represents a compromise. Its main properties are reproducibility of the surface finish and uncritical friction behaviour against any kind of belt cover.

This International Standard allows comparison of all kinds of conveyor belt to obtain reliable results as a reference. This may be helpful to buyers who need guidance in choosing the right belt for their particular application.

The tests in accordance with this International Standard are limited to dynamic coefficients of friction (μ_D) up to 1,0 and static coefficients of friction (μ_S) up to 1,5. Higher values can show a mixture of friction, adhesion, deformation and other effects occurring, especially where the surface texture is coarse and is therefore unsuitable for this test.

iTeh STANDARD PREVIEW

The method using the standardized metallic test panel is intended especially to compare the coefficients of friction of different light conveyor belts. The values received under practice conditions always depend on the frictional partners.

ISO 21182:2005

To determine these effects, it is possible to choose a different frictional partner instead of the panel if required. This is mentioned in the test report.

<https://standards.itih.ai/catalog/standards/sist/0590b7c-5ea9-4b70-84e2-1b38dff63984/iso-21182-2005>

Light conveyor belts — Determination of the coefficient of friction

1 Scope

This International Standard specifies test methods for determining the dynamic and static coefficients of friction for light conveyor belts according to ISO 21183-1.

2 Normative references

The following referenced documents are indispensable for the application of this document. For dated references, only the edition cited applies. For undated references, the latest edition of the referenced document (including any amendments) applies.

ISO 3574:1999, *Cold-reduced carbon steel sheet of commercial and drawing qualities*

ISO 4287, *Geometrical Product Specification (GPS) — Surface texture: Profile method — Terms, definitions and surface texture parameters*

ISO 7500-1:2004, *Metallic materials — Verification of static uniaxial testing machines — Part 1: Tension/compression testing machines — Verification and calibration of the force-measuring system*

ISO 18573:2003, *Conveyor belts — Test atmospheres and conditioning periods*

ISO 21183-1, *Light conveyor belts — Part 1: Principal characteristics and applications*

3 Terms and definitions

For the purposes of this document, the following terms and definitions apply.

3.1 dynamic coefficient of friction

μ_D
coefficient expressed by

$$\mu_D = \frac{F_D}{F_N}$$

where

F_D is the dynamic frictional force, sliding friction,

F_N is the normal force

3.2
static coefficient of friction

μ_S
coefficient expressed by

$$\mu_S = \frac{F_S}{F_N}$$

where

F_S is the static frictional force, “stiction” (break-away force),

F_N is the normal force

4 Principle

4.1 Dynamic coefficient of friction

A test piece cut from the full thickness of the conveyor belt in the longitudinal or transverse direction is clamped to a table. A metallic test panel subjected to a given normal force is pulled over the test piece at a defined speed. The μ_D value is then determined by calculation, using the dynamic frictional force (F_D) and the normal force (F_N).

iTeh STANDARD PREVIEW
(standards.iteh.ai)

4.2 Static coefficient of friction

A metallic test panel is subjected to a normal force as in 4.1. Additionally, a pulling force is exerted on the test panel, generated by a pulling mechanism moving at a defined speed. The μ_S value is determined by calculation, using the static frictional force (F_S) and the normal force (F_N).

5 Apparatus (see Figure 1)

5.1 Testing table, onto which the test piece shall be clamped.

5.2 Metallic test panel, see Figure 2, having the following dimensions:

- thickness, 0,8 mm;
- width, (76 ± 0,5) mm;
- length, 152 mm;
- testing area, (76 ± 0,5) mm × (131,5 ± 0,5) mm = (100 ± 1) cm².

The test panel shall be made of steel, type CR1 according to ISO 3574:1999, with a hardness of between HRB 60 and HRB 70, with a milled surface and surface roughness, R_a , 0,9 µm to 1,3 µm in accordance with ISO 4287.

Because the surface can change due to the abrasion of the test piece, the metallic test panel shall be replaced after a maximum of 50 applications, but after one day of use at the latest.

Because the test panel is not stainless it shall be kept in its original pack in a dry place until first used. The personnel handling the panel shall wear clean cotton gloves and touch the panel only at the edges.

5.3 Weight, generating a normal force of $50 \text{ N} \pm 1 \text{ N}$ together with the metallic test panel. The weight shall be made of steel having a density of $7,85 \text{ g/cm}^3$ and have the following dimensions:

- length, $(120 \pm 0,2) \text{ mm}$;
- width, $(75 \pm 0,2) \text{ mm}$;
- height, $(71 \pm 0,2) \text{ mm}$.

5.4 Device for the measurement of the frictional force

5.4.1 Load cell, with a range up to 100 N.

The force measuring system shall be in accordance with ISO 7500-1:2004, Class of machine 3 or better (e.g. Class of machine 2).

5.4.2 Recording instrument for recording the signal of the load cell

5.5 Pulling mechanism, for example, a tensile testing machine, to produce a uniform relative motion between test piece and metallic test panel.

5.6 Deflection roller, having a diameter of 40 mm to 50 mm and ball bearings to ensure smooth rotation.

5.7 Pulling cable, parallel to the sliding surface and with a low elasticity, e.g. steel cable with a diameter of approximately 1 mm.

iTeh STANDARD PREVIEW
(standards.iteh.ai)

6 Test piece

6.1 Test piece material [ISO 21182:2005](https://standards.iteh.ai/catalog/standards/sist/0f590b7c-5ea9-4b79-84e2-1b38dff63984/iso-21182-2005)

Test piece material shall be new, unused ("virgin"), but shall not be tested sooner than five days after manufacture. It shall be free from contamination and superficial damage.

6.2 Number and dimensions of test pieces

Three test pieces shall be cut from the full thickness of the conveyor belt in the longitudinal and/or transverse direction: one from the middle of the belt; the others 100 mm from each of the belt edges.

If both surfaces of the belt are to be tested, additional test pieces shall be taken accordingly.

The test pieces shall measure 600 mm long \times 100 mm wide.

Each test piece shall be used only once.

6.3 Conditioning

Before testing, condition the test pieces in accordance with ISO 18573:2003, Atmosphere B, for at least 24 h.

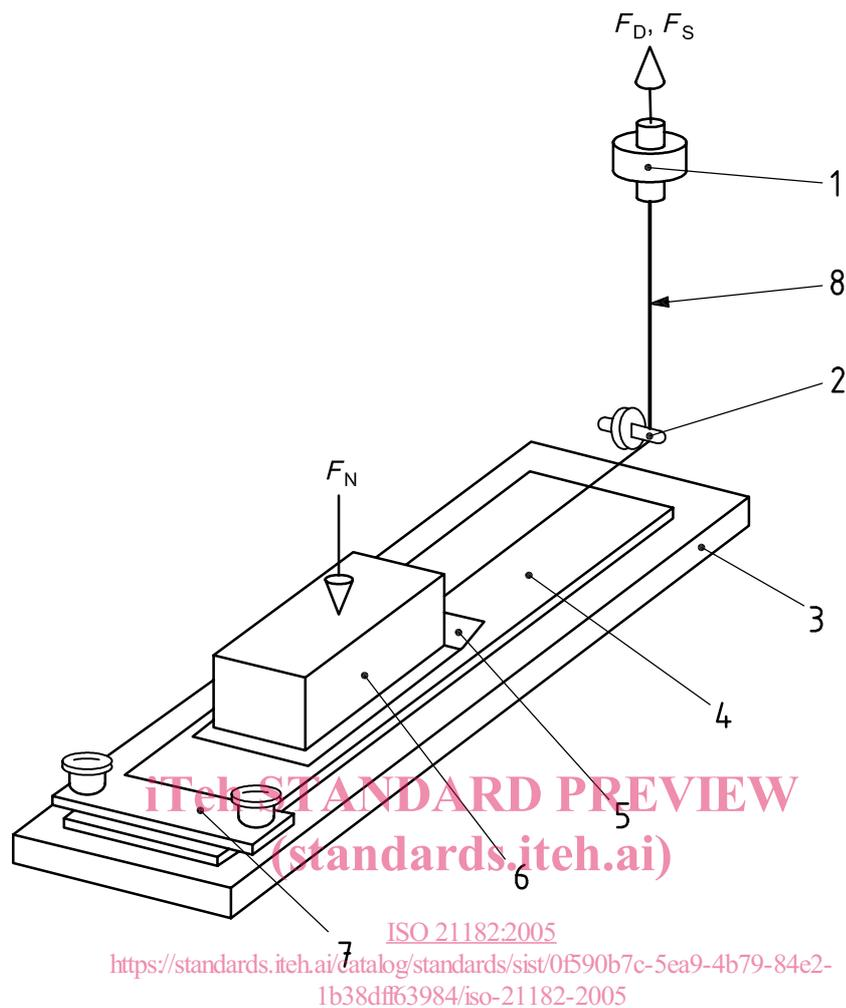

Key

- 1 load cell
- 2 deflection roller
- 3 test piece table
- 4 test piece
- 5 metallic test panel
- 6 weight
- 7 clamp
- 8 pulling cable

Figure 1 — Friction testing apparatus

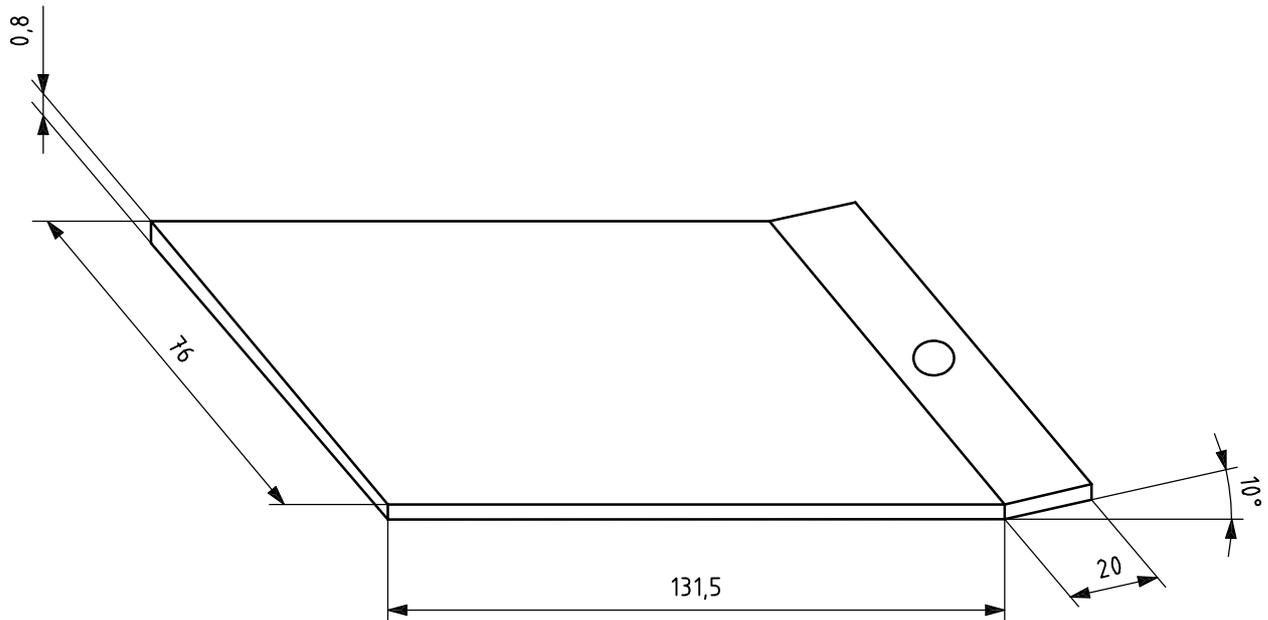

Figure 2 — Metallic test panel
 iTeh STANDARD PREVIEW
 (standards.iteh.ai)

7 Procedure

ISO 21182:2005

<https://standards.iteh.ai/catalog/standards/sist/0f590b7c-5ea9-4b79-84e2->

Measure the temperature and relative humidity in the test room.

Adjust the testing table (5.1) to the horizontal position in the longitudinal and transverse directions.

Clamp the test piece to the table.

Visually inspect the metallic test panel (5.2) to check that it is free from rust.

Clean the metallic test panel by using pure acetone and a soft tissue which is not dissolved by the acetone and does not leave any residue on the panel. Let the acetone evaporate and polish the panel afterwards with a new, dry tissue. Then place the panel on the test piece.

Connect the pulling cable (5.7) to the panel and place the weight (5.3) on the panel.

If measuring the dynamic coefficient of friction, μ_D , adjust the speed of the pulling mechanism to $(1\ 000 \pm 20)$ mm/min, except that if the maximum speed of the machine is less than 1 000 mm/min, the speed of the pulling may be reduced, but not to below (500 ± 20) mm/min. Ensure that the path of motion is 300 mm.

If measuring the static coefficient of friction, μ_S , adjust the speed of the pulling mechanism to (100 ± 10) mm/min. Stop the measurement as soon as the test panel begins to move.