



Designation: C 1433 – 04^{e1}

Standard Specification for Precast Reinforced Concrete Box Sections for Culverts, Storm Drains, and Sewers¹

This standard is issued under the fixed designation C 1433; the number immediately following the designation indicates the year of original adoption or, in the case of revision, the year of last revision. A number in parentheses indicates the year of last reapproval. A superscript epsilon (ϵ) indicates an editorial change since the last revision or reapproval.

^{e1} NOTE—Editorial changes were made throughout in April 2005.

1. Scope

1.1 This specification covers single-cell precast reinforced concrete box sections intended to be used for the construction of culverts and for the conveyance of storm water industrial wastes and sewage.

1.2 This specification is the companion to SI Specification C 1433M; therefore, no SI equivalents are shown in this specification.

NOTE 1—This specification is primarily a manufacturing and purchasing specification. However, standard designs are included and the criteria used to develop these designs are given in **Appendix X1**. The successful performance of this product depends upon the proper selection of the box section, bedding, backfill, and care that the installation conforms to the construction specifications. The purchaser of the precast reinforced concrete box sections specified herein is cautioned that proper correlation of the loading conditions and the field requirements with the box section specified, and provision for inspection at the construction site, are required.

2. Referenced Documents

2.1 *ASTM Standards*:²

- A 82 Specification for Steel Wire, Plain, for Concrete Reinforcement
- A 185 Specification for Steel Welded Wire Reinforcement, Plain, for Concrete
- A 496 Specification for Steel Wire, Deformed, for Concrete Reinforcement
- A 497 Specification for Steel Welded Wire Reinforcement, Deformed, for Concrete

- A 615/A 615M Specification for Deformed and Plain Billet-Steel Bars for Concrete Reinforcement
 - C 31/C 31M Practice for Making and Curing Concrete Test Specimens in the Field
 - C 33 Specification for Concrete Aggregates
 - C 39 Test Method for Compressive Strength of Cylindrical Concrete Specimens
 - C 150 Specification for Portland Cement
 - C 309 Specification for Liquid Membrane-Forming Compounds for Curing Concrete
 - C 497 Test Methods for Concrete Pipe, Manhole Sections, or Tile
 - C 595 Specification for Blended Hydraulic Cements
 - C 618 Specification for Coal Fly Ash and Raw or Calcined Natural Pozzolan for Use as a Mineral Admixture in Concrete
 - C 822 Terminology Relating to Concrete Pipe and Related Products
 - C 989 Specification for Ground Granulated Blast-Furnace Slag for Use in Concrete and Mortars
 - C 1116 Specification for Fiber-Reinforced Concrete and Shotcrete
- 2.2 *AASHTO Standard*:³
Standard Specifications for Highway Bridges

3. Terminology

3.1 *Definitions*—For definitions of terms relating to concrete pipe, see Terminology C 822.

4. Types

4.1 Precast reinforced concrete box sections manufactured in accordance with this specification shall be one of two types identified in **Table 1** and **Table 2**, and shall be designated by type, span, rise, and design earth cover.

¹ This specification is under the jurisdiction of ASTM Committee C13 on Concrete Pipe and is the direct responsibility of Subcommittee C13.07 on Acceptance Specifications and Precast Concrete Box Sections.

Current edition approved Oct. 1, 2004. Published November 2004. Originally approved in 1999. Last previous edition approved in 2004 as C 1433–04.

² For referenced ASTM standards, visit the ASTM website, www.astm.org, or contact ASTM Customer Service at service@astm.org. For *Annual Book of ASTM Standards* volume information, refer to the standard's Document Summary page on the ASTM website.

³ Available from American Association of State Highway and Transportation Officials (AASHTO), 444 N. Capitol St., NW, Suite 249, Washington, DC 20001.

TABLE 1 Design Requirements for Precast Concrete Box Sections Under Earth Dead and HS20 Live Load Conditions

NOTE 1—Design earth covers and reinforcement areas are based on the weight of a column of earth over the width of the box section as defined in Appendix X1.

NOTE 2—Concrete design strength 5000 psi.

NOTE 3—The design earth cover indicated is the height of fill above the top of the box section. Design requirements are based on the material and soil properties, loading data, and typical section as included in Appendix X1. For alternative or special designs, see 7.2.

NOTE 4—Design steel area in square inches per linear foot of box section at those locations which are indicated on the typical section included in Fig. 1.

NOTE 5—The top section designation, for example, 3 ft by 2 ft by 4 in. indicates (interior horizontal span in feet) by (interior vertical rise in feet) by (wall and slab thickness in inches).

NOTE 6—In accordance with the acceptance criteria in 7.2, the manufacturer may interpolate the steel area requirements for fill heights between noted increments or may submit independent designs.

3 ft by 2 ft by 4 in.															
Span ft	Rise ft	Top in.	Bottom in.	Side in.	Haunch in.	Depth ft	Circumferential Reinforcement Areas, in. ² /ft								"M," in.
							A _{s1}	A _{s2}	A _{s3}	A _{s4}	A _{s5}	A _{s6}	A _{s7}	A _{s8}	
3	2	7	6	4	4	0<2	0.17	0.38	0.21	0.10	0.19	0.17	0.17	0.14	
3	2	4	4	4	4	2<3	0.13	0.21	0.21	0.10					31
3	2	4	4	4	4	3-5	0.10	0.10	0.10	0.10					31
3	2	4	4	4	4	10	0.10	0.10	0.10	0.10					31
3	2	4	4	4	4	15	0.10	0.14	0.14	0.10					31
3	2	4	4	4	4	20	0.11	0.18	0.19	0.10					31
3	2	4	4	4	4	25	0.14	0.23	0.23	0.10					31
3	2	4	4	4	4	30	0.17	0.27	0.27	0.10					31
3	2	4	4	4	4	35	0.20	0.31	0.31	0.10					31
3 ft by 3 ft by 4 in.															
Span ft	Rise ft	Top in.	Bottom in.	Side in.	Haunch in.	Depth ft	Circumferential Reinforcement Areas, in. ² /ft								"M," in.
							A _{s1}	A _{s2}	A _{s3}	A _{s4}	A _{s5}	A _{s6}	A _{s7}	A _{s8}	
3	3	7	6	4	4	0<2	0.17	0.40	0.23	0.10	0.20	0.17	0.17	0.14	
3	3	4	4	4	4	2<3	0.10	0.25	0.25	0.10					31
3	3	4	4	4	4	3-5	0.10	0.10	0.11	0.10					31
3	3	4	4	4	4	10	0.10	0.11	0.11	0.10					31
3	3	4	4	4	4	15	0.10	0.15	0.16	0.10					31
3	3	4	4	4	4	20	0.10	0.20	0.20	0.10					31
3	3	4	4	4	4	25	0.10	0.24	0.25	0.10					31
3	3	4	4	4	4	30	0.12	0.29	0.29	0.10					31
3	3	4	4	4	4	35	0.14	0.33	0.34	0.10					31
4 ft by 2 ft by 5 in.															
Span ft	Rise ft	Top in.	Bottom in.	Side in.	Haunch in.	Depth ft	Circumferential Reinforcement Areas, in. ² /ft								"M," in.
							A _{s1}	A _{s2}	A _{s3}	A _{s4}	A _{s5}	A _{s6}	A _{s7}	A _{s8}	
4	2	7.5	6	5	5	0<2	0.18	0.40	0.20	0.12	0.20	0.18	0.18	0.14	
4	2	5	5	5	5	2<3	0.21	0.23	0.20	0.12					38
4	2	5	5	5	5	3-5	0.12	0.12	0.12	0.12					38
4	2	5	5	5	5	10	0.12	0.12	0.13	0.12					38
4	2	5	5	5	5	15	0.14	0.17	0.18	0.12					38
4	2	5	5	5	5	20	0.19	0.23	0.23	0.12					38
4	2	5	5	5	5	25	0.23	0.28	0.28	0.12					38
4	2	5	5	5	5	30	0.28	0.33	0.33	0.12					38
4	2	5	5	5	5	35	0.33	0.38	0.39	0.12					38
4 ft by 3 ft by 5 in.															
Span ft	Rise ft	Top in.	Bottom in.	Side in.	Haunch in.	Depth ft	Circumferential Reinforcement Areas, in. ² /ft								"M," in.
							A _{s1}	A _{s2}	A _{s3}	A _{s4}	A _{s5}	A _{s6}	A _{s7}	A _{s8}	
4	3	7.5	6	5	5	0<2	0.18	0.45	0.23	0.12	0.22	0.18	0.18	0.14	
4	3	5	5	5	5	2<3	0.16	0.28	0.25	0.12					38
4	3	5	5	5	5	3-5	0.12	0.12	0.13	0.12					38
4	3	5	5	5	5	10	0.12	0.14	0.15	0.12					38
4	3	5	5	5	5	15	0.12	0.20	0.20	0.12					38
4	3	5	5	5	5	20	0.14	0.26	0.26	0.12					38
4	3	5	5	5	5	25	0.17	0.32	0.32	0.12					38
4	3	5	5	5	5	30	0.21	0.38	0.38	0.12					38
4	3	5	5	5	5	35	0.25	0.44	0.44	0.12					38

TABLE 1 *Continued*

4 ft by 4 ft by 5 in.															
Span ft	Rise ft	Top in.	Bottom in.	Side in.	Haunch in.	Depth ft	Circumferential Reinforcement Areas, in. ² /ft								"M," in.
							A _{s1}	A _{s2}	A _{s3}	A _{s4}	A _{s5}	A _{s6}	A _{s7}	A _{s8}	
4	4	7.5	6	5	5	0<2	0.18	0.47	0.25	0.12	0.23	0.18	0.18	0.14	
4	4	5	5	5	5	2<3	0.13	0.31	0.28	0.12					38
4	4	5	5	5	5	3-5	0.12	0.14	0.15	0.12					38
4	4	5	5	5	5	10	0.12	0.15	0.16	0.12					38
4	4	5	5	5	5	15	0.12	0.21	0.22	0.12					38
4	4	5	5	5	5	20	0.12	0.27	0.28	0.12					38
4	4	5	5	5	5	25	0.14	0.33	0.34	0.12					38
4	4	5	5	5	5	30	0.17	0.39	0.40	0.12					38
4	4	5	5	5	5	35	0.20	0.45	0.46	0.12					38
5 ft by 3 ft by 6 in.															
Span ft	Rise ft	Top in.	Bottom in.	Side in.	Haunch in.	Depth ft	Circumferential Reinforcement Areas, in. ² /ft								"M," in.
							A _{s1}	A _{s2}	A _{s3}	A _{s4}	A _{s5}	A _{s6}	A _{s7}	A _{s8}	
5	3	8	7	6	6	0<2	0.19	0.44	0.22	0.14	0.21	0.19	0.19	0.17	
5	3	6	6	6	6	2<3	0.21	0.29	0.22	0.14					45
5	3	6	6	6	6	3-5	0.14	0.14	0.14	0.14					36
5	3	6	6	6	6	10	0.14	0.17	0.17	0.14					36
5	3	6	6	6	6	15	0.17	0.24	0.24	0.14					35
5	3	6	6	6	6	20	0.21	0.31	0.31	0.14					35
5	3	6	6	6	6	25	0.26	0.38	0.38	0.14					35
5	3	6	6	6	6	30	0.31	0.45	0.45	0.14					35
5	3	6	6	6	6	35	0.37	0.52	0.53	0.14					35
5 ft by 4 ft by 6 in.															
Span ft	Rise ft	Top in.	Bottom in.	Side in.	Haunch in.	Depth ft	Circumferential Reinforcement Areas, in. ² /ft								"M," in.
							A _{s1}	A _{s2}	A _{s3}	A _{s4}	A _{s5}	A _{s6}	A _{s7}	A _{s8}	
5	4	8	7	6	6	0<2	0.19	0.48	0.24	0.14	0.22	0.19	0.19	0.17	
5	4	6	6	6	6	2<3	0.18	0.33	0.25	0.14					45
5	4	6	6	6	6	3-5	0.14	0.16	0.16	0.14					45
5	4	6	6	6	6	10	0.14	0.19	0.19	0.14					36
5	4	6	6	6	6	15	0.14	0.26	0.27	0.14					35
5	4	6	6	6	6	20	0.18	0.33	0.34	0.14					35
5	4	6	6	6	6	25	0.21	0.41	0.42	0.14					35
5	4	6	6	6	6	30	0.26	0.49	0.49	0.14					35
5	4	6	6	6	6	35	0.30	0.56	0.57	0.14					35
5 ft by 5 ft by 6 in.															
Span ft	Rise ft	Top in.	Bottom in.	Side in.	Haunch in.	Depth ft	Circumferential Reinforcement Areas, in. ² /ft								"M," in.
							A _{s1}	A _{s2}	A _{s3}	A _{s4}	A _{s5}	A _{s6}	A _{s7}	A _{s8}	
5	5	8	7	6	6	0<2	0.19	0.50	0.26	0.14	0.24	0.19	0.19	0.17	
5	5	6	6	6	6	2<3	0.16	0.35	0.28	0.14					45
5	5	6	6	6	6	3-5	0.14	0.17	0.18	0.14					45
5	5	6	6	6	6	10	0.14	0.20	0.21	0.14					45
5	5	6	6	6	6	15	0.14	0.27	0.28	0.14					36
5	5	6	6	6	6	20	0.15	0.35	0.36	0.14					35
5	5	6	6	6	6	25	0.19	0.42	0.44	0.14					35
5	5	6	6	6	6	30	0.22	0.50	0.51	0.14					35
5	5	6	6	6	6	35	0.26	0.58	0.59	0.14					35
6 ft by 3 ft by 7 in.															
Span ft	Rise ft	Top in.	Bottom in.	Side in.	Haunch in.	Depth ft	Circumferential Reinforcement Areas, in. ² /ft								"M," in.
							A _{s1}	A _{s2}	A _{s3}	A _{s4}	A _{s5}	A _{s6}	A _{s7}	A _{s8}	
6	3	8	7	7	7	0<2	0.23	0.45	0.20	0.17	0.19	0.19	0.19	0.17	
6	3	7	7	7	7	2<3	0.24	0.30	0.20	0.17					43
6	3	7	7	7	7	3-5	0.17	0.17	0.17	0.17					40
6	3	7	7	7	7	10	0.17	0.20	0.20	0.17					39
6	3	7	7	7	7	15	0.23	0.27	0.28	0.17					38
6	3	7	7	7	7	20	0.30	0.35	0.36	0.17					38
6	3	7	7	7	7	25	0.36	0.44	0.44	0.17					38
6	3	7	7	7	7	30	0.43	0.52	0.52	0.17					38
6	3	7	7	7	7	35	0.50	0.60	0.60	0.17					38
6 ft by 4 ft by 7 in.															
Span ft	Rise ft	Top in.	Bottom in.	Side in.	Haunch in.	Depth ft	Circumferential Reinforcement Areas, in. ² /ft								"M," in.
							A _{s1}	A _{s2}	A _{s3}	A _{s4}	A _{s5}	A _{s6}	A _{s7}	A _{s8}	
6	4	8	7	7	7	0<2	0.19	0.49	0.23	0.17	0.21	0.19	0.19	0.17	

TABLE 1 *Continued*

6	4	7	7	7	7	2<3	0.21	0.33	0.23	0.17					43
6	4	7	7	7	7	3-5	0.17	0.17	0.17	0.17					40
6	4	7	7	7	7	10	0.17	0.22	0.23	0.17					39
6	4	7	7	7	7	15	0.20	0.30	0.31	0.17					38
6	4	7	7	7	7	20	0.25	0.39	0.40	0.17					38
6	4	7	7	7	7	25	0.30	0.48	0.49	0.17					38
6	4	7	7	7	7	30	0.36	0.57	0.58	0.17					38
6	4	7	7	7	7	35	0.42	0.66	0.67	0.17					38

6 ft by 5 ft by 7 in.

Span ft	Rise ft	Top in.	Bottom in.	Side in.	Haunch in.	Depth ft	Circumferential Reinforcement Areas, in. ² /ft								"M," in.
							A _{s1}	A _{s2}	A _{s3}	A _{s4}	A _{s5}	A _{s6}	A _{s7}	A _{s8}	
6	5	8	7	7	7	0<2	0.19	0.52	0.25	0.17	0.22	0.19	0.19	0.17	
6	5	7	7	7	7	2<3	0.19	0.36	0.26	0.17					52
6	5	7	7	7	7	3-5	0.17	0.19	0.19	0.17					43
6	5	7	7	7	7	10	0.17	0.23	0.24	0.17					39
6	5	7	7	7	7	15	0.17	0.32	0.33	0.17					38
6	5	7	7	7	7	20	0.22	0.41	0.43	0.17					38
6	5	7	7	7	7	25	0.26	0.51	0.52	0.17					38
6	5	7	7	7	7	30	0.31	0.60	0.61	0.17					38
6	5	7	7	7	7	35	0.36	0.69	0.71	0.17					38

6 ft by 6 ft by 7 in.

Span ft	Rise ft	Top in.	Bottom in.	Side in.	Haunch in.	Depth ft	Circumferential Reinforcement Areas, in. ² /ft								"M," in.
							A _{s1}	A _{s2}	A _{s3}	A _{s4}	A _{s5}	A _{s6}	A _{s7}	A _{s8}	
6	6	8	7	7	7	0<2	0.19	0.54	0.27	0.17	0.23	0.19	0.19	0.17	
6	6	7	7	7	7	2<3	0.17	0.38	0.28	0.17					52
6	6	7	7	7	7	3-5	0.17	0.20	0.20	0.17					52
6	6	7	7	7	7	10	0.17	0.24	0.26	0.17					43
6	6	7	7	7	7	15	0.17	0.33	0.35	0.17					39
6	6	7	7	7	7	20	0.19	0.43	0.44	0.17					38
6	6	7	7	7	7	25	0.23	0.52	0.54	0.17					38
6	6	7	7	7	7	30	0.27	0.61	0.63	0.17					38
6	6	7	7	7	7	35	0.32	0.71	0.73	0.17					38

7 ft by 4 ft by 8 in.

Span ft	Rise ft	Top in.	Bottom in.	Side in.	Haunch in.	Depth ft	Circumferential Reinforcement Areas, in. ² /ft								"M," in.
							A _{s1}	A _{s2}	A _{s3}	A _{s4}	A _{s5}	A _{s6}	A _{s7}	A _{s8}	
7	4	8	8	8	8	0<2	0.26	0.49	0.21	0.19	0.19	0.19	0.19	0.19	
7	4	8	8	8	8	2<3	0.24	0.33	0.22	0.19					47
7	4	8	8	8	8	3-5	0.19	0.19	0.19	0.19					43
7	4	8	8	8	8	10	0.19	0.25	0.25	0.19					43
7	4	8	8	8	8	15	0.26	0.34	0.35	0.19					41
7	4	8	8	8	8	20	0.33	0.44	0.45	0.19					41
7	4	8	8	8	8	25	0.40	0.54	0.55	0.19					41
7	4	8	8	8	8	30	0.47	0.64	0.65	0.19					41
7	4	8	8	8	8	35	0.55	0.75	0.75	0.19					41

7 ft by 5 ft by 8 in.

Span ft	Rise ft	Top in.	Bottom in.	Side in.	Haunch in.	Depth ft	Circumferential Reinforcement Areas, in. ² /ft								"M," in.
							A _{s1}	A _{s2}	A _{s3}	A _{s4}	A _{s5}	A _{s6}	A _{s7}	A _{s8}	
7	5	8	8	8	8	0<2	0.23	0.52	0.24	0.19	0.21	0.19	0.19	0.19	
7	5	8	8	8	8	2<3	0.22	0.36	0.25	0.19					59
7	5	8	8	8	8	3-5	0.19	0.20	0.20	0.19					43
7	5	8	8	8	8	10	0.19	0.27	0.28	0.19					43
7	5	8	8	8	8	15	0.23	0.37	0.38	0.19					41
7	5	8	8	8	8	20	0.29	0.48	0.49	0.19					41
7	5	8	8	8	8	25	0.35	0.58	0.59	0.19					41
7	5	8	8	8	8	30	0.41	0.69	0.70	0.19					41
7	5	8	8	8	8	35	0.47	0.80	0.81	0.19					41

7 ft by 6 ft by 8 in.

Span ft	Rise ft	Top in.	Bottom in.	Side in.	Haunch in.	Depth ft	Circumferential Reinforcement Areas, in. ² /ft								"M," in.
							A _{s1}	A _{s2}	A _{s3}	A _{s4}	A _{s5}	A _{s6}	A _{s7}	A _{s8}	
7	6	8	8	8	8	0<2	0.21	0.54	0.26	0.19	0.22	0.19	0.19	0.19	
7	6	8	8	8	8	2<3	0.20	0.39	0.27	0.19					59
7	6	8	8	8	8	3-5	0.19	0.22	0.22	0.19					47
7	6	8	8	8	8	10	0.19	0.28	0.30	0.19					43
7	6	8	8	8	8	15	0.20	0.39	0.40	0.19					41
7	6	8	8	8	8	20	0.26	0.50	0.51	0.19					41

TABLE 1 *Continued*

7	6	8	8	8	8	25	0.31	0.61	0.62	0.19						41
7	6	8	8	8	8	30	0.36	0.72	0.73	0.19						41
7	6	8	8	8	8	35	0.42	0.83	0.85	0.19						41
7 ft by 7 ft by 8 in.																
Span ft	Rise ft	Top in.	Bottom in.	Side in.	Haunch in.	Depth ft	Circumferential Reinforcement Areas, in. ² /ft								"M," in.	
							A _{s1}	A _{s2}	A _{s3}	A _{s4}	A _{s5}	A _{s6}	A _{s7}	A _{s8}		
7	7	8	8	8	8	0<2	0.19	0.56	0.27	0.19	0.22	0.19	0.19	0.19		
7	7	8	8	8	8	2<3	0.19	0.41	0.29	0.19						59
7	7	8	8	8	8	3-5	0.19	0.23	0.23	0.19						59
7	7	8	8	8	8	10	0.19	0.29	0.31	0.19						47
7	7	8	8	8	8	15	0.19	0.40	0.42	0.19						43
7	7	8	8	8	8	20	0.24	0.51	0.53	0.19						41
7	7	8	8	8	8	25	0.28	0.62	0.64	0.19						41
7	7	8	8	8	8	30	0.33	0.73	0.75	0.19						41
7	7	8	8	8	8	35	0.38	0.84	0.87	0.19						41
8 ft by 4 ft by 8 in.																
Span ft	Rise ft	Top in.	Bottom in.	Side in.	Haunch in.	Depth ft	Circumferential Reinforcement Areas, in. ² /ft								"M," in.	
							A _{s1}	A _{s2}	A _{s3}	A _{s4}	A _{s5}	A _{s6}	A _{s7}	A _{s8}		
8	4	8	8	8	8	0<2	0.31	0.53	0.23	0.19	0.20	0.19	0.19	0.19		
8	4	8	8	8	8	2<3	0.30	0.39	0.25	0.19						50
8	4	8	8	8	8	3-5	0.20	0.22	0.22	0.19						45
8	4	8	8	8	8	10	0.27	0.31	0.32	0.19						45
8	4	8	8	8	8	15	0.37	0.43	0.44	0.19						41
8	4	8	8	8	8	20	0.47	0.56	0.57	0.19						41
8	4	8	8	8	8	25	0.58	0.68	0.69	0.19						41
8 ft by 5 ft by 8 in.																
Span ft	Rise ft	Top in.	Bottom in.	Side in.	Haunch in.	Depth ft	Circumferential Reinforcement Areas, in. ² /ft								"M," in.	
							A _{s1}	A _{s2}	A _{s3}	A _{s4}	A _{s5}	A _{s6}	A _{s7}	A _{s8}		
8	5	8	8	8	8	0<2	0.28	0.57	0.25	0.19	0.21	0.19	0.19	0.19		
8	5	8	8	8	8	2<3	0.27	0.42	0.28	0.19						50
8	5	8	8	8	8	3-5	0.19	0.24	0.24	0.19						50
8	5	8	8	8	8	10	0.24	0.33	0.35	0.19						45
8	5	8	8	8	8	15	0.33	0.46	0.48	0.19						41
8	5	8	8	8	8	20	0.42	0.60	0.61	0.19						41
8	5	8	8	8	8	25	0.51	0.73	0.75	0.19						41
8 ft by 6 ft by 8 in.																
Span ft	Rise ft	Top in.	Bottom in.	Side in.	Haunch in.	Depth ft	Circumferential Reinforcement Areas, in. ² /ft								"M," in.	
							A _{s1}	A _{s2}	A _{s3}	A _{s4}	A _{s5}	A _{s6}	A _{s7}	A _{s8}		
8	6	8	8	8	8	0<2	0.26	0.59	0.28	0.19	0.22	0.19	0.19	0.19		
8	6	8	8	8	8	2<3	0.25	0.45	0.30	0.19						55
8	6	8	8	8	8	3-5	0.19	0.26	0.26	0.19						50
8	6	8	8	8	8	10	0.22	0.35	0.37	0.19						45
8	6	8	8	8	8	15	0.30	0.49	0.51	0.19						41
8	6	8	8	8	8	20	0.38	0.63	0.65	0.19						41
8	6	8	8	8	8	25	0.46	0.77	0.79	0.19						41
8 ft by 7 ft by 8 in.																
Span ft	Rise ft	Top in.	Bottom in.	Side in.	Haunch in.	Depth ft	Circumferential Reinforcement Areas, in. ² /ft								"M," in.	
							A _{s1}	A _{s2}	A _{s3}	A _{s4}	A _{s5}	A _{s6}	A _{s7}	A _{s8}		
8	7	8	8	8	8	0<2	0.24	0.62	0.30	0.19	0.23	0.19	0.19	0.19		
8	7	8	8	8	8	2<3	0.23	0.47	0.33	0.19						65
8	7	8	8	8	8	3-5	0.19	0.27	0.28	0.19						55
8	7	8	8	8	8	10	0.20	0.37	0.39	0.19						45
8	7	8	8	8	8	15	0.28	0.51	0.53	0.19						41
8	7	8	8	8	8	20	0.35	0.65	0.68	0.19						41
8	7	8	8	8	8	25	0.42	0.80	0.82	0.19						41
8 ft by 8 ft by 8 in.																
Span ft	Rise ft	Top in.	Bottom in.	Side in.	Haunch in.	Depth ft	Circumferential Reinforcement Areas, in. ² /ft								"M," in.	
							A _{s1}	A _{s2}	A _{s3}	A _{s4}	A _{s5}	A _{s6}	A _{s7}	A _{s8}		
8	8	8	8	8	8	0<2	0.22	0.64	0.32	0.19	0.24	0.19	0.19	0.19		
8	8	8	8	8	8	2<3	0.22	0.49	0.35	0.19						65
8	8	8	8	8	8	3-5	0.19	0.29	0.30	0.19						65
8	8	8	8	8	8	10	0.19	0.38	0.41	0.19						50
8	8	8	8	8	8	15	0.26	0.52	0.55	0.19						45

TABLE 1 *Continued*

8	8	8	8	8	8	20	0.33	0.66	0.70	0.19					45
8	8	8	8	8	8	25	0.40	0.81	0.84	0.19					41
9 ft by 5 ft by 9 in.															
Span ft	Rise ft	Top in.	Bottom in.	Side in.	Haunch in.	Depth ft	Circumferential Reinforcement Areas, in. ² /ft								"M," in.
							A _{s1}	A _{s2}	A _{s3}	A _{s4}	A _{s5}	A _{s6}	A _{s7}	A _{s8}	
9	5	9	9	9	9	0<2	0.29	0.53	0.25	0.22	0.22	0.22	0.22	0.22	
9	5	9	9	9	9	2<3	0.29	0.41	0.27	0.22					54
9	5	9	9	9	9	3-5	0.22	0.25	0.26	0.22					49
9	5	9	9	9	9	10	0.29	0.36	0.38	0.22					49
9	5	9	9	9	9	15	0.40	0.51	0.52	0.22					44
9	5	9	9	9	9	20	0.51	0.65	0.67	0.22					44
9	5	9	9	9	9	25	0.62	0.80	0.81	0.22					44
9 ft by 6 ft by 9 in.															
Span ft	Rise ft	Top in.	Bottom in.	Side in.	Haunch in.	Depth ft	Circumferential Reinforcement Areas, in. ² /ft								"M," in.
							A _{s1}	A _{s2}	A _{s3}	A _{s4}	A _{s5}	A _{s6}	A _{s7}	A _{s8}	
9	6	9	9	9	9	0<2	0.27	0.56	0.27	0.22	0.22	0.22	0.22	0.22	
9	6	9	9	9	9	2<3	0.26	0.44	0.30	0.22					59
9	6	9	9	9	9	3-5	0.22	0.27	0.28	0.22					54
9	6	9	9	9	9	10	0.27	0.39	0.41	0.22					49
9	6	9	9	9	9	15	0.36	0.54	0.56	0.22					44
9	6	9	9	9	9	20	0.46	0.69	0.71	0.22					44
9	6	9	9	9	9	25	0.56	0.84	0.86	0.22					44
9 ft by 7 ft by 9 in.															
Span ft	Rise ft	Top in.	Bottom in.	Side in.	Haunch in.	Depth ft	Circumferential Reinforcement Areas, in. ² /ft								"M," in.
							A _{s1}	A _{s2}	A _{s3}	A _{s4}	A _{s5}	A _{s6}	A _{s7}	A _{s8}	
9	7	9	9	9	9	0<2	0.25	0.58	0.29	0.22	0.22	0.22	0.22	0.22	
9	7	9	9	9	9	2<3	0.25	0.46	0.32	0.22					59
9	7	9	9	9	9	3-5	0.22	0.28	0.30	0.22					54
9	7	9	9	9	9	10	0.25	0.41	0.43	0.22					49
9	7	9	9	9	9	15	0.34	0.56	0.59	0.22					44
9	7	9	9	9	9	20	0.42	0.72	0.74	0.22					44
9	7	9	9	9	9	25	0.51	0.88	0.90	0.22					44
9 ft by 8 ft by 9 in.															
Span ft	Rise ft	Top in.	Bottom in.	Side in.	Haunch in.	Depth ft	Circumferential Reinforcement Areas, in. ² /ft								"M," in.
							A _{s1}	A _{s2}	A _{s3}	A _{s4}	A _{s5}	A _{s6}	A _{s7}	A _{s8}	
9	8	9	9	9	9	0<2	0.23	0.60	0.32	0.22	0.22	0.22	0.22	0.22	
9	8	9	9	9	9	2<3	0.23	0.48	0.34	0.22					72
9	8	9	9	9	9	3-5	0.22	0.30	0.32	0.22					59
9	8	9	9	9	9	10	0.23	0.42	0.45	0.22					54
9	8	9	9	9	9	15	0.31	0.58	0.61	0.22					44
9	8	9	9	9	9	20	0.39	0.74	0.77	0.22					44
9	8	9	9	9	9	25	0.48	0.90	0.93	0.22					44
9 ft by 9 ft by 9 in.															
Span ft	Rise ft	Top in.	Bottom in.	Side in.	Haunch in.	Depth ft	Circumferential Reinforcement Areas, in. ² /ft								"M," in.
							A _{s1}	A _{s2}	A _{s3}	A _{s4}	A _{s5}	A _{s6}	A _{s7}	A _{s8}	
9	9	9	9	9	9	0<2	0.22	0.62	0.34	0.22	0.22	0.22	0.22	0.22	
9	9	9	9	9	9	2<3	0.22	0.50	0.37	0.22					72
9	9	9	9	9	9	3-5	0.22	0.31	0.34	0.22					72
9	9	9	9	9	9	10	0.22	0.43	0.47	0.22					59
9	9	9	9	9	9	15	0.30	0.59	0.63	0.22					49
9	9	9	9	9	9	20	0.37	0.75	0.79	0.22					49
9	9	9	9	9	9	25	0.45	0.92	0.96	0.22					44
10 ft by 5 ft by 10 in.															
Span ft	Rise ft	Top in.	Bottom in.	Side in.	Haunch in.	Depth ft	Circumferential Reinforcement Areas, in. ² /ft								"M," in.
							A _{s1}	A _{s2}	A _{s3}	A _{s4}	A _{s5}	A _{s6}	A _{s7}	A _{s8}	
10	5	10	10	10	10	0<2	0.29	0.51	0.24	0.24	0.24	0.24	0.24	0.24	
10	5	10	10	10	10	2<3	0.30	0.41	0.27	0.24					58
10	5	10	10	10	10	3-5	0.24	0.26	0.27	0.24					52
10	5	10	10	10	10	10	0.35	0.39	0.41	0.24					52
10	5	10	10	10	10	15	0.47	0.55	0.56	0.24					47
10	5	10	10	10	10	20	0.60	0.70	0.72	0.24					47
10	5	10	10	10	10	25	0.73	0.86	0.87	0.24					47
10	5	10	10	10	10	30	0.86	1.02	1.03	0.24					47

TABLE 1 *Continued*

10 ft by 6 ft by 10 in.															
Span ft	Rise ft	Top in.	Bottom in.	Side in.	Haunch in.	Depth ft	Circumferential Reinforcement Areas, in. ² /ft								"M," in.
							A _{s1}	A _{s2}	A _{s3}	A _{s4}	A _{s5}	A _{s6}	A _{s7}	A _{s8}	
10	6	10	10	10	10	0<2	0.27	0.53	0.27	0.24	0.24	0.24	0.24	0.24	
10	6	10	10	10	10	2<3	0.27	0.43	0.29	0.24					58
10	6	10	10	10	10	3-5	0.24	0.28	0.30	0.24					52
10	6	10	10	10	10	10	0.32	0.42	0.44	0.24					52
10	6	10	10	10	10	15	0.43	0.58	0.60	0.24					47
10	6	10	10	10	10	20	0.55	0.75	0.77	0.24					47
10	6	10	10	10	10	25	0.66	0.91	0.93	0.24					47
10 ft by 7 ft by 10 in.															
Span ft	Rise ft	Top in.	Bottom in.	Side in.	Haunch in.	Depth ft	Circumferential Reinforcement Areas, in. ² /ft								"M," in.
							A _{s1}	A _{s2}	A _{s3}	A _{s4}	A _{s5}	A _{s6}	A _{s7}	A _{s8}	
10	7	10	10	10	10	0<2	0.25	0.55	0.29	0.24	0.24	0.24	0.24		
10	7	10	10	10	10	2<3	0.26	0.45	0.32	0.24					64
10	7	10	10	10	10	3-5	0.24	0.30	0.32	0.24					58
10	7	10	10	10	10	10	0.30	0.44	0.47	0.24					52
10	7	10	10	10	10	15	0.40	0.61	0.64	0.24					47
10	7	10	10	10	10	20	0.51	0.78	0.81	0.24					47
10	7	10	10	10	10	25	0.61	0.96	0.98	0.24					47
10 ft by 8 ft by 10 in.															
Span ft	Rise ft	Top in.	Bottom in.	Side in.	Haunch in.	Depth ft	Circumferential Reinforcement Areas, in. ² /ft								"M," in.
							A _{s1}	A _{s2}	A _{s3}	A _{s4}	A _{s5}	A _{s6}	A _{s7}	A _{s8}	
10	8	10	10	10	10	0<2	0.24	0.57	0.31	0.24	0.24	0.24	0.24		
10	8	10	10	10	10	2<3	0.25	0.47	0.34	0.24					64
10	8	10	10	10	10	3-5	0.24	0.32	0.34	0.24					58
10	8	10	10	10	10	10	0.28	0.46	0.49	0.24					52
10	8	10	10	10	10	15	0.37	0.63	0.67	0.24					47
10	8	10	10	10	10	20	0.47	0.81	0.84	0.24					47
10	8	10	10	10	10	25	0.57	0.99	1.02	0.24					47
10 ft by 9 ft by 10 in.															
Span ft	Rise ft	Top in.	Bottom in.	Side in.	Haunch in.	Depth ft	Circumferential Reinforcement Areas, in. ² /ft								"M," in.
							A _{s1}	A _{s2}	A _{s3}	A _{s4}	A _{s5}	A _{s6}	A _{s7}	A _{s8}	
10	9	10	10	10	10	0<2	0.24	0.59	0.34	0.24	0.24	0.24	0.24		
10	9	10	10	10	10	2<3	0.24	0.49	0.36	0.24					79
10	9	10	10	10	10	3-5	0.24	0.33	0.36	0.24					64
10	9	10	10	10	10	10	0.27	0.48	0.52	0.24					58
10	9	10	10	10	10	15	0.35	0.65	0.69	0.24					47
10	9	10	10	10	10	20	0.44	0.83	0.87	0.24					47
10	9	10	10	10	10	25	0.53	1.01	1.05	0.24					47
10 ft by 10 ft by 10 in.															
Span ft	Rise ft	Top in.	Bottom in.	Side in.	Haunch in.	Depth ft	Circumferential Reinforcement Areas, in. ² /ft								"M," in.
							A _{s1}	A _{s2}	A _{s3}	A _{s4}	A _{s5}	A _{s6}	A _{s7}	A _{s8}	
10	10	10	10	10	10	0<2	0.24	0.60	0.36	0.24	0.24	0.24	0.24		
10	10	10	10	10	10	2<3	0.24	0.51	0.39	0.24					79
10	10	10	10	10	10	3-5	0.24	0.35	0.39	0.24					70
10	10	10	10	10	10	10	0.25	0.49	0.54	0.24					64
10	10	10	10	10	10	15	0.34	0.67	0.72	0.24					52
10	10	10	10	10	10	20	0.42	0.85	0.90	0.24					52
10	10	10	10	10	10	25	0.51	1.03	1.08	0.24					47
11 ft by 4 ft by 11 in.															
Span ft	Rise ft	Top in.	Bottom in.	Side in.	Haunch in.	Depth ft	Circumferential Reinforcement Areas, in. ² /ft								"M," in.
							A _{s1}	A _{s2}	A _{s3}	A _{s4}	A _{s5}	A _{s6}	A _{s7}	A _{s8}	
11	4	11	11	11	11	0<2	0.32	0.46	0.26	0.26	0.26	0.26	0.26		
11	4	11	11	11	11	2<3	0.34	0.37	0.26	0.26					62
11	4	11	11	11	11	3-5	0.29	0.26	0.26	0.26					62
11	4	11	11	11	11	10	0.44	0.38	0.40	0.26					55
11	4	11	11	11	11	15	0.60	0.54	0.55	0.26					55
11	4	11	11	11	11	20	0.77	0.69	0.70	0.26					55
11	4	11	11	11	11	25	0.94	0.84	0.86	0.26					55

TABLE 1 *Continued*

11 ft by 6 ft by 11 in.															
Span ft	Rise ft	Top in.	Bottom in.	Side in.	Haunch in.	Depth ft	Circumferential Reinforcement Areas, in. ² /ft								"M," in.
							A _{s1}	A _{s2}	A _{s3}	A _{s4}	A _{s5}	A _{s6}	A _{s7}	A _{s8}	
11	6	11	11	11	11	0<2	0.28	0.51	0.27	0.26	0.26	0.26	0.26	0.26	
11	6	11	11	11	11	2<3	0.29	0.43	0.29	0.26					62
11	6	11	11	11	11	3-5	0.26	0.30	0.31	0.26					55
11	6	11	11	11	11	10	0.37	0.45	0.47	0.26					55
11	6	11	11	11	11	15	0.51	0.63	0.65	0.26					50
11	6	11	11	11	11	20	0.64	0.80	0.82	0.26					50
11	6	11	11	11	11	25	0.78	0.98	1.00	0.26					50
11 ft by 8 ft by 11 in.															
Span ft	Rise ft	Top in.	Bottom in.	Side in.	Haunch in.	Depth ft	Circumferential Reinforcement Areas, in. ² /ft								"M," in.
							A _{s1}	A _{s2}	A _{s3}	A _{s4}	A _{s5}	A _{s6}	A _{s7}	A _{s8}	
11	8	11	11	11	11	0<2	0.26	0.55	0.31	0.26	0.26	0.26	0.26		
11	8	11	11	11	11	2<3	0.26	0.47	0.34	0.26					69
11	8	11	11	11	11	3-5	0.26	0.34	0.36	0.26					62
11	8	11	11	11	11	10	0.33	0.50	0.53	0.26					55
11	8	11	11	11	11	15	0.44	0.69	0.72	0.26					50
11	8	11	11	11	11	20	0.55	0.88	0.91	0.26					50
11	8	11	11	11	11	25	0.67	1.07	1.11	0.26					50
11 ft by 10 ft by 11 in.															
Span ft	Rise ft	Top in.	Bottom in.	Side in.	Haunch in.	Depth ft	Circumferential Reinforcement Areas, in. ² /ft								"M," in.
							A _{s1}	A _{s2}	A _{s3}	A _{s4}	A _{s5}	A _{s6}	A _{s7}	A _{s8}	
11	10	11	11	11	11	0<2	0.26	0.58	0.36	0.26	0.26	0.26	0.26		
11	10	11	11	11	11	2<3	0.26	0.50	0.39	0.26					86
11	10	11	11	11	11	3-5	0.26	0.37	0.41	0.26					69
11	10	11	11	11	11	10	0.30	0.54	0.59	0.26					62
11	10	11	11	11	11	15	0.40	0.73	0.78	0.26					50
11	10	11	11	11	11	20	0.49	0.93	0.98	0.26					50
11	10	11	11	11	11	25	0.59	1.13	1.18	0.26					50
11 ft by 11 ft by 11 in.															
Span ft	Rise ft	Top in.	Bottom in.	Side in.	Haunch in.	Depth ft	Circumferential Reinforcement Areas, in. ² /ft								"M," in.
							A _{s1}	A _{s2}	A _{s3}	A _{s4}	A _{s5}	A _{s6}	A _{s7}	A _{s8}	
11	11	11	11	11	11	0<2	0.26	0.59	0.38	0.26	0.26	0.26	0.26		
11	11	11	11	11	11	2<3	0.26	0.51	0.41	0.26					86
11	11	11	11	11	11	3-5	0.26	0.39	0.43	0.26					75
11	11	11	11	11	11	10	0.29	0.55	0.61	0.26					69
11	11	11	11	11	11	15	0.38	0.75	0.81	0.26					55
11	11	11	11	11	11	20	0.47	0.94	1.00	0.26					55
11	11	11	11	11	11	25	0.57	1.14	1.20	0.26					55
12 ft by 4 ft by 12 in.															
Span ft	Rise ft	Top in.	Bottom in.	Side in.	Haunch in.	Depth ft	Circumferential Reinforcement Areas, in. ² /ft								"M," in.
							A _{s1}	A _{s2}	A _{s3}	A _{s4}	A _{s5}	A _{s6}	A _{s7}	A _{s8}	
12	4	12	12	12	12	0<2	0.32	0.44	0.29	0.29	0.29	0.29	0.29		
12	4	12	12	12	12	2<3	0.36	0.37	0.29	0.29					73
12	4	12	12	12	12	3-5	0.33	0.29	0.29	0.29					66
12	4	12	12	12	12	10	0.50	0.41	0.42	0.29					59
12	4	12	12	12	12	15	0.69	0.57	0.58	0.29					59
12	4	12	12	12	12	20	0.88	0.73	0.75	0.29					59
12	4	12	12	12	12	25	1.07	0.90	0.91	0.29					59
12	4	12	12	12	12	30	1.27	1.06	1.07	0.29					59
12 ft by 6 ft by 12 in.															
Span ft	Rise ft	Top in.	Bottom in.	Side in.	Haunch in.	Depth ft	Circumferential Reinforcement Areas, in. ² /ft								"M," in.
							A _{s1}	A _{s2}	A _{s3}	A _{s4}	A _{s5}	A _{s6}	A _{s7}	A _{s8}	
12	6	12	12	12	12	0<2	0.29	0.49	0.29	0.29	0.29	0.29	0.29		
12	6	12	12	12	12	2<3	0.31	0.42	0.29	0.29					66
12	6	12	12	12	12	3-5	0.29	0.32	0.33	0.29					59
12	6	12	12	12	12	10	0.43	0.48	0.50	0.29					59
12	6	12	12	12	12	15	0.59	0.67	0.69	0.29					53
12	6	12	12	12	12	20	0.74	0.86	0.88	0.29					53
12	6	12	12	12	12	25	0.90	1.05	1.07	0.29					53
12	6	12	12	12	12	30	1.06	1.24	1.26	0.29					53

TABLE 1 Continued

12 ft by 8 ft by 12 in.																
Span ft	Rise ft	Top in.	Bottom in.	Side in.	Haunch in.	Depth ft	Circumferential Reinforcement Areas, in. ² /ft								"M," in.	
							A _{s1}	A _{s2}	A _{s3}	A _{s4}	A _{s5}	A _{s6}	A _{s7}	A _{s8}		
12	8	12	12	12	12	0<2	0.29	0.52	0.31	0.29	0.29	0.29	0.29	0.29		
12	8	12	12	12	12	2<3	0.29	0.46	0.34	0.29					66	
12	8	12	12	12	12	3-5	0.29	0.36	0.38	0.29					59	
12	8	12	12	12	12	10	0.38	0.54	0.57	0.29					59	
12	8	12	12	12	12	15	0.51	0.74	0.78	0.29					53	
12	8	12	12	12	12	20	0.64	0.95	0.98	0.29					53	
12	8	12	12	12	12	25	0.77	1.15	1.19	0.29					53	
12	8	12	12	12	12	30	0.91	1.36	1.40	0.29					53	

12 ft by 10 ft by 12 in.																
Span ft	Rise ft	Top in.	Bottom in.	Side in.	Haunch in.	Depth ft	Circumferential Reinforcement Areas, in. ² /ft								"M," in.	
							A _{s1}	A _{s2}	A _{s3}	A _{s4}	A _{s5}	A _{s6}	A _{s7}	A _{s8}		
12	10	12	12	12	12	0<2	0.29	0.55	0.36	0.29	0.29	0.29	0.29	0.29		
12	10	12	12	12	12	2<3	0.29	0.49	0.39	0.29					80	
12	10	12	12	12	12	3-5	0.29	0.40	0.43	0.29					66	
12	10	12	12	12	12	10	0.35	0.58	0.63	0.29					59	
12	10	12	12	12	12	15	0.46	0.79	0.84	0.29					53	
12	10	12	12	12	12	20	0.57	1.01	1.06	0.29					53	
12	10	12	12	12	12	25	0.69	1.22	1.27	0.29					53	

12 ft by 12 ft by 12 in.																
Span ft	Rise ft	Top in.	Bottom in.	Side in.	Haunch in.	Depth ft	Circumferential Reinforcement Areas, in. ² /ft								"M," in.	
							A _{s1}	A _{s2}	A _{s3}	A _{s4}	A _{s5}	A _{s6}	A _{s7}	A _{s8}		
12	12	12	12	12	12	0<2	0.29	0.58	0.41	0.29	0.29	0.29	0.29	0.29		
12	12	12	12	12	12	2<3	0.29	0.52	0.44	0.29					93	
12	12	12	12	12	12	3-5	0.29	0.43	0.48	0.29					80	
12	12	12	12	12	12	10	0.32	0.61	0.68	0.29					73	
12	12	12	12	12	12	15	0.42	0.83	0.90	0.29					59	
12	12	12	12	12	12	20	0.53	1.04	1.12	0.29					59	
12	12	12	12	12	12	25	0.63	1.26	1.33	0.29					59	

Tea Sanaadk
<http://taadk.com.ai>
 Document Preview

ASTM C1433-04e1

<https://standards.iteh.ai/catalog/standards/sist/677bfb68-0e98-41e8-a891-5cddec03f0f0/astm-c1433-04e1>

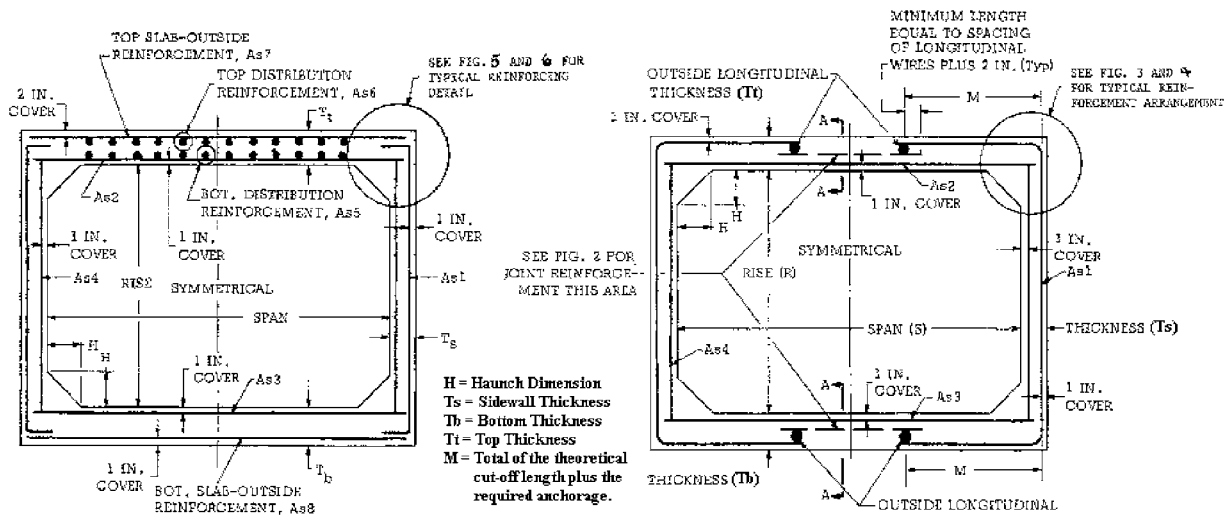

Fill Height Less than 2 ft

Fill Height 2 ft and Greater

FIG. 1 Typical Box Sections

TABLE 2 Design Requirements for Precast Concrete Box Sections Under Earth Dead and Interstate Live Load Conditions

NOTE 1—Design earth covers and reinforcement areas are based on the weight of a column of earth over the width of the box section as defined in Appendix X1.

NOTE 2—Concrete design strength 5000 psi.

NOTE 3—The design earth cover indicated is the height of fill above the top of the box section. Design requirements are based on the material and soil properties, loading data, and typical section as included in Appendix X1. For alternative or special designs, see 7.2.

NOTE 4—Design steel area in square inches per linear foot of box section at those locations which are indicated on the typical section included in Fig. 1.

NOTE 5—The top section designation, for example, 3 ft by 2 ft by 4 in. indicates (interior horizontal span in feet) by (interior vertical rise in feet) by (wall and slab thickness in inches).

NOTE 6—In accordance with the acceptance criteria in 7.2, the manufacturer may interpolate the steel area requirements for fill heights between noted increments or may submit independent designs.

3 ft by 2 ft by 4 in.																
Span ft	Rise ft	Top in.	Bottom in.	Side in.	Haunch in.	Depth ft	Circumferential Reinforcement Areas, in. ² /ft								"M," in.	
							A _{s1}	A _{s2}	A _{s3}	A _{s4}	A _{s5}	A _{s6}	A _{s7}	A _{s8}		
3	2	7	6	4	4	0<2	0.17	0.38	0.21	0.10	0.19	0.17	0.17	0.14		
3	2	4	4	4	4	2<3	0.13	0.21	0.21	0.10					31	
3	2	4	4	4	4	3-5	0.10	0.10	0.10	0.10					31	
3	2	4	4	4	4	10	0.10	0.10	0.10	0.10					31	
3	2	4	4	4	4	15	0.10	0.14	0.14	0.10					31	
3	2	4	4	4	4	20	0.11	0.18	0.19	0.10					31	
3	2	4	4	4	4	25	0.14	0.23	0.23	0.10					31	
3	2	4	4	4	4	30	0.17	0.27	0.27	0.10					31	
3	2	4	4	4	4	35	0.20	0.31	0.31	0.10					31	
3 ft by 3 ft by 4 in.																
Span ft	Rise ft	Top in.	Bottom in.	Side in.	Haunch in.	Depth ft	Circumferential Reinforcement Areas, in. ² /ft								"M," in.	
							A _{s1}	A _{s2}	A _{s3}	A _{s4}	A _{s5}	A _{s6}	A _{s7}	A _{s8}		
3	3	7	6	4	4	0<2	0.17	0.40	0.23	0.10	0.20	0.17	0.17	0.14		
3	3	4	4	4	4	2<3	0.10	0.25	0.25	0.10					31	
3	3	4	4	4	4	3-5	0.10	0.10	0.11	0.10					31	
3	3	4	4	4	4	10	0.10	0.10	0.11	0.10					31	
3	3	4	4	4	4	15	0.10	0.15	0.16	0.10					31	
3	3	4	4	4	4	20	0.10	0.20	0.20	0.10					31	
3	3	4	4	4	4	25	0.10	0.24	0.25	0.10					31	
3	3	4	4	4	4	30	0.12	0.29	0.29	0.10					31	
3	3	4	4	4	4	35	0.14	0.33	0.34	0.10					31	
4 ft by 2 ft by 5 in.																
Span ft	Rise ft	Top in.	Bottom in.	Side in.	Haunch in.	Depth ft	Circumferential Reinforcement Areas, in. ² /ft								"M," in.	
							A _{s1}	A _{s2}	A _{s3}	A _{s4}	A _{s5}	A _{s6}	A _{s7}	A _{s8}		
4	2	7.5	6	5	5	0<2	0.18	0.40	0.20	0.12	0.20	0.18	0.18	0.14		
4	2	5	5	5	5	2<3	0.21	0.23	0.20	0.12					38	
4	2	5	5	5	5	3-5	0.12	0.12	0.12	0.12					38	
4	2	5	5	5	5	10	0.12	0.12	0.13	0.12					38	
4	2	5	5	5	5	15	0.15	0.18	0.18	0.12					38	
4	2	5	5	5	5	20	0.19	0.23	0.23	0.12					38	
4	2	5	5	5	5	25	0.23	0.28	0.28	0.12					38	
4	2	5	5	5	5	30	0.28	0.33	0.33	0.12					38	
4	2	5	5	5	5	35	0.33	0.38	0.39	0.12					38	
4 ft by 3 ft by 5 in.																
Span ft	Rise ft	Top in.	Bottom in.	Side in.	Haunch in.	Depth ft	Circumferential Reinforcement Areas, in. ² /ft								"M," in.	
							A _{s1}	A _{s2}	A _{s3}	A _{s4}	A _{s5}	A _{s6}	A _{s7}	A _{s8}		
4	3	7.5	6	5	5	0<2	0.18	0.45	0.23	0.12	0.22	0.18	0.18	0.14		
4	3	5	5	5	5	2<3	0.16	0.28	0.25	0.12					38	
4	3	5	5	5	5	3-5	0.12	0.12	0.13	0.12					38	
4	3	5	5	5	5	10	0.12	0.14	0.15	0.12					38	
4	3	5	5	5	5	15	0.12	0.20	0.21	0.12					38	
4	3	5	5	5	5	20	0.14	0.26	0.26	0.12					38	
4	3	5	5	5	5	25	0.18	0.32	0.32	0.12					38	
4	3	5	5	5	5	30	0.21	0.38	0.38	0.12					38	
4	3	5	5	5	5	35	0.25	0.44	0.44	0.12					38	