



Designation: D4761 – 05

Standard Test Methods for Mechanical Properties of Lumber and Wood-Base Structural Material¹

This standard is issued under the fixed designation D4761; the number immediately following the designation indicates the year of original adoption or, in the case of revision, the year of last revision. A number in parentheses indicates the year of last reapproval. A superscript epsilon (ε) indicates an editorial change since the last revision or reapproval.

INTRODUCTION

Numerous evaluations of the mechanical properties of wood-based structural material have been satisfactorily conducted since the late 1920s, using Test Methods D198. Those methods are best suited to a laboratory environment and are adaptable to a variety of products such as stress-graded lumber, sawn timber, laminated timbers, wood-plywood composite members, reinforced and prestressed timbers.

The procedures presented in these test methods have been derived from those set forth in Test Methods D198. They are intended primarily for application to stress-graded lumber, but can be used for other wood-base structural material as well. The procedures are more flexible than those in Test Methods D198, making testing in a nonlaboratory environment more feasible. Thus the test methods can be used on production sites for field testing and quality control, as well as in laboratories for research applications. Key differences from Test Methods D198 are the testing speed, the deflection-measuring procedures for test specimens under load, and the detail of data reporting. Furthermore, the test methods do not require that specimens be loaded to failure (Note 1).

Since these test methods allow latitude in testing procedures, the procedures used shall be fully documented in the test report. It may also be desirable to correlate the results from tests carried out according to these test methods with test results obtained through the use of a traditional procedure, such as that set forth in Test Methods D198.

1. Scope

NOTE 1—A proof load may be used, which will permit the determination of a specified strength percentile without testing the total sample to destruction. Designing a test program on the basis of proof loading can be complex, requiring consideration in relation to the objectives of the test program. Guidance on this matter can be found in the paper by Johnson.²

1.1 These test methods cover the determination of the mechanical properties of stress-graded lumber and other wood-base structural material.

1.2 These test methods appear in the following order:

	Section
Bending edge-wise	6-11
Bending flat-wise:	
Center point loading	12-17
Third point loading	18-23
Axial strength in tension	24-29

¹ These test methods are under the jurisdiction of ASTM Committee D07 on Wood and are the direct responsibility of Subcommittee D07.01 on Fundamental Test Methods & Properties.

Current edition approved April 1, 2005. Published April 2005. Originally approved in 1988. Last previous edition approved in 2002 as D4761 – 02a. DOI: 10.1520/D4761-05.

² Johnson, R. A., "Current Statistical Methods for Estimating Lumber Properties by Proof Loading," *Forest Products Journal*, Vol 30, No. 1, 1980, pp. 14–22.

Axial strength in compression

30-35

1.3 *This standard does not purport to address all of the safety concerns, if any, associated with its use. It is the responsibility of the user of this standard to establish appropriate safety and health practices and determine the applicability of regulatory limitations prior to use.*

2. Referenced Documents

2.1 *ASTM Standards:*³

D9 Terminology Relating to Wood and Wood-Based Products

D198 Test Methods of Static Tests of Lumber in Structural Sizes

D2915 Practice for Evaluating Allowable Properties for Grades of Structural Lumber

D4442 Test Methods for Direct Moisture Content Measurement of Wood and Wood-Base Materials

E4 Practices for Force Verification of Testing Machines

³ For referenced ASTM standards, visit the ASTM website, www.astm.org, or contact ASTM Customer Service at service@astm.org. For *Annual Book of ASTM Standards* volume information, refer to the standard's Document Summary page on the ASTM website.

E6 Terminology Relating to Methods of Mechanical Testing
E177 Practice for Use of the Terms Precision and Bias in ASTM Test Methods

2.2 *Other Document*.⁴

NIST Voluntary Product Standard PS20 American Softwood Lumber Standard

NOTE 2—The current version of PS20 is given as an example of a product standard applicable to stress-graded lumber. Other product standards may apply to stress-graded lumber. For wood-base structural materials other than stress-graded lumber, relevant product standards may apply.

3. Terminology

3.1 *Definitions*—See Terminologies **D9** and **E6** and Practices **E4** and **E177** for definitions of terms used in these test methods.

3.2 *Definitions of Terms Specific to This Standard*:

3.2.1 *breadth*—that dimension of the test specimen in the direction perpendicular to the span and perpendicular to the direction of an applied bending load.

3.2.2 *depth*—that dimension of the test specimen in the direction perpendicular to the span and parallel to the direction of an applied bending load.

3.2.3 *span*—the distance between the center lines of end reactions on which the test specimen is supported to accommodate a transverse bending load or, for tension loading, the distance between the grips.

4. Significance and Use

4.1 These test methods provide procedures that are applicable under true field conditions, such as in a plant with specimens not at moisture equilibrium.

4.2 The data established by these test methods can be used as follows:

4.2.1 Develop strength and stiffness properties for the population represented by the material being tested (that is, individual grades, grade combinations, species, species groups, or any other defined, identifiable sample).

4.2.2 Confirm the validity of strength and stiffness properties for the population represented by the material being tested.

4.2.3 Investigate the effect of parameters that may influence the strength and stiffness properties of the material, such as moisture content, temperature, knot size and location, or slope of grain.

4.3 The procedures chosen in accordance with these test methods shall be fully documented in the report to facilitate correlation with test results obtained through the use of traditional procedures, such as those set forth in Test Methods **D198**.

5. Precision and Bias

5.1 The precision and bias of these test methods have not yet been established.

BENDING EDGE-WISE

6. Scope

6.1 This test method provides procedures for the determination of the strength and modulus of elasticity of stress-graded lumber and other wood-base structural material in bending edge-wise.

7. Summary of Test Method

7.1 The test specimen is simply supported and loaded by two concentrated forces spaced equidistant from the supports. The specimen is loaded at a prescribed rate and, as applicable, observation of load or deflection, or both, is made until failure occurs or a preselected load is reached.

8. Apparatus

8.1 *Testing Machine*—A device that combines (1) a reaction frame to support the test specimen, (2) a loading mechanism for applying load at a specified rate, and (3) a force-measuring apparatus that can be calibrated to the accuracy requirements of **8.3.2** following the procedures outlined in Practices **E4**.

8.1.1 *Load and Support Apparatus*, including bearing plates at least as wide as the specimen is broad and not exceeding 8 in. (200 mm) in length. It is recommended that, under this test method, the bearing plate length of the loading apparatus be no less than one half the specimen depth. The apparatus shall also include appropriate mechanisms, such as rollers or pivots, to minimize the development of axial forces in the test specimen.

8.1.2 *Loading Configuration*—The simply supported test specimen shall be subjected to two equal transverse concentrated loads spaced equidistant from the supports.

NOTE 3—The apparent modulus of elasticity varies for different loading configurations (see Practice **D2915**). While the loading configuration that commonly serves as the basis for assigning design values assumes a uniformly distributed load, a configuration with two concentrated loads symmetrically placed within the test span usually is more suitable for structural tests. This configuration also produces a constant bending moment, free of shear, in the portion of the specimen between the load points.

8.1.3 *Lateral Supports*, when necessary, to restrict the specimen lateral deflection. Specimens having a depth-to-breadth ratio of three or greater are subject to lateral instability during loading and may require lateral supports. These supports shall allow movement of the specimen in the direction of load application and have minimal frictional restraint.

8.2 *Deflection-Measuring Apparatus*, for modulus of elasticity calculations, to monitor the deflection of the test specimen. Deflection may be measured directly as the displacement of the loading head of the testing machine. In this case, deflection is expressed as the average deflection of the load points with respect to the end reaction plates. If, because of the design of the apparatus, the deflection measurement includes extraneous components, the deflection data may be adjusted for such extraneous components (**Note 4**). In all instances, the report shall include a complete description of test conditions, extraneous components, and data adjustment procedures.

NOTE 4—If the extraneous components are an appreciable portion of the total measurement, the test apparatus should be reexamined for its suitability.

⁴ Available from National Institute of Standards and Technology (NIST), 100 Bureau Dr., Stop 3460, Gaithersburg, MD 20899-3460.

8.3 Accuracy:

8.3.1 The two load points shall be located within $\frac{1}{8}$ in. (3 mm) of the distance determined in accordance with 8.1.2 and 9.2.2.

8.3.2 The force-measuring apparatus shall be such as to permit load measurements with an error not to exceed $\pm 1.0\%$ of the load for loads greater than or equal to 1000 lbf (4450 N). For loads smaller than 1000 lbf, the error shall not exceed ± 10 lbf (45 N).

8.3.3 The deflection-measuring apparatus shall be such as to permit deflection measurements with an error not to exceed $\pm 2.0\%$ of the deflection for deflections greater than or equal to 0.150 in. (4 mm). For deflections smaller than 0.150 in., the error shall not exceed ± 0.003 in. (0.08 mm).

9. Test Specimen

9.1 *Cross Section*—Unless the effect of cross-section modifications is a test evaluation objective, test the specimen without modifying the dimensions of the commercial cross section.

9.2 Length:

9.2.1 The minimum specimen length shall be the span, determined in accordance with 9.2.2, plus an extension beyond the center lines of the end reactions to accommodate the bearing plates, such that the specimen will not slip off the end reactions during the test. In cases where the unsupported specimen length outside the test span at an end reaction (overhang) exceeds 10 times the specimen depth, report the amount of overhang at each end reaction.

9.2.2 The span will depend on the purpose of the test program. It is customary to express the span as a multiple of the test specimen depth (Note 5). While spans that currently serve as a basis suitable for testing range from 17 times the depth of the specimen to 21 times the depth, other spans may be used under this test method. Practice D2915 gives an indication of the variation of the apparent modulus of elasticity with span-to-depth ratios.

NOTE 5—The depth here refers to the relevant size specified in the size classification of the applicable product standard (for stress-graded lumber, for example, the depth here may refer to the dressed dry size specified in the size classification of the current version of PS20 for the nominal size, for example, 3.5 in. (89 mm) for a nominal 4 in.).

9.3 *Conditioning*—Specimens may be tested as produced or conditioned (for example, temperature, moisture content, or treatment), depending on the purpose of the test program. If the temperature of the specimens at the time of testing is less than 45°F (7°C) or more than 90°F (32°C), report that temperature.

10. Procedure

10.1 Specimen Measurements:

10.1.1 Measure and record before testing the cross-sectional dimensions and moisture content of every specimen for which the modulus of elasticity or the modulus of rupture, or both, are to be calculated. Make measurements at midlength of the specimen unless another location is more appropriate to the purpose of the test.

10.1.2 Measure the cross-sectional dimensions of the specimen to the nearest 0.04 in. (1 mm).

10.1.3 Measure the moisture content of the specimen in accordance with the procedures outlined in Test Methods D4442.

10.2 Test Setup:

10.2.1 *Lengthwise Positioning*—If the specimen is to be located within the test span without bias regarding defects, achieve this by centering the specimen in the span or by any other scheme suitable to the purpose of the test program.

10.2.2 *Selection of the Tension Edge*—Randomly select the edge to be subjected to tension testing.

10.3 *Speed of Testing*—The test rate shall be such that the sample target failure load would be achieved in approximately 1 min (Note 6). The failure load should not be reached in less than 10 s nor more than 10 min (Note 7).

NOTE 6—Some caution is warranted here. A test rate to achieve the average failure load for the sample in approximately 1 min will differ from that to achieve a lower percentile load for the same sample in approximately 1 min.

NOTE 7—For stress-graded lumber, a rate of motion of the testing machine loading head of approximately 3 in. (75 mm)/min will usually permit the test to be completed in the prescribed time for span to depth ratios of 17:1 and in cases where the target failure load is the average failure load for the sample.

10.4 *Load-Deflection Data*—Obtain load-deflection data, as required, using the apparatus specified in 8.2.

NOTE 8—For stress-graded lumber, data obtained for loads corresponding to maximum stresses in the specimen ranging from 400 to 1000 psi (2.75 to 7 MPa) will usually be adequate for modulus of elasticity calculations.

10.5 *Maximum Load*—If the purpose of the test is to determine strength properties, record the maximum load attained in the test.

NOTE 9—In proof loading, the intended load target may not be reached or may be exceeded slightly. The actual attained load as well as the target load should therefore be recorded.

10.6 *Record of Failure*—Depending on the purpose of the test, a description of the characteristic causing failure, and its location within the test span, may be required.

NOTE 10—An example of a coding scheme for recording characteristic type and failure location is given in Appendix X1. This example was derived for application to stress-graded lumber.

11. Report

11.1 The report content depends on the purpose of the test program. The report shall include, at the minimum, the following information:

11.1.1 Description of the testing machine, including detailed drawings, the span, and the deflection-measuring apparatus, if applicable.

11.1.2 Description of calibration procedures, frequency, and records.

11.1.3 Method used for the measurement of the moisture content of specimens.

11.1.4 Speed of testing and means of control of the speed of testing.

11.1.5 Specimens lengthwise positioning and selection of the tension edge.

11.1.6 As applicable, the type of load-deflection data for the calculation of the modulus of elasticity of specimens, including a description of test conditions, extraneous components, and data adjustment procedures in accordance with 8.2.

11.1.7 Description of the population sampled, including (1) geographical origin, (2) species or species group, (3) specimen geometry (for example, nominal cross section and length), (4) grade or grades combination, and (5) an indication of specimen treatment at the time of production (for example, drying schedule and preservation), if applicable.

11.1.8 Description of the sample, including (1) sample size, (2) conditioning, if applicable, (3) temperature of specimens at the time of testing, and (4) number of specimens that failed during the test.

11.1.9 Data on test specimens, including, as applicable, (1) grade, (2) actual cross-sectional dimensions, (3) moisture content, (4) overhang in accordance with 9.2.1, (5) load-deflection data, (6) maximum load, (7) time to maximum load, and (8) failure description and location.

11.1.10 Details of any deviations from the prescribed or recommended procedures as outlined in this test method.

BENDING FLAT-WISE—CENTER-POINT LOADING

12. Scope

12.1 This test method provides procedures for the determination of long-span modulus of elasticity of lumber and other wood-base structural material in flat-wise bending under center-point load.

13. Definition of Modulus of Elasticity

13.1 Long-span modulus of elasticity (E) is defined as the modulus of elasticity calculated from deflection measured in a flat-wise test of lumber with center point loading and a span-depth ratio (l/d) of approximately 100 (90 to 110).

14. Summary of Test Method

14.1 A known concentrated load is applied at mid-span of a simply supported piece of lumber oriented flatwise. A dial indicator is used to determine the deflection of the lumber piece under the load. The modulus of elasticity (E) is determined by relating the deflection to the size of lumber and the test span.

15. Apparatus

15.1 *Support System*—Any may be used that provides unrestrained support at both ends. The support at one end should be constructed so that stability is provided for a piece of twisted lumber, such as a pedestal with a single point bearing support, a support that is designed to tilt to match the twist of the lumber, or special shims that restrain the lumber from rocking on the supports.

15.2 *Dial Indicator*, with the capacity to measure deflections up to at least 1 in. (25 mm) to the nearest 0.001 in. (0.025 mm).

15.3 A weight of approximately 5 lbf (22.24 N) to be used for preloading. Compact calibrated accurately (to 0.05 lbf) (0.22 N) weights for loading.

NOTE 11—Three 5-lbf (22.24 N) weights and one 10-lbf (44.5 N) weight have been found to provide an adequate combination of weights

for 2 by 4 through 2 by 12 surfaced dimension lumber sizes.

16. Procedure

16.1 Space the supports to provide a span-to-depth ratio for the test specimen of approximately 100 (90 to 110). This spacing shall be determined to plus or minus 1/8 in. (3 mm) for use in the calculation of the modulus of elasticity.

16.2 Place the dial indicator midway between the supports and adjust it so the downward deflection of the lumber can be measured when loaded. Construct or arrange the apparatus such that the relative position of the dial indicator to the supports is not changed more than 0.001 in. (0.025 mm) when the load weight is placed on the test specimen.

16.3 Place the test specimen flatwise on the supports and in firm contact with both end supports.

16.4 Apply the preload weight to the test specimen at or near the center of the span.

16.5 Then apply the load weight(s) to the test specimen at the center of the span. This load shall be such that it will induce 0.2 in. (5 mm) or more deflection in a specimen with 2.0×10^6 psi (13 790 MPa) long-span modulus of elasticity.

16.6 Observe the dial indicator to determine the deflection of the test specimen due to the load weight(s).

16.7 Long-span modulus of elasticity is determined using the following equation:

$$E = PL^3/(48dI)$$

where:

E = modulus of elasticity, psi $\times 10^6$,
 P = load, lbf,
 L = span, in.,
 d = deflection, and
 I = moment of inertia, in.⁴

17. Report

17.1 The content of the report depends on the purpose of the test program. The report shall include, at the minimum, all applicable information as presented in Section 11.

BENDING FLAT-WISE—THIRD-POINT LOADING

18. Scope

18.1 This test method provides procedures for the determination of bending strength and modulus of elasticity of stress-graded lumber and other wood base structural material in flat-wise bending on short spans under third-point load.

19. Summary of Test Method

19.1 The test specimen is simply supported and loaded on the wide face by two equal, concentrated forces spaced equidistant between the supports. The specimen is loaded at a prescribed rate and, as applicable, observation of load or deflection, or both, is made until failure occurs or a preselected load or deflection is reached.

19.2 For modulus of elasticity calculation, a step-wise load may be used, for example, pre-loading and then adding a known weight for deflection measurement.

20. Apparatus

20.1 *Testing Machine*—A device that combines (1) a reaction frame to support the test specimen; (2) a loading mechanism for applying load at a specified rate or prescribed load interval; and (3) a force-measuring apparatus that can be calibrated to the accuracy requirements of 8.3.2, following the procedures outlined in Practices E4. If the test is for modulus of elasticity only, no force-measuring device is required. Fig. 1 illustrates the traditional device meeting the requirements of these test methods for modulus of elasticity measurement.

20.1.1 *Load and Support Apparatus*, including bearing plates at least as wide as the specimen is broad. It is recommended that the bearing plate length be no less than one half the specimen depth. If only the modulus of elasticity is to be determined in accordance with 19.2, the bearing plate requirement may be waived. The apparatus shall also include appropriate mechanisms such as rollers or pivots to minimize the development of axial forces in the test specimen.

20.1.2 *Loading Configuration*—The simply supported test specimen shall be subjected to two equal, concentrated loads spaced equidistant between the supports. (See Note 3).

20.1.3 If an incremental load system is used for modulus of elasticity, the pre-load shall be sufficient to force the specimen into contact with the supports, firmly seat moveable parts, and produce sufficient deflection to permit establishing the base for the incremental measurement. The known incremental load shall be of sufficient magnitude to produce deflection greater than 0.050 in.

NOTE 12—In North American practice, these incremental loads are selected to give deflections ranging from 0.070 in. (1.8 mm) to 0.210 in. (5.3 mm), with a minus tolerance of approximately 10 %, at respective E levels of 1.0 and 3.0×10^6 psi (6.9 GPa and 21 GPa) for dimension sizes ranging from 2 by 3 to 2 by 10 (38 by 63 to 38 by 235 mm).

NOTE 13—As the span/depth ratio decreases, the magnitude of the applied load must be increased to produce deflections in the range required by 20.1.3. Stability of the applied load is a safety consideration in design of the apparatus. For high loads, the applied loads may need to be hung rather than supported as shown in Fig. 1. These higher loads may also increase deflections in the support apparatus.

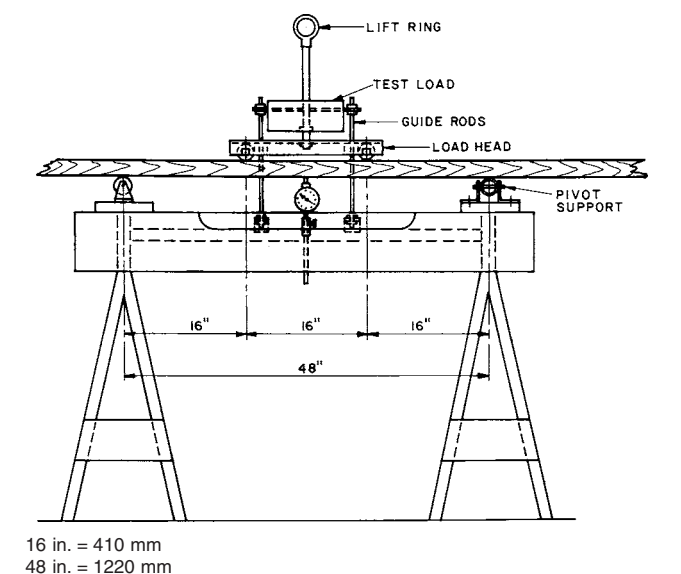

NOTE 1—This device is used for assessment of E in third-point, flat-wise bending on a span-to-depth ratio of 32 for 1½-in. (38-mm) thick lumber.

FIG. 1 Schematic of Static Bending Testing Device

20.1.4 Deflections in the support system shall be measured to determine that either they are negligible or that calibration of the system can compensate for the deflections. (See also 20.2).

NOTE 13—As the span/depth ratio decreases, the magnitude of the applied load must be increased to produce deflections in the range required by 20.1.3. Stability of the applied load is a safety consideration in design of the apparatus. For high loads, the applied loads may need to be hung rather than supported as shown in Fig. 1. These higher loads may also increase deflections in the support apparatus.

20.2 *Deflection-Measuring Apparatus*, for modulus of elasticity calculations, to monitor the deflection of the test specimen. Deflection may be measured directly as the displacement of the loading head of the testing machine. In this case, deflection is expressed as the average deflection of the load points with respect to the end reactions. If, because of the design of the apparatus, the deflection measurement includes extraneous components, the deflection data may be adjusted for such extraneous components (Note 4). In all instances, the report shall include a complete description of test conditions, extraneous components, and data adjustment procedures.

20.2.1 If an incremental load is applied for determination of modulus of elasticity, the deflection-measuring device shall be suitable for measuring the deflection caused by the incremental load.

20.3 *Accuracy*:

20.3.1 The two load points shall be located within ⅛ in. (3 mm) of the distance determined in accordance with 20.1.2 and 21.2.2.

20.3.2 The force-measuring apparatus shall be such as to permit load measurements with an error not to exceed ± 1.0 % of the load for loads greater than or equal to 1000 lbf (4450 N). For loads smaller than 1000 lbf, the error shall not exceed ± 10 lbf (45 N).

20.3.2.1 For modulus of elasticity based on incremental loads, these loads shall be calibrated to within ± 1 % of the stipulated value.

20.3.3 The deflection-measuring apparatus shall be such as to permit deflection measurements with an error not to exceed ± 2.0 % of the deflection for deflections greater than or equal to 0.150 in. (4 mm). For deflections smaller than 0.150 in., the error shall not exceed ± 0.003 in. (0.08 mm).

21. Test Specimen

21.1 *Cross Section*—Unless the effect of cross-section modifications is a test evaluation objective, test the specimen without modifying the dimensions of the commercial cross section.

21.2 *Length*:

21.2.1 The minimum specimen test length shall be the span, determined in accordance with 9.2, plus an extension beyond the center lines of the end reactions to accommodate the bearing plates, such that the specimen will not slip off the end reactions during the test.

21.2.2 Because this is a short-span test, the length of the specimen will often exceed the test length of 21.2.1. A sampling procedure shall specify where, along the specimen length, the test length shall be positioned.

21.2.2.1 The standard span for this test is 32 times the depth for nominal 2 in. (38 mm) lumber. Other spans/depth ratios are

AXIAL STRENGTH IN TENSION

permissible but load levels and within-piece sampling methods shall be carefully documented, noting changes from the traditional span/depth ratio.

21.3 *Conditioning*—Specimens may be tested as produced or as conditioned (for example, temperature, moisture content, or treatment), depending on the purpose of the test program. If the temperature of the specimens at the time of testing is less than 45°F (7°C) or more than 90°F (32°C), report that temperature.

22. Procedure

22.1 *Specimen Measurement*—The procedures of 10.1 shall be followed.

22.2 Test Setup:

22.2.1 *Lengthwise Positioning*—The objective may be to locate the test span within the total length without bias regarding defects, or it may be to locate the test span at locations predetermined by specified criteria. This positioning shall be achieved by a within-piece sampling plan that specifies the method of locating the test area (see 21.2.2). The procedure shall be documented (see Section 23).

22.2.1.1 If this method is being used to determine specimen strength, after the test location is determined, the specimen length shall be adjusted if necessary to provide equal extension over both test supports (prevent unequal overhang).

22.2.1.2 If this method is being used for modulus of elasticity only, unequal extension beyond the supports is permitted. A weight may be placed directly over a support to stabilize the specimen where a long extension (overhang) is present.

22.3 Rate of Load Application:

22.3.1 *Strength and Modulus of Elasticity by Continuous Loading*—The practices of 10.3 shall be followed.

22.3.2 *Modulus of Elasticity by Incremental Test*—If the incremental loading method is used, a pre-load shall be applied, followed by the incremental load. Loads shall be applied and deflections recorded rapidly to prevent the influence of creep.

NOTE 14—It is common North American practice to complete the pre-load, deflection zero, prescribed load application, and the incremental deflection measurement within approximately 6 s.

22.4 *Load-Deflection Data*—Obtain load-deflection data, as required, using the apparatus specified in 20.2.

22.5 *Maximum Load*—If the purpose of the test is to determine strength properties, record the maximum load attained in the test.

NOTE 15—In proof loading, the intended load target may not be reached or may be exceeded slightly. For some applications, it is recommended that both the actual attained load and the target load be recorded.

22.6 *Record of Failure*—Depending on the purpose of the test, a description of the characteristic causing failure, and its location within the test span, may be required. (See Note 10.)

23. Report

23.1 The content of the report depends on the purpose of the test program. The report shall include, at the minimum, all applicable information as outlined in Section 11.

24. Scope

24.1 This test method provides procedures for the determination of the axial tensile strength of stress-graded lumber and other wood-base structural material.

25. Summary of Test Method

25.1 The specimen is subjected to an axial tensile load applied near its ends. The specimen is loaded at a prescribed rate and observation of load is made until failure occurs or a preselected load is reached.

26. Apparatus

26.1 *Testing Machine*, combining (1) a loading mechanism for applying an axial tensile load at a specified rate and (2) a force-measuring apparatus that can be calibrated to the accuracy requirements of 26.3 following procedures outlined in Practices E4.

26.2 *Grips or Clamping Devices*, to transmit the tensile load from the testing machine to the test specimen such that (1) the specimen damage due to clamping is minimized and (2) slippage is minimized during load application.

26.2.1 *Distance Between Grips*—The clear distance between grips depends on the purpose of the test program and the material being tested.

NOTE 16—It is recommended that, for stress-graded lumber, the clear distance between grips be, at the minimum, 25 times the width of the test specimen in order to minimize problems of end fixity and to properly account for the effect of grain deviations on strength. Because of practical limitations on the use of equipment for field testing, this may not always be feasible for the wider width of stress-graded lumber, for which a clear distance between grips less than 12 times the width of the test specimen is not recommended. The width here refers to the dressed dry size specified in the size classification the current version of PS20. To minimize problems in the interpretation of data results, it is further recommended that all specimens be tested at a constant clear span between grips.

26.3 *Accuracy*—The force-measuring apparatus shall be such as to permit load measurements with an error not to exceed $\pm 2.0\%$ of the load.

27. Test Specimen

27.1 *Cross Section*—See 9.1.

27.2 *Length*—The minimum specimen length shall be the clear distance between grips, determined in accordance with 26.2.1, plus any required length to achieve contact along the full length of the grips.

27.3 *Conditioning*—See 9.3.

28. Procedure

28.1 *Specimen Measurements:*

28.1.1 Measure and record before testing the cross-sectional dimensions and moisture content of every specimen for which the tensile strength is to be calculated. Make measurements at midlength of the specimen unless another location is more appropriate to the purpose of the test.

28.1.2 *Accuracy of Measurements of the Cross-Sectional Dimensions*—See 10.1.2.