**Fine ceramics (advanced ceramics,
advanced technical ceramics) —
Determination of the in-plane shear
strength of continuous-fibre-reinforced
composites at ambient temperature by
the Iosipescu test**

iTeh STANDARD PREVIEW

(standards.iteh.ai)
*Céramiques techniques — Détermination de la résistance au
cisaillement plan des composites renforcés de fibres continues à
température ambiante par l'essai de Iosipescu*

[ISO 20506:2005](#)

<https://standards.iteh.ai/catalog/standards/sist/fab3d1cf-93dd-4d41-9302-b0ea090bc1b9/iso-20506-2005>



PDF disclaimer

This PDF file may contain embedded typefaces. In accordance with Adobe's licensing policy, this file may be printed or viewed but shall not be edited unless the typefaces which are embedded are licensed to and installed on the computer performing the editing. In downloading this file, parties accept therein the responsibility of not infringing Adobe's licensing policy. The ISO Central Secretariat accepts no liability in this area.

Adobe is a trademark of Adobe Systems Incorporated.

Details of the software products used to create this PDF file can be found in the General Info relative to the file; the PDF-creation parameters were optimized for printing. Every care has been taken to ensure that the file is suitable for use by ISO member bodies. In the unlikely event that a problem relating to it is found, please inform the Central Secretariat at the address given below.

iTeh STANDARD PREVIEW
(standards.iteh.ai)

[ISO 20506:2005](#)

<https://standards.iteh.ai/catalog/standards/sist/fab3d1cf-93dd-4d41-9302-b0ea090bc1b9/iso-20506-2005>

© ISO 2005

All rights reserved. Unless otherwise specified, no part of this publication may be reproduced or utilized in any form or by any means, electronic or mechanical, including photocopying and microfilm, without permission in writing from either ISO at the address below or ISO's member body in the country of the requester.

ISO copyright office
Case postale 56 • CH-1211 Geneva 20
Tel. + 41 22 749 01 11
Fax + 41 22 749 09 47
E-mail copyright@iso.org
Web www.iso.org

Published in Switzerland

Contents

Page

Foreword.....	iv
1 Scope	1
2 Normative references	1
3 Terms and definitions	1
4 Symbols and designations	2
5 Principle	3
6 Interferences	4
6.1 Test environment	4
6.2 Preparation of test pieces	4
6.3 Failures outside gauge section	4
6.4 Clamping forces	4
6.5 Friction	4
6.6 Thin test pieces	4
7 Apparatus	4
7.1 Testing machines	4
7.2 Data acquisition	5
7.3 Dimension-measuring devices	5
7.4 Test fixture	5
8 Test piece	6
8.1 Test piece geometry	6
8.2 Test piece preparation	6
8.2.1 Customary practices	6
8.2.2 Standard procedures	7
8.2.3 Handling precautions	7
8.3 Number of test pieces	7
9 Precautionary statement	7
10 Test conditions	7
10.1 Test modes and rates	7
10.1.1 Displacement rate	7
10.1.2 Load rate	8
11 Procedure	8
11.1 Test piece dimensions	8
11.2 Preparations for testing	8
11.3 Conducting the test	8
11.3.1 Mount the test piece in the test fixture	8
11.3.2 Begin data acquisition	9
11.3.3 Initiate the action of the test machine	9
11.4 Completion of testing	9
11.5 Post test	11
12 Calculation of results	11
12.1 Shear strength	11
12.2 Statistics	11
13 Test report	12
Annex A (informative) Results of round-robin tests	13
Bibliography	15

Foreword

ISO (the International Organization for Standardization) is a worldwide federation of national standards bodies (ISO member bodies). The work of preparing International Standards is normally carried out through ISO technical committees. Each member body interested in a subject for which a technical committee has been established has the right to be represented on that committee. International organizations, governmental and non-governmental, in liaison with ISO, also take part in the work. ISO collaborates closely with the International Electrotechnical Commission (IEC) on all matters of electrotechnical standardization.

International Standards are drafted in accordance with the rules given in the ISO/IEC Directives, Part 2.

The main task of technical committees is to prepare International Standards. Draft International Standards adopted by the technical committees are circulated to the member bodies for voting. Publication as an International Standard requires approval by at least 75 % of the member bodies casting a vote.

Attention is drawn to the possibility that some of the elements of this document may be the subject of patent rights. ISO shall not be held responsible for identifying any or all such patent rights.

ISO 20506 was prepared by Technical Committee ISO/TC 206, *Fine ceramics*.

iTeh STANDARD PREVIEW (standards.iteh.ai)

[ISO 20506:2005](https://standards.iteh.ai/catalog/standards/sist/fab3d1cf-93dd-4d41-9302-b0ea090bc1b9/iso-20506-2005)

<https://standards.iteh.ai/catalog/standards/sist/fab3d1cf-93dd-4d41-9302-b0ea090bc1b9/iso-20506-2005>

Fine ceramics (advanced ceramics, advanced technical ceramics) — Determination of the in-plane shear strength of continuous-fibre-reinforced composites at ambient temperature by the Iosipescu test

1 Scope

This International Standard specifies a method for the determination of in-plane shear strength of continuous-fibre-reinforced ceramic composites at ambient temperature by the Iosipescu test. Methods for test piece fabrication, testing modes and rates (load rate or displacement rate), data collection, and reporting procedures are addressed.

This International Standard applies primarily to advanced ceramic or glass-matrix composites with continuous-fibre reinforcement having uni-directional (1-D), bi-directional (2-D) or 3-D fibre architecture. This test method does not address composites with discontinuous-fibre-reinforced, whisker-reinforced or particulate-reinforced ceramics.

iTeh STANDARD PREVIEW

NOTE 1 Values expressed in this International Standard are in accordance with the International System of Units (SI).

NOTE 2 This International Standard is based on ASTM C1292.

[ISO 20506:2005](https://standards.iteh.ai/catalog/standards/sist/fab3d1cf-93dd-4d41-9302-b0ea090bc1b9/iso-20506-2005)

<https://standards.iteh.ai/catalog/standards/sist/fab3d1cf-93dd-4d41-9302-b0ea090bc1b9/iso-20506-2005>

2 Normative references

The following referenced documents are indispensable for the application of this document. For dated references, only the edition cited applies. For undated references, the latest edition of the referenced document (including any amendments) applies.

ISO 3611, *Micrometer callipers for external measurement*

ISO 7500-1, *Metallic materials — Verification of static uniaxial testing machines — Part 1: Tension/compression testing machines — Verification and calibration of the force-measuring system*

ASTM C1292, *Standard Test Method for Shear Strength of Continuous Fiber-Reinforced Advanced Ceramics at Ambient Temperatures*

3 Terms and definitions

For the purposes of this document, the following terms and definitions apply:

3.1

fine ceramic (advanced ceramic, advanced technical ceramic)

highly engineered, high-performance predominately non-metallic, inorganic, ceramic material having specific functional attributes

3.2
continuous-fibre-reinforced ceramic composite
CFCC

ceramic matrix composite in which the reinforcing phase consists of a continuous fibre, continuous yarn, or a woven fabric

3.3
shear failure load

maximum load required to fracture a shear-loaded test piece

3.4
shear strength

maximum shear stress which a material is capable of sustaining

NOTE Shear strength is calculated from the shear-fracture load and the shear-loaded area.

4 Symbols and designations

Symbols used throughout this International Standard and their designations are given in Table 1.

Table 1 — Symbols and designations

Symbol	Designation	Unit	References
L	Test piece length	mm	Table 2
h	Distance between notches	mm	Table 2 Equation 2
w	Test piece width	mm	Table 2
t	Test piece thickness	mm	Table 2 Equation 2
R	Notch radius	mm	Table 2
θ	Notch angle	°	Table 2
n	Number of valid tests	1	Equations 3, 4
P_{max}	Maximum load	N	Equation 1
A	Shear area of test piece	mm ²	Equation 1
τ_{IP}	In-plane shear strength	MPa	Equation 1
\bar{X}	mean	MPa	Equation 3, 4, 5
SD	standard deviation	MPa	Equation 4
CV	Coefficient of variation	1	Equation 5

5 Principle

This International Standard is for material development, material comparison, quality assurance, characterization, reliability and design data generation. The in-plane shear strength of continuous-fibre-reinforced ceramic composites, as determined by this International Standard, is measured by the Iosipescu test. According to this test, the shear strength is determined by loading a test coupon in the form of a rectangular flat strip with symmetric, centrally located V-notches using a mechanical testing machine and a modified asymmetric four-point bending fixture. Failure of the test piece occurs by shear between the V-notches. Schematics of the test setup and the test piece are shown in Figures 1 and 2.

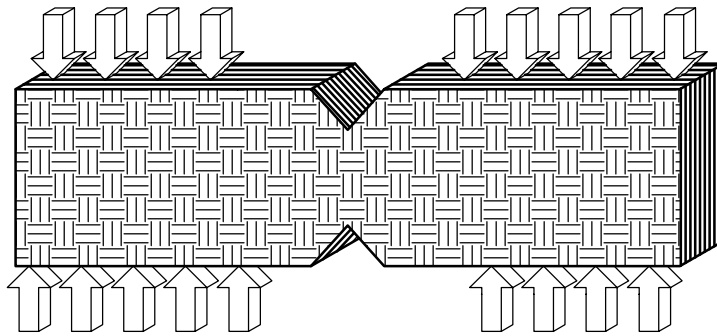

Figure 1 — Schematic of Iosipescu test piece subjected to asymmetric four-point bending

iTeh STANDARD PREVIEW
(standards.iteh.ai)

Dimensions in millimetres

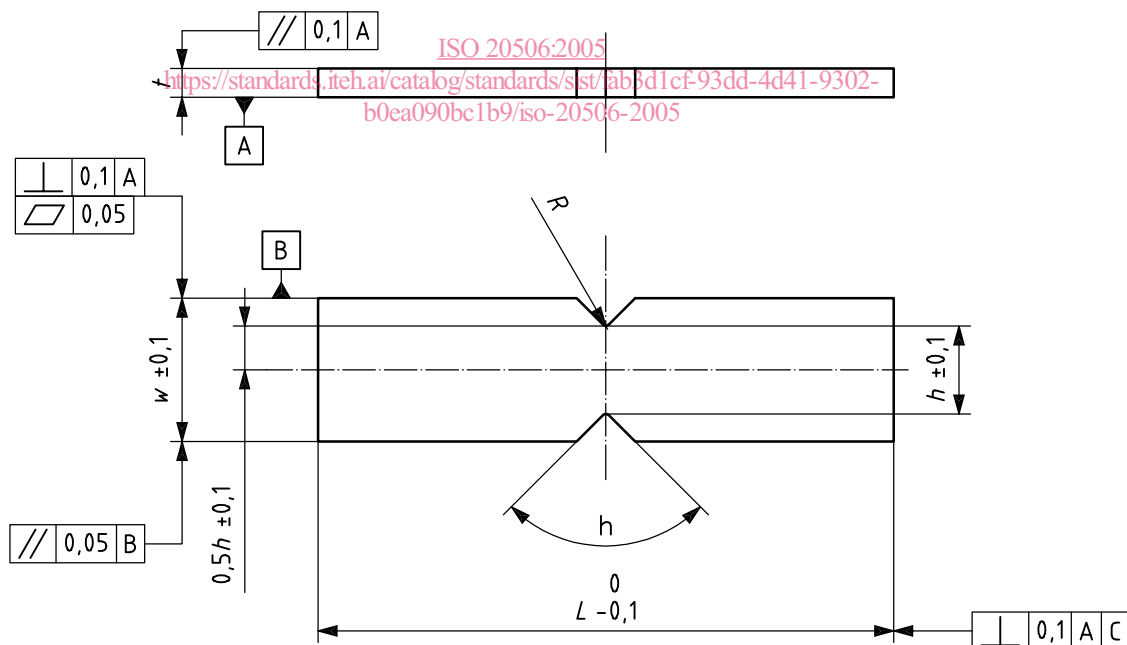

Figure 2 — Geometry and dimensions of Iosipescu test piece

6 Interferences

6.1 Test environment

The test environment may have an influence on the measured shear strength. In particular, the behaviour of materials susceptible to slow-crack-growth fracture will be strongly influenced by the test environment and testing rate. Testing to evaluate the maximum strength potential of a material shall be conducted in inert environments and/or at sufficiently rapid testing rates, so as to minimize slow-crack-growth effects. Conversely, testing can be conducted in environments and testing modes and rates representative of service conditions to evaluate material performance under those conditions. When testing is conducted in uncontrolled ambient air with the objective of evaluating maximum strength potential, relative humidity and temperature shall be monitored and reported.

6.2 Preparation of test pieces

Preparation of test pieces, although normally not considered a major concern with continuous-fibre-reinforced ceramic composites, can introduce fabrication flaws which may have pronounced effects on the mechanical properties and behaviour (e.g. shape and level of the resulting load-displacement curve and shear strength). Machining damage introduced during test piece preparation can be either a random interfering factor in the determination of shear strength of pristine material, or an inherent part of the strength characteristics to be measured. Universal or standardized test methods of surface preparation do not exist. Final machining steps may, or may not, negate machining damage introduced during the initial machining. Thus, the history of the test piece fabrication may play an important role in the measured strength distributions and shall be reported.

6.3 Failures outside gauge section

Fractures that initiate outside the uniformly stressed gauge section of a test piece may be due to extraneous stresses introduced by improper loading configurations, or strength-limiting features in the microstructure of the test piece. Such non-gauge section fractures will constitute invalid tests.

<https://standards.iteh.ai/catalog/standards/sist/fab3d1cf-93dd-4d41-9302-b0ea090bc1b9/iso-20506-2005>

6.4 Clamping forces

Excessive clamping force will induce undesirable pre-loading and may damage some materials.

6.5 Friction

Most fixtures for the Iosipescu test incorporate an alignment mechanism in the form of a guide rod and a linear roller bearing. Excessive free play or excessive friction in this mechanism may introduce spurious moments that will alter the ideal loading conditions.

6.6 Thin test pieces

Thin test pieces (width to thickness ratio of more than 10) may suffer from splitting and instabilities rendering, in turn, invalid test results.

7 Apparatus

7.1 Testing machines

The testing machine shall be verified in accordance with ISO 7500-1 and shall be at least grade 1,0.

7.2 Data acquisition

Obtain at least an autographic record of applied load and cross-head displacement versus time using either analogue chart recorders or digital data acquisition systems. Recording devices shall be accurate to within $\pm 1\%$ of the selected range for the testing equipment including readout unit, and have a minimum data acquisition rate of 10 Hz with a response of 50 Hz deemed more than sufficient.

7.3 Dimension-measuring devices

Micrometers and other devices used for measuring linear dimensions shall be accurate and precise to at least 0,01 mm and shall be in accordance with ISO 3611. To obtain consistent measurements of test piece dimensions, use a flat, anvil-type micrometer. Ball-tipped or sharp anvil micrometers are not recommended for woven continuous-fibre-reinforced ceramic composites, because the resulting measurements may be affected by the peaks and valleys of the weave. Measure test piece dimensions to within 0,02 mm.

7.4 Test fixture

The fixture for the Iosipescu test is a modified asymmetric four-point bending fixture. This fixture consists of a stationary element mounted on a base plate, and a movable element capable of vertical translation guided by a stiff post. The movable element is attached to the cross-head of the testing machine. Each element clamps half of the test piece into position with a wedge-action grip that is able to compensate for minor variations in test piece width. A span of 13 mm is left unsupported between fixture halves. An alignment tool is recommended to ensure that the test piece notch is aligned with the line-of-action of the loading fixture. Figures 3 and 4 show a photograph and a schematic of such a fixture.

iTeh STANDARD PREVIEW
(standards.iteh.ai)

ISO 20506:2005
<https://standards.iteh.ai/catalog/standards/sist/lab3d1ef93dd-4d41-9302-b0ea090bc1b9/iso-20506-2005>

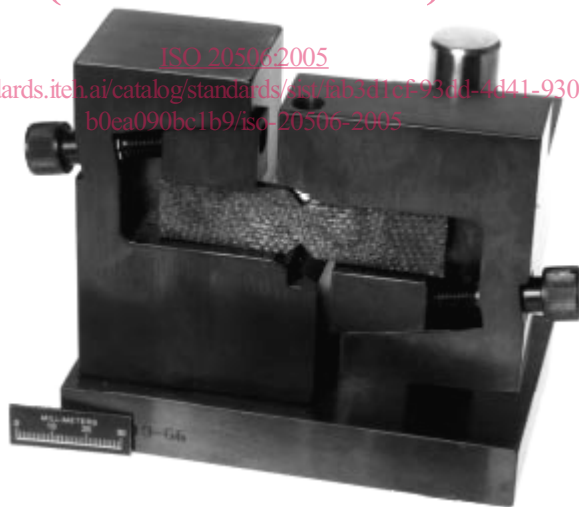
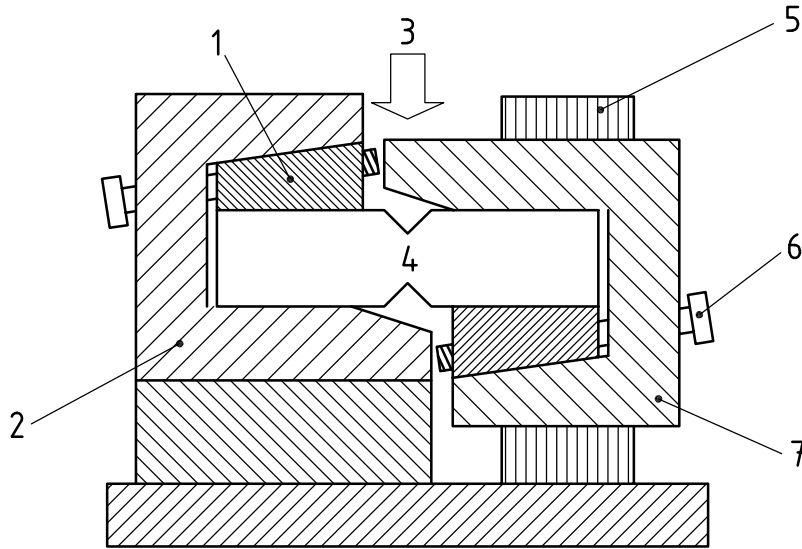

Figure 3 — Photograph of commercially available fixture for Iosipescu test



Key

- 1 adjustable wedge to tighten the specimen
- 2 stationary portion of fixture
- 3 load
- 4 specimen
- 5 fixture guide rod
- 6 wedge-adjusting screw
- 7 fixture attached to guide rod by linear rolling bearing

iTeh STANDARD PREVIEW
Figure 4 — Schematic of Iosipescu test fixture
 (standards.iteh.ai)

8 Test piece

[ISO 20506:2005](https://standards.iteh.ai/catalog/standards/sist/fab3d1cf-93dd-4d41-9302-b0ea090bc1b9/iso-20506-2005)

<https://standards.iteh.ai/catalog/standards/sist/fab3d1cf-93dd-4d41-9302-b0ea090bc1b9/iso-20506-2005>

8.1 Test piece geometry

The required shape and tolerances of the Iosipescu test piece are shown in Figure 2, and Table 2 contains recommended values for the dimensions of the test piece.

Table 2 — Recommended dimensions for Iosipescu test pieces

Dimension	Description	Value	Allowance
<i>L</i>	Test piece length	76,00 mm	± 0,1 mm
<i>h</i>	Distance between notches	11,00 mm	± 0,1 mm
<i>w</i>	Test piece width	19,00 mm	± 0,1 mm
<i>R</i>	Notch radius	1,30 mm	
<i>θ</i>	Notch angle	90,0°	
<i>t</i>	Test piece thickness	—	

8.2 Test piece preparation

8.2.1 Customary practices

In instances where a customary machining procedure has been developed that is completely satisfactory for a class of materials (that is, it induces no unwanted surface/subsurface damage or residual stresses), this procedure shall be used.

8.2.2 Standard procedures

Studies to evaluate the machinability of continuous-fibre-reinforced ceramic composites have not been completed. Therefore, the standard procedure of this subclause can be viewed as starting-point guidelines, but a more stringent procedure may be necessary.

All grinding or cutting shall be done with an ample supply of appropriate filtered coolant, to keep the workplace and grinding wheel constantly flooded and particles flushed. Grinding can be done in at least two stages, ranging from coarse to fine rate of material removal.

Stock removal rate shall be on the order of 0,03 mm per pass, using diamond tools that have between 320 and 600 grit. Remove equal stock from each face where applicable.

8.2.3 Handling precautions

Exercise care in the storing and handling of finished test pieces to avoid the introduction of severe flaws. In addition, direct attention to pre-test storage of test pieces in controlled environments or desiccators, to avoid unquantifiable environmental degradation of test pieces prior to testing.

8.3 Number of test pieces

A minimum of 5 valid test results is required for the purpose of estimating a mean. A greater number of tests may be necessary, if estimates regarding the form of the strength distribution are required.

9 Precautionary statement

During the conduct of this test method, the possibility of flying fragments of broken test material may be high. The brittle nature of advanced ceramics and the release of strain energy contribute to the potential release of uncontrolled fragments upon fracture. Means for containment and retention of these fragments for later fractographic reconstruction and analysis is highly recommended.

WARNING — Exposed fibres at the edges of continuous-fibre-reinforced ceramic composite test pieces present a hazard due to the sharpness and brittleness of the ceramic fibres. All persons required to handle these materials must be well informed of these conditions and the proper handling techniques.

10 Test conditions

10.1 Test modes and rates

Test modes may involve load or displacement control. Recommended rates of testing shall be sufficiently rapid to obtain the maximum possible shear strength at fracture of the material within 30 s. However, rates other than those recommended here may be used to evaluate rate effects. In all cases, the test mode and rate shall be reported.

Generally, displacement-controlled tests are employed in such cumulative damage or yielding deformation processes to prevent a 'runaway' condition (i.e. rapid uncontrolled deformation and fracture) characteristic of load- or stress-controlled tests. However, for sufficiently rapid test rates, differences in the fracture process may not be noticeable and any of these test modes may be appropriate.

10.1.1 Displacement rate

Use a constant cross-head displacement rate of 0,05 mm/s, unless otherwise found acceptable as determined in 10.1.2.