



Designation: F1160 – 05

# Standard Test Method for Shear and Bending Fatigue Testing of Calcium Phosphate and Metallic Medical and Composite Calcium Phosphate/ Metallic Coatings<sup>1</sup>

This standard is issued under the fixed designation F1160; the number immediately following the designation indicates the year of original adoption or, in the case of revision, the year of last revision. A number in parentheses indicates the year of last reapproval. A superscript epsilon ( $\epsilon$ ) indicates an editorial change since the last revision or reapproval.

## 1. Scope

1.1 This test method covers the procedure for determining the shear and bending fatigue performance of calcium phosphate coatings and of porous and nonporous metallic coatings and for determining the bending fatigue performance of metallic coatings oversprayed with calcium phosphate. This test method has been established based on plasma-sprayed titanium and plasma-sprayed hydroxylapatite coatings. The efficacy of this test method for other coatings has not been established. In the shear fatigue mode, this test method evaluates the adhesive and cohesive properties of the coating on a metallic substrate. In the bending fatigue mode, this test method evaluates both the adhesion of the coating as well as the effects that the coating may have on the substrate material. These methods are limited to testing in air at ambient temperature. These test methods are not intended for application in fatigue tests of components or devices; however, the test method which most closely replicates the actual loading configuration is preferred.

1.2 The values stated in SI units are to be regarded as the standard.

1.3 *This standard does not purport to address all of the safety concerns, if any, associated with its use. It is the responsibility of the user of this standard to establish appropriate safety and health practices and determine the applicability of regulatory limitations prior to use.*

## 2. Referenced Documents

2.1 *ASTM Standards:*<sup>2</sup>

**E6 Terminology Relating to Methods of Mechanical Testing**  
**E206 Definitions of Terms Relating to Fatigue Testing and**

**the Statistical Analysis of Fatigue Data**<sup>3</sup>

**E466 Practice for Conducting Force Controlled Constant Amplitude Axial Fatigue Tests of Metallic Materials**

**E467 Practice for Verification of Constant Amplitude Dynamic Forces in an Axial Fatigue Testing System**

**E468 Practice for Presentation of Constant Amplitude Fatigue Test Results for Metallic Materials**

**E1012 Practice for Verification of Test Frame and Specimen Alignment Under Tensile and Compressive Axial Force Application**

## 3. Definitions

3.1 The definitions of terms relating to shear and fatigue testing appearing in Terminology **E6** shall be considered as applying to the terms used in this test method.

## 4. Summary of Test Method

4.1 *Shear Fatigue Testing:*

4.1.1 The intent of the shear fatigue test is to determine the adhesive or cohesive strength, or both, of the coating.

4.1.2 This test method is designed to allow the coating to fail at either the coating/substrate interface, within the coating, or at the glue/coating interface between the coating and the adhesive bonding agent used to transmit the load to the coating.

4.2 *Bending Fatigue Testing:*

4.2.1 The primary intent of the bending fatigue test is to quantify the effect that the coating has on the substrate it is applied to. Secondly, it may be used to provide a subjective evaluation of coating adhesion, (that is, spalling resistance, cracking resistance, and so forth).

4.2.2 This test method is designed to first provide a substrate fatigue strength to serve as a baseline to assess the effects of the coating on the resulting fatigue strength of the system.

## 5. Significance and Use

5.1 The shear and bending fatigue tests are used to determine the effect of variations in material, geometry, surface condition, stress, and so forth, on the fatigue resistance of coated metallic materials subjected to direct stress for up to 10<sup>7</sup>

<sup>1</sup> This test method is under the jurisdiction of ASTM Committee **F04** on Medical and Surgical Materials and Devices and is the direct responsibility of Subcommittee **F04.15** on Materials Test Methods.

Current edition approved April 1, 2005. Published April 2005. Originally approved in 1991. Last previous edition approved in 2000 as F1160 – 00<sup>ε1</sup>. DOI: 10.1520/F1160-05.

<sup>2</sup> For referenced ASTM standards, visit the ASTM website, www.astm.org, or contact ASTM Customer Service at service@astm.org. For *Annual Book of ASTM Standards* volume information, refer to the standard's Document Summary page on the ASTM website.

<sup>3</sup> Withdrawn.

cycles. These tests may be used as a relative guide to the selection of coated materials for service under condition of repeated stress.

5.2 In order that such basic fatigue data be comparable, reproducible, and can be correlated among laboratories, it is essential that uniform fatigue practices be established.

5.3 The results of the fatigue test may be used for basic material property design. Actual components should not be tested using these test methods.

**6. Equipment Characteristics**

6.1 Equipment characteristics shall be in accordance with Practice E466, Section 7. See also Practices E467 and E1012 and Definitions E206.

6.2 *Shear Fatigue Test Grips:*

6.2.1 *General*—Various types of grips may be used to transmit the load to the specimens by the testing machine. To ensure axial shear stress, it is important that the specimen axis coincide with the centerline of the heads of the testing machine and that the coating test plane be parallel to the axial load. Any departure from this requirement (that is, any eccentric loading) will introduce bending stresses that are not included in the usual stress calculation (force/cross-sectional area).

6.2.2 A drawing of a typical gripping device for the test assembly is shown in Fig. 1.

6.2.3 Fig. 2 shows a drawing of the adaptor to mate the shear fixture to the tensile machine

6.2.4 Figs. 3 and 4 show a schematics of the test setup.

6.3 *Bending Fatigue Test Grips*—There are a variety of testing machines that may be employed for this test (that is, rotating beam fatigue machines and axial fatigue machines). The gripping method for each type of equipment shall be determined by either the manufacturer of that equipment (rotating beam machines) or the user.

**7. Adhesive Bonding Materials**

7.1 *Adhesive Bonding Agent*—A polymeric adhesive bonding agent in film form, or filled viscous adhesive cement, shall be identified and shall meet the following requirements.

7.1.1 The bonding agent shall be capable of bonding the coating on the test specimen components with an adhesive

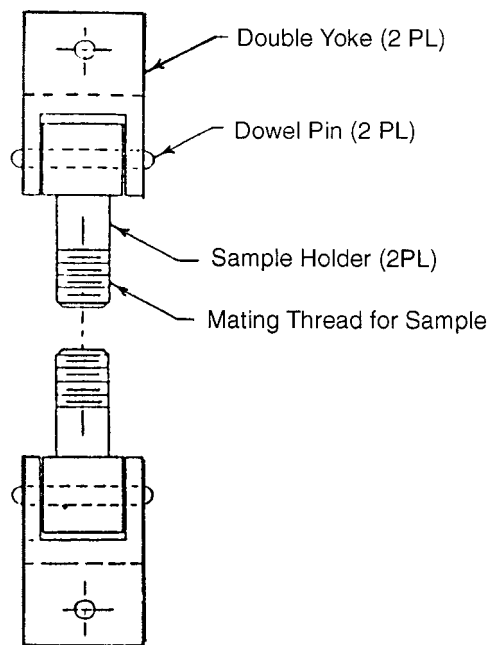

FIG. 2 Adaptor to Mate the Gripping Device to the Tensile Machine

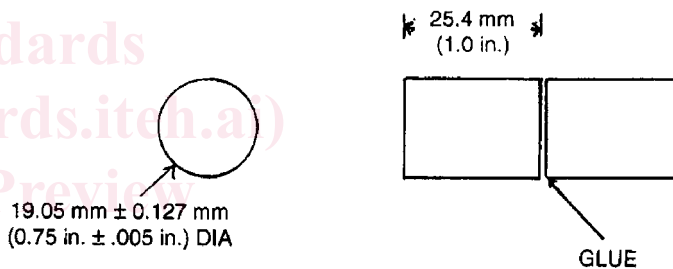

FIG. 3 Schematic of the Shear Test Setup

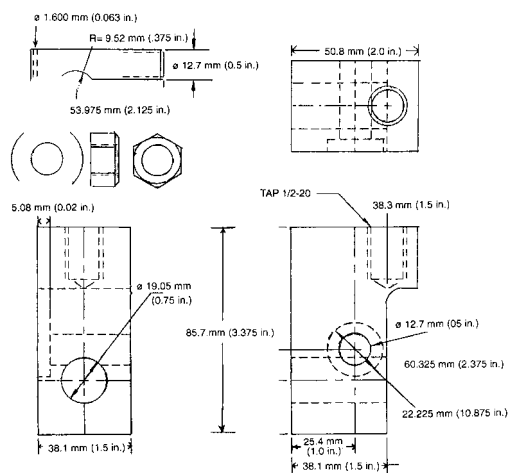

FIG. 1 Gripping Device for Shear Testing

shear strength that is at least 34.5 MPa (5000 psi) or as great as the minimum required adhesion or cohesion strength of the coating, whichever is greater.

7.1.2 In instances where coating porosity extends to the coating/substrate interface, the bonding agent shall be sufficiently viscous and application to the coating sufficiently detailed, to ensure that it will not penetrate through the coating to the substrate. The FM 1000 Adhesive Film<sup>4</sup> with a thickness of 0.25 mm (0.01 in.) has proven satisfactory for this test method.

7.1.3 If a material other than FM 1000 is used, or the condition of the FM 1000 is unknown, it must be tested to establish its equivalence to fresh FM 1000. Testing should be performed without the presence of the coating to establish the performance of the adhesive.

<sup>4</sup> The sole source of supply of the apparatus known to the committee at this time is Cytec Engineered Materials, Inc., 1300 Revolution St., Havre de Grace, MD 21078. If you are aware of alternative suppliers, please provide this information to ASTM International Headquarters. Your comments will receive careful consideration at a meeting of the responsible technical committee,<sup>1</sup> which you may attend.

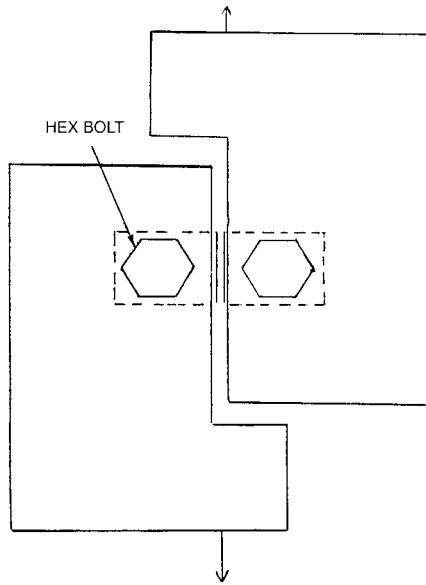

FIG. 4 Drawing of the Recommended Shear Test Specimen Assembly

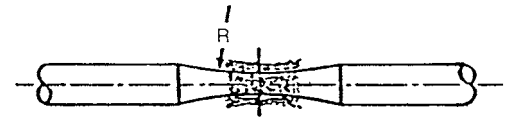

FIG. 6 Specimens With a Continuous Radius Between the Ends for Rotating Beam or Axial loading

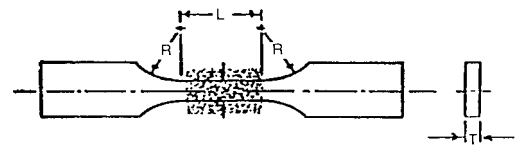

FIG. 7 Specimens With Tangentially Blending Fillets Between the Uniform Test Section and the Ends for Axial Loading

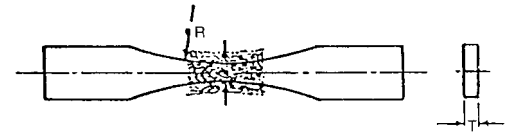

FIG. 8 Specimens With a Continuous Radius Between the Ends for Axial Loading

## 8. Test Specimen

### 8.1 Shear Fatigue Specimen for Calcium Phosphate and Metallic Coatings Only:

8.1.1 The recommended shear test specimen and setup is illustrated in Figs. 3 and 4, respectively. A complete assembled test assembly consists of two solid pieces, one with a coated surface and the other with an uncoated surface. The uncoated surface may be roughened to aid in the adhesion of the adhesive bonding agent.

8.1.2 The cross-sectional area of the substrate upon which the coating is applied shall be a nominal 2.85 cm<sup>2</sup> (0.44 in.<sup>2</sup>). When specimens of another cross-sectional area are used, the data must be demonstrated to be equivalent to the results produced using the 2.85-cm<sup>2</sup> standard cross-sectional area and the specimen size should be reported.

### 8.2 Bending Fatigue Specimen for Calcium Phosphate, Metallic, and Calcium Phosphate-Metallic Composite Coatings:

8.2.1 The type of specimen used will depend upon the objective of the test program, the type of equipment, the equipment capacity, and the form in which the material is available. However, the design must meet certain general criteria as follows:

8.2.1.1 The design of the specimen should be such that if specimen failure should occur, it should occur in the test section (reduced area as shown in Figs. 5-8).

8.2.1.2 Specimens using a flat tapered beam configuration should be designed such that a constant surface stress exists in the test section when the specimen is constrained at one end and point loaded perpendicular to the beam axis at the other end (that is, cantilever loading).

8.2.1.3 Rotating beam specimens may have unique dimensions, depending upon the type of machine used. Appropriate manufacturers' specifications for these specimens should be used.

### 8.3 Specimen Coating Preparation:

8.3.1 Coatings may be applied by any one of a number of techniques. All test specimens for coating characterization shall be prepared from indicative coating lots, using production feedstock lots and be coated on the same equipment used for actual implants. The coating should consist of a layer which is mechanically or chemically attached and covers the surface.

8.3.2 Coatings should be applied as follows:

8.3.2.1 For the shear fatigue specimens, the coating should be applied to the 19.05-mm (0.75-in.) diameter face only (see Fig. 3).

8.3.2.2 For the bending fatigue specimens, the coating should be applied to the reduced section only, with the exception of the constant stress specimen which should have coating in the entire region of constant stress (see Figs. 5-9).

8.3.3 All thermal treatments normally performed on the devices should be performed on the test specimens.

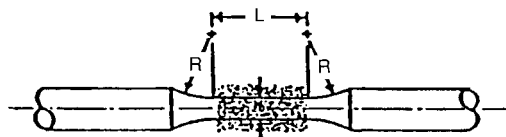

FIG. 5 Bending Fatigue Specimen With Tangentially Blending Fillets Between the Test Section and the Ends for Rotating Beam or Axial Loading

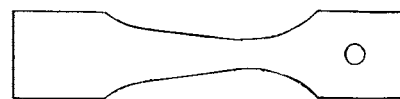

FIG. 9 Tapered Beam Configuration for Bend Testing

8.3.4 If used, passivation and sterilization techniques should be consistent with those used for actual devices.

8.3.5 *Inspection*—Before testing, visual inspections should be performed on 100 % of the test specimens. Non-uniform coating density shall be cause for specimen rejection. For the shear fatigue specimen, lack of coating on the coated face shall be cause for specimen rejection. For the bending fatigue specimen, lack of coating in highly stressed regions shall be cause for specimen rejection.

## 9. Procedure

9.1 The number of specimens required for testing, as well as the test methods in which the fatigue data may be interpreted, can vary. Several test methods are referenced in this test method.<sup>5,6,7</sup>

9.2 The type of specimen used will depend upon the objective of the test program, the type of equipment available, the equipment capacity, and the form in which the material is available. The specimen chosen should come as close to matching the intended application as possible.

9.3 The test frequency used shall not exceed 170 Hz.

### 9.4 *Shear Fatigue Specimens:*

9.4.1 *Curing the Adhesive*—The test results achieved are greatly dependent upon the adhesive used and the way in which it is cured. One suggested adhesive is FM 1000 having a thickness of 0.25 mm (0.01 in.). This material has successfully been cured using the following cycle:

9.4.1.1 Align the adhesive with the surface of the coating, taking precautions to align the adhesive in the center of the coating.

9.4.1.2 Apply a constant force using a calibrated high temperature spring, resulting in a stress of 0.138 MPa (20 psi) between the coating and the opposing device that will test the coating.

9.4.1.2.1 Care must be taken to maintain alignment of the coating and the matching counterface during the test.

9.4.1.3 Place the assembly in an oven and heat at 176°C for 2–3 h.

9.4.1.3.1 The exact amount of time necessary to cure the adhesive will need to be determined by each user, as oven temperature may vary with load size and oven type. It is suggested that the curing cycle be optimized first without the coating present.

9.4.1.4 Remove the cured assembly from the oven and allow it to cool to room temperature.

9.4.1.5 Remove all excess adhesive which has protruded from the coated surface. This process must not compromise the integrity of the sample.

9.4.2 Place the specimen assembly in the grips so that the long axis of the specimen is perpendicular to the direction of the applied shear load through the centerline of the grip assembly (see Fig. 3).

<sup>5</sup> Collins, J.A., *Failure of Materials in Mechanical Design*, John Wiley & Sons, New York, 1981.

<sup>6</sup> *Handbook of Fatigue Testing*, ASTM STP 566, ASTM, 1974.

<sup>7</sup> Frost, N. C., Marsh, K. J., and Pook, C. P., *Metal Fatigue*, Oxford University Press, London, 1974.

9.4.3 Specimens for which the adhesive has penetrated to the substrate shall be discarded and the results not included in the analysis and report.

### 9.5 *Bending Fatigue Specimens:*

9.5.1 Appropriate testing of the uncoated substrate material, upon which the coating will be applied, should be performed to establish a baseline from which to assess the effect of the coating.

9.5.1.1 The baseline test specimens may or may not be grit-blasted depending upon the objective of the test. In either event, the surface roughness should be reported.

9.5.1.2 For composite calcium phosphate-metallic coatings, additional baseline testing of specimens with only the metallic coating should also be performed to allow an assessment of the effects of each coating.

9.5.2 When mounting the specimen, alignment is crucial. Factors such as poorly machined specimens and misalignment of machine parts might result in excessive vibration leading to erroneous results.

9.5.3 For the rotating beam test, do not apply the load until the machine is operating at the frequency desired for testing.

9.5.4 For the purpose of calculating the applied loads on the test specimen, to determine the applied stresses, measure the dimensions from which the substrate area is calculated to the nearest 0.03 mm (0.001 in.) for dimensions equal to or greater than 5.08 mm (0.200 in.) and to the nearest 0.013 mm (0.0005 in.) for dimensions less than 5.08 mm (0.002 in.).

9.5.4.1 For the coated specimens, the uncoated substrate dimensions should be used to calculate the applied stress.

9.5.5 Any fracture which occurs outside the gage section shall be rejected.

## 10. Test Termination

10.1 Continue the testing until the specimen fails or until a predetermined number of cycles has been reached (typically  $10^7$  cycles). Failure may be defined as: (1) complete separation of the coating, (2) visible cracking at a specified magnification, (3) a crack of certain dimensions, (4) or by some other criterion.

## 11. Stress Calculation

11.1 *Shear Fatigue Specimens*—Calculate the substrate area upon which the coating is applied to the nearest 0.06 cm<sup>2</sup> (0.01 in.<sup>2</sup>). Record peak (failure) load and calculate failing stress in megapascals (pound-force per square inch) of adhesive area as follows:

$$S = F/A \quad (1)$$

where:

$S$  = adhesion or cohesion strength,

$F$  = maximum load to failure, and

$A$  = cross-sectional area.

11.2 *Bending Fatigue Specimens*—For the purpose of calculating the applied loads on the test specimen to determine the applied stresses, measure the dimensions from which the substrate adhesive area is calculated to the nearest 0.03 mm (0.001 in.) for dimensions equal to or greater than 5.08 mm (0.200 in.) and to the nearest 0.013 mm (0.0005 in.) for dimensions less than 5.08 mm (0.002 in.).