

INTERNATIONAL STANDARD

ISO
182-1

First edition
1990-12-15

**Plastics — Determination of the tendency of
compounds and products based on vinyl chloride
homopolymers and copolymers to evolve
hydrogen chloride and any other acidic products
at elevated temperatures —**

Part 1:

Congo red method

<https://standards.iteh.ai/catalog/standards/sist/d67e3d08-cbde-4ee4-92b1-f2a058797275/iso-182-1-1990>

*Plastiques — Détermination de la tendance des compositions à base
d'homopolymères et copolymères du chlorure de vinyle à dégager du
chlorure d'hydrogène et éventuellement d'autres produits acides à
températures élevées —*

Partie 1: Méthode au rouge Congo

INTERNATIONAL

ISO



Reference number
ISO 182-1:1990(E)

Foreword

ISO (the International Organization for Standardization) is a worldwide federation of national standards bodies (ISO member bodies). The work of preparing International Standards is normally carried out through ISO technical committees. Each member body interested in a subject for which a technical committee has been established has the right to be represented on that committee. International organizations, governmental and non-governmental, in liaison with ISO, also take part in the work. ISO collaborates closely with the International Electrotechnical Commission (IEC) on all matters of electrotechnical standardization.

Draft International Standards adopted by the technical committees are circulated to the member bodies for voting. Publication as an International Standard requires approval by at least 75 % of the member bodies casting a vote.

International Standard ISO 182-1 was prepared by Technical Committee ISO/TC 61, *Plastics*.

Together with ISO 182-2, it cancels and replaces ISO Recommendation R 182:1970, of which these two parts of ISO 182 constitute a technical revision.

ISO 182 consists of the following parts, under the general title *Plastics — Determination of the tendency of compounds and products based on vinyl chloride homopolymers and copolymers to evolve hydrogen chloride and any other acidic products at elevated temperatures*:

- Part 1: Congo red method
- Part 2: pH method
- Part 3: Conductometric method
- Part 4: Potentiometric method

© ISO 1990

All rights reserved. No part of this publication may be reproduced or utilized in any form or by any means, electronic or mechanical, including photocopying and microfilm, without permission in writing from the publisher.

International Organization for Standardization
Case Postale 56 • CH-1211 Genève 20 • Switzerland

Printed in Switzerland

Plastics — Determination of the tendency of compounds and products based on vinyl chloride homopolymers and copolymers to evolve hydrogen chloride and any other acidic products at elevated temperatures —

Part 1:

Congo red method

WARNING — The use of this part of ISO 182 may involve hazardous materials, operations and equipment. This part of ISO 182 does not purport to address all of the safety problems associated with its use. It is the responsibility of the user of this part of ISO 182 to establish appropriate safety and health practices and determine the applicability of regulatory limitations prior to use.

ISO 182-1:1990

<https://standards.iteh.ai/catalog/standards/sist/d67e3d08-cbde-4ee4-92b1-f2a058797275/iso-182-1-1990>

1 Scope

1.1 This part of ISO 182 specifies a method for the determination of the thermal stability at elevated temperature of compounds and products based on vinyl chloride homopolymers and copolymers (in the following text abbreviated to PVC) which undergo dehydrochlorination (the evolution of hydrogen chloride).

1.2 The method is intended primarily as a simple and rapid quality-control test during the manufacture and conversion of PVC compounds. It may be used also for the characterization of PVC compounds and products.

It is suitable for coloured compounds and products where a discolouration test under the action of heat may be unsatisfactory.

1.3 The method is recommended for compounded materials and products only. It is not recommended for compounds in the form of dry blends since such materials may not be sufficiently homogeneous.

PVC compounds and products may evolve decomposition products in addition to hydrogen chlor-

ide at elevated temperatures. A limited number of these decomposition products may affect the time to colour change of the indicator paper. It is not possible to compensate for this effect within the scope of this part of ISO 182, and therefore care is necessary in comparing results for dissimilar compounds and products.

2 Normative references

The following standards contain provisions which, through reference in this text, constitute provisions of this part of ISO 182. At the time of publication, the editions indicated were valid. All standards are subject to revision, and parties to agreements based on this part of ISO 182 are encouraged to investigate the possibility of applying the most recent editions of the standards indicated below. Members of IEC and ISO maintain registers of currently valid International Standards.

ISO 565:1990, *Test sieves — Metal wire cloth, perforated metal plate and electroformed sheet — Nominal sizes of openings.*

ISO 3696:1987, *Water for analytical laboratory use — Specification and test methods.*

3 Principle

A test portion of the PVC compound or product is maintained at an agreed temperature in still air until the colour of a Congo red paper held above it changes from red to blue. If universal indicator paper is used, the relevant colour change is that corresponding to pH 3. The time required for the colour change is taken to be the stability time, t_s .

4 Reagents

4.1 Congo red indicator paper.

Commercial Congo red paper is suitable, providing that it is available in 10 mm width.

The paper may also be prepared by immersing strips of filter paper, 10 mm wide, in a 0,15 % (m/m) solution of Congo red in methanol, and drying.

4.2 Universal indicator paper, in roll form, with a pH range of 1 to 10, shall be used. The paper shall be provided with a colour scale in order to interpret the changes in pH.

5 Apparatus

5.1 Test tubes, with the following dimensions:

external diameter: approximately 17 mm

wall thickness: approximately 0,4 mm

length, minimum: 150 mm

Stoppers are required with holes through the centres which provide an interference fit for the glass tubes (5.2). The complete arrangement is shown in figure 1.

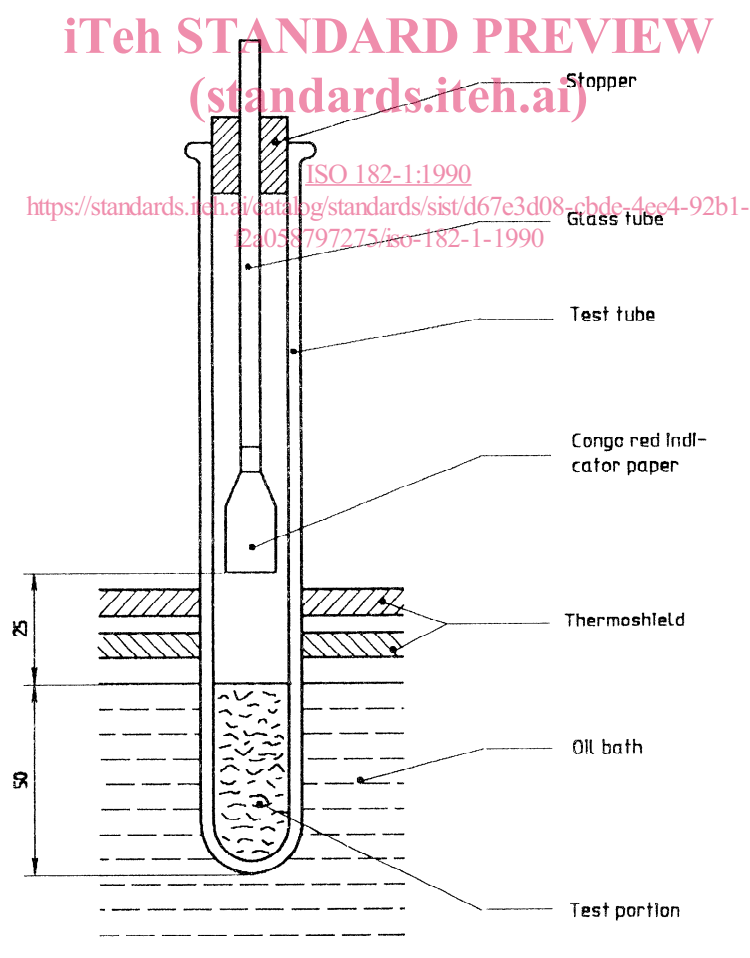

Figure 1 — Arrangement of the test tube in the oil bath

5.2 Small glass tubes, 2 mm to 3 mm in internal diameter and approximately 100 mm long (see figure 1).

5.3 Oil bath, with a capacity of at least 10 litres. The bath shall be capable of operating in the temperature range 170 °C to 210 °C and of maintaining the test temperature with an accuracy of $\pm 0,5$ °C throughout the working volume.

5.4 Heat-resistant insulating shield, drilled to permit the insertion of test tubes (5.1) and positioned to permit the suspension of the tubes in the hot oil bath (5.3) to a depth of approximately 50 mm.

5.5 Thermometer, provided with a scale convenient for reading the oil bath temperature in the range 170 °C to 210 °C and with a scale division of 0,1 °C.

5.6 Stopclocks, two or four stopclocks are required, depending on the parameters to be measured (see 9.6).

6 Preparation of test portions

The measured stability times depend to some extent on the surface area of the prepared test portions as well as on their thermal history. Any cutting or grinding of a material necessary to produce the test portions shall be carried out in a uniform manner. Heating of the material during grinding shall be avoided.

6.1 PVC plastisols

Spread these materials on glass plates and gel in an oven at an agreed temperature so that sheets 0,5 mm thick are formed. Cut these sheets into squares with sides approximately 2 mm long.

6.2 PVC pellets, extrudates, mouldings, thick sheet, etc.

Cut or grind these materials so that more than 80 % of the material passes through a 2,0 mm sieve (ISO 565, R 20/3 series) and an adequate amount is retained on a 1,4 mm sieve to prepare the test portions.

6.3 PVC film and sheet

Cut these materials into squares or cubes with sides no longer than 2 mm.

6.4 PVC coatings

Separate these materials from the substrate and then treat as in 6.2 or 6.3.

6.5 Insulation or sheathing of cables and conductors

Cut thin slivers with the dimensions indicated in 6.2.

7 Number of tests

For each sample, conduct at least two determinations, using two separate test tubes which are immersed in the oil bath at the same time.

8 Temperatures for dehydrochlorination

These are preferably:

200 °C for unplasticized compounds and products;

200 °C for compounds and products for cable insulation and sheathing;

180 °C for other plasticized compounds and products.

9 Procedure

9.1 Place a quantity of the PVC material to be tested, prepared in accordance with the appropriate part of clause 6, in a test tube (5.1) such that the tube is filled to a depth of about 50 mm. Fill a second test tube (5.1) in the same way. Shake each tube gently, taking care that the pieces do not form a compact mass or adhere to the walls of the test tube.

9.2 Preheat the oil bath (5.3) to near the agreed test temperature, and adjust to the exact test temperature as indicated by the thermometer (5.5).

9.3 For each test tube, cut out or select a strip of the chosen indicator paper (4.1 or 4.2) 30 mm long and 10 mm wide. Roll or fold one end of the indicator paper strip and insert it into the glass tube (5.2). Wet the indicator strip with grade 2 water as defined in ISO 3696. Insert the glass tube into the stopper. Slide the glass tube into the test tube, close the test tube with the stopper and adjust the position of the glass tube in the stopper so that the lower edge of the paper is located 25 mm above the top of the test portion.

9.4 Immerse each test tube in the oil bath to the level of the upper surface of the test sample, starting a stopclock (5.6) for each test tube.

9.5 Stop the stopclock for each of the test determinations when there is the first clear sign of a change from red to blue in the Congo red indicator paper. When using universal indicator paper, the end point shall correspond to the colour indicating pH 3.

9.6 When certain stabilizers are used in the PVC composition, the colour change is slow and not very distinct. In this case, when using Congo red indicator paper, record two different times, corresponding to the first sign of colour change from red to violet and then the permanent change from violet to blue.

Four stopclocks are required to conduct the test in these circumstances.

10 Expression of results

Record the time(s), in minutes, for each of the two determinations. The arithmetic mean of these values is the stability time t_s .

When two values differ by more than $\pm 10\%$ from the mean, the results shall be discarded and the test repeated.

11 Precision

The precision of this test method is not known because inter-laboratory data are not available. This method is not for use in specifications or in the case

of disputed results as long as these data are not available.

12 Test report

The test report shall include the following information:

- a) a reference to this part of ISO 182;
- b) the nature, form and designation of the PVC product sample;
- c) if appropriate, the manufacturer, where sampled and the degree of comminution of the specimen;
- d) the test temperature;
- e) the stability time t_s , in minutes, to the nearest half-minute (include the individual values and the arithmetic mean);
- f) in the case of slow colour changes in the indicator paper, the two times recorded in 9.6 (again, include the individual values and the arithmetic mean);
- g) the date of the test.

ITeH STANDARD PREVIEW
(standards.iteh.ai)

ISO 182-1:1990

<https://standards.iteh.ai/catalog/standards/sist/d67e3d08-cbde-4ee4-92b1->

[2a058797275/iso-182-1-1990](https://standards.iteh.ai/catalog/standards/sist/d67e3d08-cbde-4ee4-92b1-2a058797275/iso-182-1-1990)

iTeh STANDARD PREVIEW
(standards.iteh.ai)

This page intentionally left blank

ISO 182-1:1990

<https://standards.iteh.ai/catalog/standards/sist/d67e3d08-cbde-4ee4-92b1-f2a058797275/iso-182-1-1990>

iTeh STANDARD PREVIEW
(standards.iteh.ai)

ISO 182-1:1990

<https://standards.iteh.ai/catalog/standards/sist/d67e3d08-cbde-4ee4-92b1-f2a058797275/iso-182-1-1990>

UDC 678.743.22:536.42:543.241

Descriptors: plastics, polyvinyl chloride, tests, thermal tests, high temperature tests, determination, thermal stability, pH-metry.

Price based on 4 pages
