

INTERNATIONAL STANDARD

ISO 182-4

First edition
1993-04-01

Plastics — Determination of the tendency of compounds and products based on vinyl chloride homopolymers and copolymers to evolve hydrogen chloride and any other acidic products at elevated temperatures —

Part 4: Potentiometric method

*Plastiques — Détermination de la tendance des compositions à base
d'homopolymères et copolymères du chlorure de vinyle à dégager du
chlorure d'hydrogène et éventuellement d'autres produits acides à
températures élevées —*

Partie 4: Méthode potentiométrique



Reference number
ISO 182-4:1993(E)

Foreword

ISO (the International Organization for Standardization) is a worldwide federation of national standards bodies (ISO member bodies). The work of preparing International Standards is normally carried out through ISO technical committees. Each member body interested in a subject for which a technical committee has been established has the right to be represented on that committee. International organizations, governmental and non-governmental, in liaison with ISO, also take part in the work. ISO collaborates closely with the International Electrotechnical Commission (IEC) on all matters of electrotechnical standardization.

Draft International Standards adopted by the technical committees are circulated to the member bodies for voting. Publication as an International Standard requires approval by at least 75 % of the member bodies casting a vote.

International Standard ISO 182-4 was prepared by Technical Committee ISO/TC 61, *Plastics*, Sub-Committee SC 6, *Ageing, chemical and environmental resistance*.

<https://standards.iteh.ai/catalog/standards/sist/20a22e82-9890-4464-8fc4->

Together with the three other parts of ISO 182, it cancels and replaces ISO Recommendation R 182:1970, of which the four parts of ISO 182 constitute a technical revision.

ISO 182 consists of the following parts, under the general title *Plastics — Determination of the tendency of compounds and products based on vinyl chloride homopolymers and copolymers to evolve hydrogen chloride and any other acidic products at elevated temperatures*:

- Part 1: Congo red method
- Part 2: pH method
- Part 3: Conductometric method
- Part 4: Potentiometric method

Annexes A and B of this part of ISO 182 are for information only.

© ISO 1993

All rights reserved. No part of this publication may be reproduced or utilized in any form or by any means, electronic or mechanical, including photocopying and microfilm, without permission in writing from the publisher.

International Organization for Standardization
Case Postale 56 • CH-1211 Genève 20 • Switzerland

Printed in Switzerland

Plastics — Determination of the tendency of compounds and products based on vinyl chloride homopolymers and copolymers to evolve hydrogen chloride and any other acidic products at elevated temperatures —

Part 4: Potentiometric method

iTeh STANDARD PREVIEW

WARNING — The use of this part of ISO 182 may involve hazardous materials, operations and equipment. This part of ISO 182 does not purport to address all of the safety problems associated with its use. It is the responsibility of the user of this part of ISO 182 to establish appropriate safety and health practices and determine the applicability of regulatory limitations prior to use.

<https://standards.iteh.ai/catalog/standards/sist/20a22e82-9890-4464-8fc4-905d3693a244/iso-182-4-1993>

1 Scope

1.1 This part of ISO 182 specifies a method for the determination of the thermal stability at elevated temperature of compounds and products based on vinyl chloride homopolymers and copolymers (in the following text abbreviated as PVC) which undergo dehydrochlorination (the evolution of hydrogen chloride).

1.2 The method may be used as a quality control test during manufacture and conversion of PVC compounds. It may also be used for the characterization of PVC compounds and products, especially with regard to the effectiveness of their heat-stabilizing systems.

It is suitable for coloured PVC compounds and products for which a discolouration test under the action of heat may be unsatisfactory.

1.3 The method is recommended for compounded PVC materials and products only, although it can be used for polymers in powder form under appropriate conditions to be agreed upon between the interested

parties. The method is not recommended for PVC compounds in the form of dry blends, since such materials may not be sufficiently homogeneous.

1.4 PVC compounds and products may evolve other decomposition products in addition to hydrogen chloride at elevated temperatures. A limited number of these products, originating from the decomposition of certain comonomers (such as vinyl esters of organic acids) or of plasticizers, stabilizers and other additives, may effect the pH or the conductivity of an aqueous solution when they are absorbed. Consequently, the results obtained for different products by the methods described in Parts 2 and 3 of ISO 182 may not be comparable with those obtained using the method described in the present part of ISO 182.

1.5 This part of ISO 182 specifies a potentiometric method for the determination of chloride ion (Cl^-) concentration (expressed as pCl) in an absorbing solution, independent of the presence of other ions. The value pCl is defined as $-\lg c_{\text{Cl}}$, where c_{Cl} is the molar concentration of chloride ions. This method is, therefore, particularly recommended for plasticized PVC compounds and copolymers.

1.6 This method may also be applied to other plastics materials that can evolve hydrogen chloride when heated under the conditions prescribed by the relevant specifications, or as agreed upon between the interested parties.

2 Normative references

The following standards contain provisions which, through reference in this text, constitute provisions of this part of ISO 182. At the time of publication, the editions indicated were valid. All standards are subject to revision, and parties to agreements based on this part of ISO 182 are encouraged to investigate the possibility of applying the most recent editions of the standards indicated below. Members of IEC and ISO maintain registers of currently valid International Standards.

ISO 182-2:1990, *Plastics — Determination of the tendency of compounds and products based on vinyl chloride homopolymers and copolymers to evolve hydrogen chloride and any other acidic products at elevated temperatures — Part 2: pH method.*

ISO 182-3:1993, *Plastics — Determination of the tendency of compounds and products based on vinyl chloride homopolymers and copolymers to evolve hydrogen chloride and any other acidic products at elevated temperatures — Part 3: Conductometric method.*

ISO 565:1990, *Test sieves — Metal wire cloth, perforated metal plate and electroformed sheet — Nominal sizes of openings.*

ISO 4793:1980, *Laboratory sintered (fritted) filters — Porosity grading, classification and designation.*

ISO 5725:1986, *Precision of test methods — Determination of repeatability and reproducibility for a standard test method by inter-laboratory tests.*

ISO 6353-2:1983, *Reagents for chemical analysis — Part 2: Specifications — First series.*

3 Definition

For the purposes of this part of ISO 182, the following definition applies.

3.1 stability time, t_s : Time, measured by reference to a predetermined change in the pCl of an absorbing solution, required for a certain amount of hydrogen chloride to be evolved when a prescribed mass of PVC compound or product is maintained at an elevated temperature under the test conditions specified in this part of ISO 182.

4 Principle

A test portion of the PVC compound or product is maintained at an agreed temperature in a nitrogen gas stream and the hydrogen chloride evolved is absorbed in a given amount of an appropriate solution. The amount of hydrogen chloride evolved is determined potentiometrically in relation to the recorded change in pCl of the absorbing solution.

5 Reagents

During the test, use only reagents of recognized analytical grade in accordance with ISO 6353-2.

5.1 Pure nitrogen, containing less than 6 ppm oxygen and less than 0,1 ppm carbon dioxide by volume. The purity shall be such that when the gas is passed through the absorbing solution for 1 h at a rate of 7,2 l/h \pm 0,1 l/h, the conductivity of the water remains unchanged.

The gas shall be dried by passing it through a suitable drying agent and the flow-rate through the dehydrochlorination cell adjusted by means of a needle valve and measured using a suitable flowmeter.

5.2 Hydrochloric acid, aqueous solution, $c(\text{HCl}) = 0,01 \text{ mol/l}$.

5.3 Distilled or demineralized water.

5.4 Potassium nitrate (KNO_3), potassium sulfate (K_2SO_4) or other salts, for the preparation of the absorbing solution (see 10.4).

6 Apparatus

The general arrangement of the apparatus, shown in figure 1, includes a re-usable dehydrochlorination cell A. This cell may be replaced by a disposable cell B.

6.1 Dehydrochlorination cells.

6.1.1 Cell A (re-usable), with shape and dimensions as shown in figure 2.

A recommended procedure for cleaning the cell is given in annex A.

6.1.2 Cell B (disposable), with shape and dimensions as shown in figure 3.

NOTE 1 Other types of cell may be employed if it has been proved that the results obtained are equivalent to those obtained with one of the cells described in 6.1.1 and 6.1.2.

6.2 Test portion holder, for use with cell A. The test portion is supported on a porous sintered-glass disc (grade P 100, see ISO 4793), 10 mm in diameter.

To prevent blocking of the porous disc, it is advisable to place a thin, soft layer of glass wool between it and the test portion.

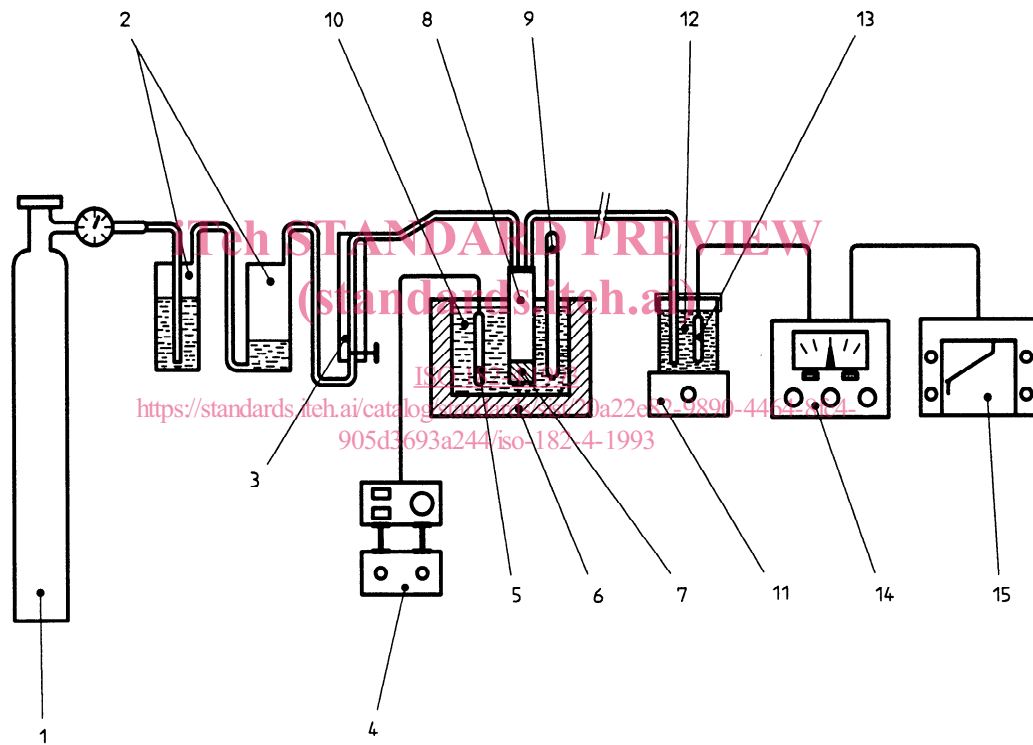

- | | |
|---|---------------------------------------|
| 1 N ₂ cylinder | 9 Thermometer (scale division 0,1 °C) |
| 2 Purification train | 10 Silicone oil |
| 3 Ball flowmeter | 11 Magnetic stirrer |
| 4 Electronic temperature controller (scale division 0,1 °C) | 12 Absorbing solution |
| 5 Temperature sensor | 13 Measuring electrode(s) |
| 6 Heating bath | 14 Potentiometer |
| 7 PVC test portion | 15 Recorder |
| 8 Dehydrochlorination cell | |

Figure 1 — General arrangement of apparatus

ITh STANDARD PREVIEW
(standards.iteh.ai)

Dimensions in millimetres

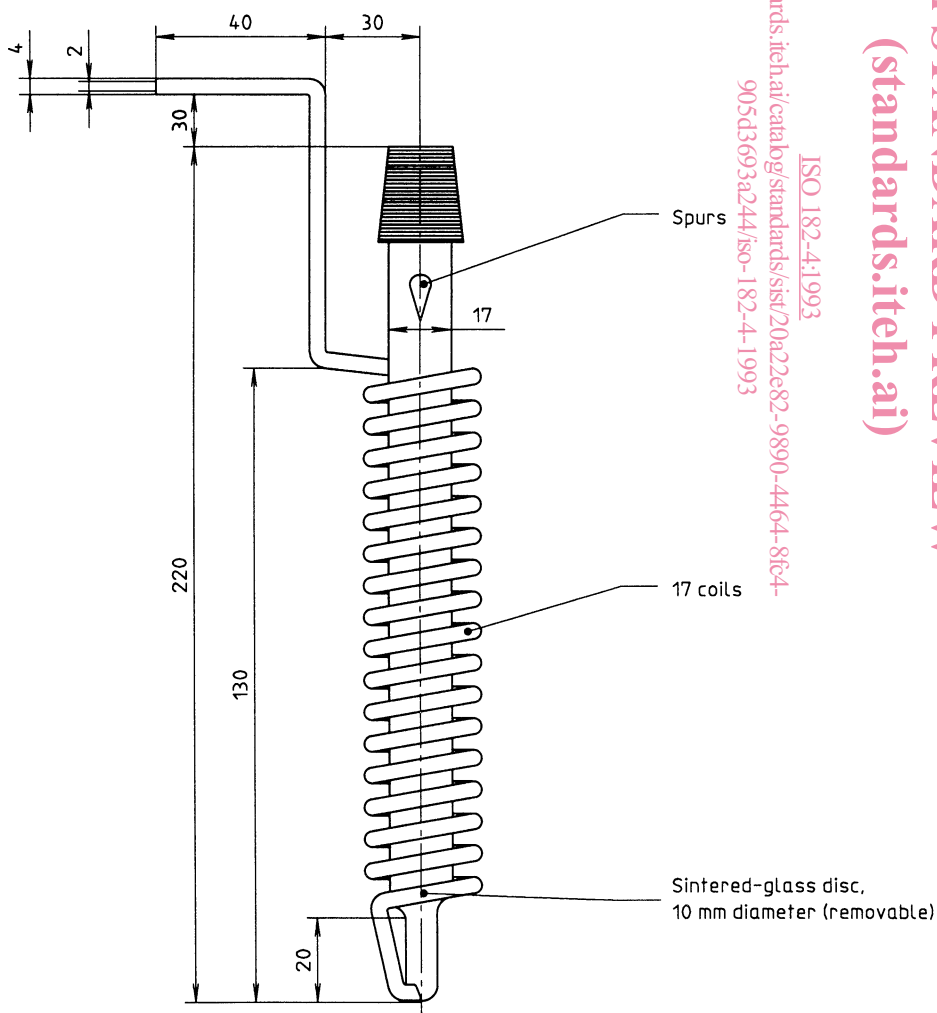

Figure 2 — Cell A (re-usable) for dehydrochlorination of PVC samples

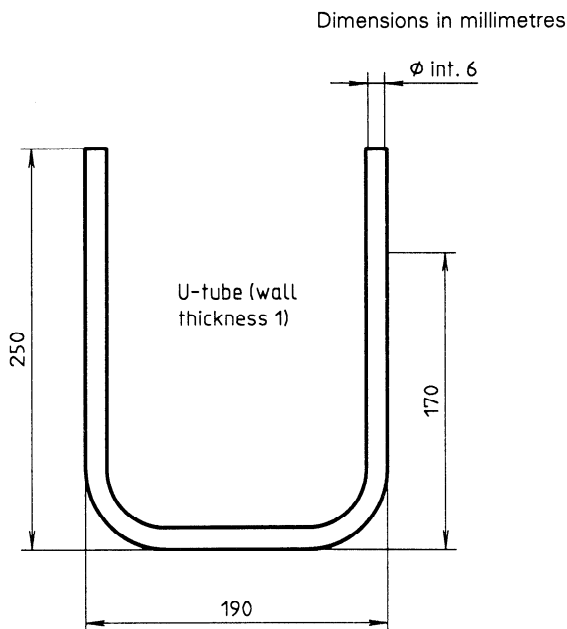

Figure 3 — Cell B (disposable) for dehydrochlorination of PVC samples

A recommended procedure for cleaning the disc support is given in annex A.

6.3 Glass connection tube, for use with cell A, having dimensions as shown in figure 4. The connection tube is secured to cell A by two springs fixed to hooks on the ground-glass joints. The tube shall be provided with an insulating jacket.

6.4 Expansion joints and cell connections, for use with cell B. Cell B is connected to the apparatus through flexible polytetrafluoroethylene (PTFE) and silicone rubber tubes. Special joints allow for thermal expansion. The complete joint arrangement is shown in figure 5.

6.5 Oil bath, with a capacity of at least 10 l. The bath shall be capable of operating in the temperature range 170 °C to 210 °C and of maintaining the test temperature with an accuracy of 0,1 °C.

The bath shall be designed in such a way that the temperature distribution is even throughout, and shall have a thermal capacity sufficient to avoid temperature change when the dehydrochlorination cell is immersed in it.

6.6 Thermometer, with a scale suitable for reading the heating bath temperature in the range 170 °C to 210 °C and with a scale division of 0,1 °C.

6.7 Balance, with a scale division of 1 mg.

6.8 Measurement cell

A suitable measurement cell is shown in figure 6. If the diameters of the measurement electrode and the feed tube for the gases from decomposition of the test portion are sufficiently small, a 400 ml Erlenmeyer flask is a suitable alternative measurement cell.

A recommended procedure for cleaning the cell is given in annex A.

6.9 Magnetic stirrer, capable of providing gentle agitation within the measurement cell.

6.10 Potentiometer, for the determination of the pCl.

6.10.1 Specific electrode for the Cl^- ions, having a precision of at least 0,01 pCl. The sensitive element is a silver chloride (AgCl) crystal (see annex B).

6.10.2 Reference electrode on the basis of calomel (mercurous chloride) ($\text{Hg}/\text{Hg}_2\text{Cl}_2/\text{saturated KCl}$) or of mercurous sulfate ($\text{Hg}/\text{Hg}_2\text{SO}_4/\text{saturated K}_2\text{SO}_4$) or other, according to the specifications of the supplier of the specific electrode.

6.10.3 Extension (salt bridge), for the reference electrode. For the measurement of Cl^- ions, a salt bridge is absolutely necessary if a mercurous chloride electrode is used.

NOTE 2 Some "combined" specific electrodes are commercially available which also include a reference electrode (see annex B).

6.10.4 Electronic millivoltmeter.

The apparatus shall be provided with a device for automatic temperature compensation and equipped with an output for a recording device.

6.11 Stopclock, or other suitable timing device, if not included in the recorder.

6.12 Flowmeter, for example a rotameter, or other suitable device capable of measuring a gas flow-rate within the range $120 \text{ cm}^3/\text{min} \pm 4 \text{ cm}^3/\text{min}$.

7 Preparation of test samples

The measured stability times t_s depend to some extent on the surface area of the prepared test portions as well as on their thermal history. Any cutting or grinding of a material necessary to produce the test portions shall be conducted in a uniform manner, avoiding heating of the material.

NOTE 3 Cryogenic grinding is recommended.

Dimensions in millimetres

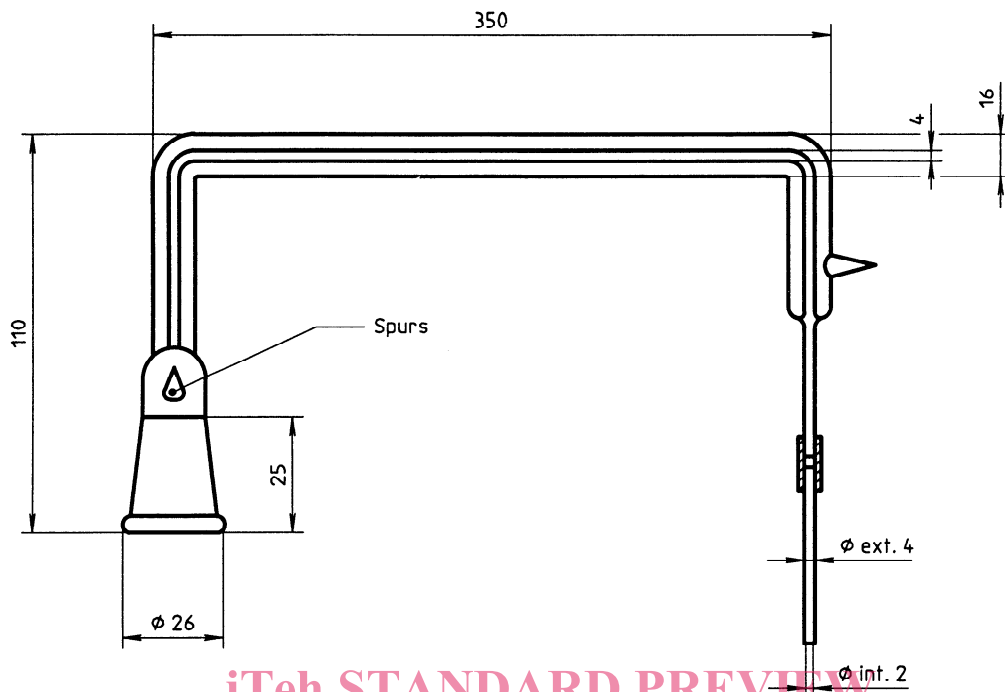

a) Glass tube for use with cell A

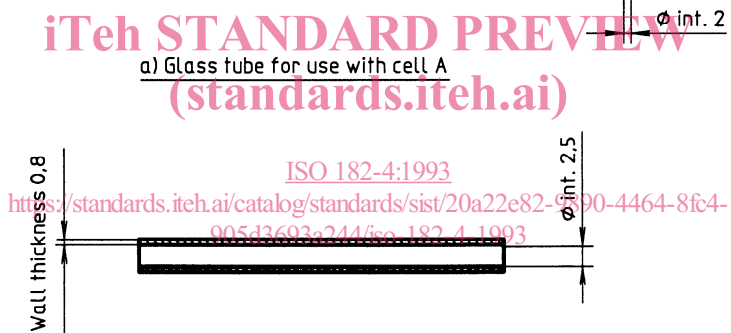

b) PTFE tubing for use with cell B

Figure 4 — Tubes for connecting the dehydrochlorination cell to the measurement cell

Dimensions in millimetres

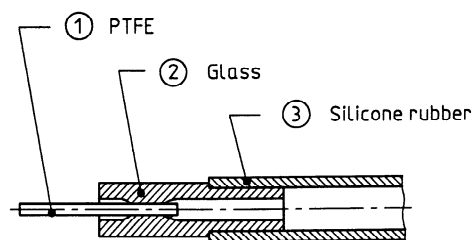

- 1 PTFE tube: ϕ ext. 4,1
 ϕ int. 2,5
- 2 Glass tube: ϕ ext. 8
 ϕ int. 6
- 3 Silicone rubber tube: ϕ ext. 12
 ϕ int. 6

Figure 5 — Expansion joint for connection on each side of cell B

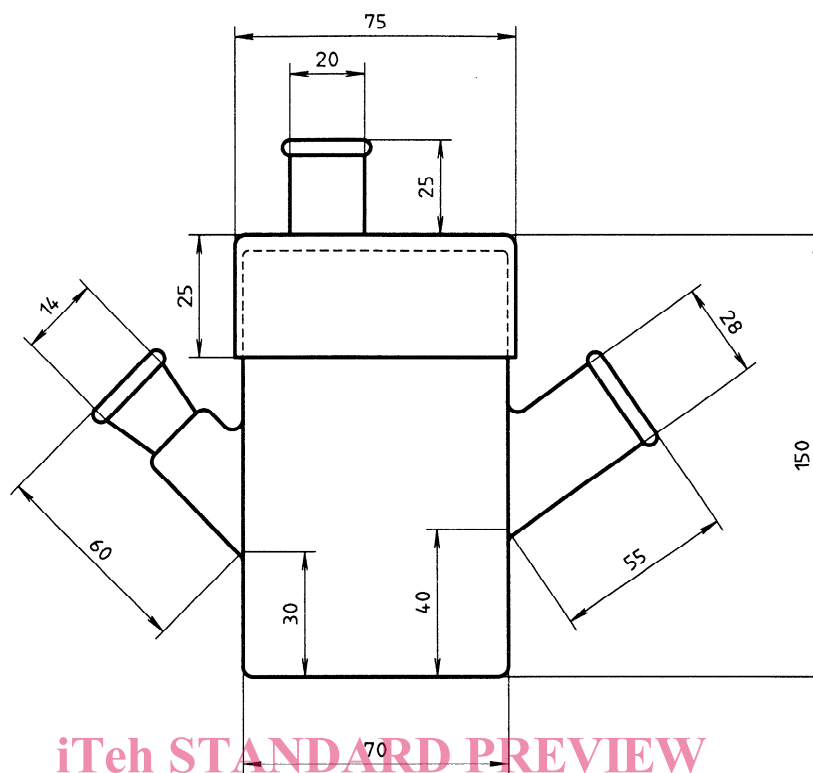

Figure 6 — Example of a suitable measurement cell

ISO 182-4:1993

7.1 PVC plastisols

<https://standards.iteh.ai/catalog/standards/sist/71522c0c-1100-4c64-8641-905d3693a244/iso-182-4:1993>

Spread these materials on glass plates and gel them in an oven at an agreed temperature and time, so that sheets 0,5 mm thick are formed. Cut these sheets into squares approximately 2 mm on a side.

7.2 PVC pellets, extrudates, mouldings, thick sheet, etc.

Cut or grind these materials so that more than 80 % of the material passes through a 2 mm sieve (ISO 565, R 20/3 series) and an amount adequate to prepare the test portions is retained on a 1,4 mm sieve.

7.3 PVC film and sheet

Cut these materials into squares or cubes having sides no longer than 2 mm.

7.4 PVC coatings

Separate these materials from the substrate and then treat as in 7.2 or 7.3.

7.5 Cable and conductor insulation or sheathing

Cut thin slivers of the dimensions indicated in 7.2.

8 Number of tests

Conduct at least two determinations on each sample.

9 Temperatures for dehydrochlorination

The test temperatures are preferably

200 °C for unplasticized compounds and products;

200 °C for electric and fibre-optic insulation and sheathing materials and products;

180 °C to 200 °C for plasticized compounds and products, depending on their stabilization.

10 Test procedure

10.1 Preparation of test portion

Weigh, to the nearest 0,01 g, 2 g of the test sample, prepared in accordance with the appropriate part of clause 7.

Introduce this test portion into the chosen dehydrochlorination cell (6.1) and connect the cell to the remainder of the apparatus, taking particular care to ensure that all joints are tightly closed and, where appropriate, that all ground-glass joints are sealed with a suitable stopcock grease.

10.2 Preliminary operations

Heat the oil bath (6.5) to the agreed test temperature. Start the flow of nitrogen through the dehydrochlorination cell, adjust to a flow-rate of $120 \text{ cm}^3/\text{min} \pm 4 \text{ cm}^3/\text{min}$ and flush the cell for about 5 min to eliminate air. During this period the dehydrochlorination cell shall not be heated. The nitrogen flowing through the cell shall be allowed to escape to the atmosphere without passing through the absorbing liquid contained in the measurement cell.

10.3 Special precautions when using dehydrochlorination cell A

When using cell A (6.1.1) all spirals of the preheating tube shall be completely immersed in the oil bath. The end of the gas-outlet tube shall be positioned about 5 mm from the bottom of the measurement cell.

10.4 Preparation of the measurement cell

Prepare an aqueous solution (support electrolyte) having the ionic strength and the pH as specified by the supplier of the specific electrode (see examples in annex B) in relation to the concentration range of the Cl^- ions to be measured.

Introduce 180 ml of the support electrolyte into the measurement cell and start the stirrer. Allow the cell to reach thermal equilibrium in the range of $23 \text{ }^\circ\text{C} \pm 2 \text{ }^\circ\text{C}$ (or in a narrower range if specified by the supplier of the electrode) and maintain it at that temperature.

Introduce the specific electrode (6.10.1) and the reference electrode (6.10.2) with its salt bridge filled with the support electrolyte, and connect them to the recording millivoltmeter (6.10.4).

NOTES

4 Some specific electrodes are sensitive to temperature and also to light. For this reason it is desirable to work under a constant illumination.

5 To maintain a constant temperature it may be necessary to surround the measuring cell with a thermostatted water bath.

10.5 Calibration of the potentiometer

First, calibrate the specific electrode by measuring the potential (in millivolts) for different known concen-

trations of chloride ion (Cl^-). The standard solutions shall have the same ionic strength as the support electrolyte.

Prepare at least four standard solutions having different concentrations of Cl^- ions over the range of pCl measurement, e.g. 10^{-3} mol/l , 10^{-4} mol/l , 10^{-5} mol/l and 10^{-7} mol/l .

Measure the potentials of the four standard solutions and plot the graph

$$E = f(\lg c_{\text{Cl}})$$

where

E is the potential, in millivolts;

c_{Cl} is the amount-of-substance concentration of Cl^- ions, in moles per litre, in the support electrolyte.

NOTES

6 The amount-of-substance concentration of the Cl^- ions corresponding to a pCl of 3,8 according to the equation

$$\text{pCl} = \lg c_{\text{Cl}}$$

is $1,585 \times 10^{-4} \text{ mol/l}$.

7 The potential is really a function of the activity of the ions, not of their concentration. However this difference is cancelled if the calibration and the measurement are conducted in dilute solutions having the same ionic strengths.

10.6 Decomposition of the test portion and measurement of the pCl

Immerse the dehydrochlorination cell rapidly in the oil bath and immediately place the end of the connecting tube into the electrolyte contained in the measurement cell. At this moment start the stopclock and/or the recorder and continue the test at least until the potential generated corresponds to a pCl value of 3,8.

NOTE 8 It is very important to follow exactly the directions for the use of the specific electrodes and of the auxiliary equipment.

11 Expression of results

Record the time, in minutes, taken to attain a pCl value of 3,8 in the measurement cell solution. Record the average of the values obtained from the two tests. Report the result as the stability time t_s at the decomposition temperature.

12 Precision

In the year 1990, international round-robin tests were carried out to evaluate the precision of the method described in this part of ISO 182 in comparison with the pH-meter method (ISO 182-2). Three different PVC compounds were tested:

1	PVC-U	(unplasticized PVC) compound for pipes No. 1;
2	PVC-U	compound for pipes No. 2;
3	VC/VAC	(vinyl chloride/vinyl acetate copolymer) compound for phonograph records.

the following values for the reproducibility and the general mean stability time m were obtained:

$$R = r = 2,4$$

$$m = 77,87 \text{ min}$$

The tests were conducted by three laboratories:

A	Italy;
B	France;
C	Belgium.

All tests were conducted with dehydrochlorination cell A.

The measurements were made using two different specific electrodes for the Cl^- ions, and compared with those obtained using a pH-meter. The results obtained are shown in table 1.

12.1 Repeatability, r

By application of the statistical method of ISO 5725 to the results obtained for samples 1 and 2 (PVC-U), a value of $r = 2,4$ for the repeatability was obtained.

The calculation was not made for sample 3, because insufficient data were available due to problems caused by melting of the compound; however, at 200 °C the standard deviations appeared to be very low.

12.2 Reproducibility, R

From the same table of results, by the treatment of the results obtained by two laboratories on sample 1,

12.3 Comparison with the pH-meter method (ISO 182-2)

From the data shown in the right-hand columns of table 1, the results of the statistical calculation are:

$$m = 78,51 \text{ min}$$

$$r = 4,2$$

$$R = r = 4,2$$

These results are in the same range as those obtained by the pCl method.

12.4 Conclusions

The results obtained in the round-robin confirm that

- the repeatability of the potentiometric measurements is of the same order of magnitude as that of the pH and conductometric methods;
- the reproducibility is also comparable with that of the pH method, if the calibration of the potentiometric cell has been properly conducted.

The precision may be affected by:

- the decomposition temperature (oil bath temperature) and the granular size of the sample, analogous to the pH and conductometric methods (see ISO 182-3:1993, 12.4);

Table 1 — Stability times obtained by three laboratories on three PVC samples by the pCl and the pH methods

Sample	Laboratory	pCl method (ISO 182-4)					pH method (ISO 182-2)		
		No. of tests	Temperature °C	Mean stability time min	Standard deviation min	Electrode	No. of tests	Mean stability time min	Standard deviation min
1-PVC-U	A	2	200	75,60	1,5	Orion	2	79,5	1,5
1-PVC-U	B	5	200	78,72	0,6	Tacussel	5	78,18	1,5
2-PVC-U	C	5	200	87,00	1,55	Orion	5	88,0	1,5
3-VC/VAC	A	2	200	18,5	0,1	Orion	—	—	—
3-VC/VAC	B	5	200	21,3	1,2	Tacussel	5	18,44	
3-VC/VAC	C	5	180	60,0	3,0	Orion	5	57	2,73