

---

---

**Hydraulic fluid power — Single rod  
cylinders, 16 MPa (160 bar) compact  
series with bores from 250 mm to  
500 mm — Accessory mounting  
dimensions**

*Transmissions hydrauliques — Vérins à simple tige, série compacte  
16 MPa (160 bar) d'alésages 250 mm à 500 mm — Dimensions  
d'interchangeabilité des accessoires*

iTeh STANDARD REVIEW  
(standards.iteh.ai)

ISO 13726:2008

<https://standards.iteh.ai/catalog/standards/sist/36a81ba2-7d27-4822-8230-a7c0aa9ac1bc/iso-13726-2008>



**PDF disclaimer**

This PDF file may contain embedded typefaces. In accordance with Adobe's licensing policy, this file may be printed or viewed but shall not be edited unless the typefaces which are embedded are licensed to and installed on the computer performing the editing. In downloading this file, parties accept therein the responsibility of not infringing Adobe's licensing policy. The ISO Central Secretariat accepts no liability in this area.

Adobe is a trademark of Adobe Systems Incorporated.

Details of the software products used to create this PDF file can be found in the General Info relative to the file; the PDF-creation parameters were optimized for printing. Every care has been taken to ensure that the file is suitable for use by ISO member bodies. In the unlikely event that a problem relating to it is found, please inform the Central Secretariat at the address given below.

**iTeh STANDARD PREVIEW**  
**(standards.iteh.ai)**

ISO 13726:2008

<https://standards.iteh.ai/catalog/standards/sist/36a81ba2-7d27-4822-8230-a7c0aa9ac1bc/iso-13726-2008>



**COPYRIGHT PROTECTED DOCUMENT**

© ISO 2008

All rights reserved. Unless otherwise specified, no part of this publication may be reproduced or utilized in any form or by any means, electronic or mechanical, including photocopying and microfilm, without permission in writing from either ISO at the address below or ISO's member body in the country of the requester.

ISO copyright office  
Case postale 56 • CH-1211 Geneva 20  
Tel. + 41 22 749 01 11  
Fax + 41 22 749 09 47  
E-mail [copyright@iso.org](mailto:copyright@iso.org)  
Web [www.iso.org](http://www.iso.org)

Published in Switzerland

## Foreword

ISO (the International Organization for Standardization) is a worldwide federation of national standards bodies (ISO member bodies). The work of preparing International Standards is normally carried out through ISO technical committees. Each member body interested in a subject for which a technical committee has been established has the right to be represented on that committee. International organizations, governmental and non-governmental, in liaison with ISO, also take part in the work. ISO collaborates closely with the International Electrotechnical Commission (IEC) on all matters of electrotechnical standardization.

International Standards are drafted in accordance with the rules given in the ISO/IEC Directives, Part 2.

The main task of technical committees is to prepare International Standards. Draft International Standards adopted by the technical committees are circulated to the member bodies for voting. Publication as an International Standard requires approval by at least 75 % of the member bodies casting a vote.

Attention is drawn to the possibility that some of the elements of this document may be the subject of patent rights. ISO shall not be held responsible for identifying any or all such patent rights.

ISO 13726 was prepared by Technical Committee ISO/TC 131, *Fluid power systems*, Subcommittee SC 3, *Cylinders*.

This second edition cancels and replaces the first edition (ISO 13726:1998), which has been technically revised.

**iTeh STANDARD PREVIEW**  
**(standards.iteh.ai)**  
  
ISO 13726:2008  
<https://standards.iteh.ai/catalog/standards/sist/36a81ba2-7d27-4822-8230-a7c0aa9ac1bc/iso-13726-2008>

## Introduction

In hydraulic fluid power systems, power is transmitted and controlled through a liquid under pressure within an enclosed circuit.

One component of such systems is the fluid power cylinder. This is a device that converts power into linear mechanical force and motion. It consists of a movable element, i.e. a piston and piston rod, operating within a cylindrical bore.

## iTeh STANDARD PREVIEW (standards.iteh.ai)

[ISO 13726:2008](https://standards.iteh.ai/catalog/standards/sist/36a81ba2-7d27-4822-8230-a7c0aa9ac1bc/iso-13726-2008)

<https://standards.iteh.ai/catalog/standards/sist/36a81ba2-7d27-4822-8230-a7c0aa9ac1bc/iso-13726-2008>

# Hydraulic fluid power — Single rod cylinders, 16 MPa (160 bar) compact series with bores from 250 mm to 500 mm — Accessory mounting dimensions

## 1 Scope

This International Standard specifies the mounting dimensions required for interchangeability of accessories for 16 MPa (160 bar) compact cylinders conforming to ISO 6020-3. The accessories have been designed specifically for use with cylinders manufactured in accordance with ISO 6020-3, but this does not limit their application.

This International Standard covers the following accessories:

- AP2 — rod clevis, female thread (see Figure 1 and Table 1);
- AP4 — rod eye, plain, female thread (see Figure 2 and Table 2);
- AA4 - L — pivot pin (locking plate) (see Figure 3 and Table 3);
- AL6 — locking plate for pivot pin (see Figure 4 and Table 4);
- AA4 - S — pivot pin plain (see Figure 5 and Table 5).

These accessories are used on hydraulic cylinders for mechanically transmitting the cylinder force. The design of these accessories is based on the maximum forces resulting from the specified internal diameters of the cylinders and pressures according to ISO 2944 and ISO 3320.

## 2 Normative references

The following referenced documents are indispensable for the application of this document. For dated references, only the edition cited applies. For undated references, the latest edition of the referenced document (including any amendments) applies.

ISO 286-2, *ISO system of limits and fits — Part 2: Tables of standard tolerance grades and limit deviations for holes and shafts*

ISO 2944, *Fluid power systems and components — Nominal pressures*

ISO 3320, *Fluid power systems and components — Cylinder bores and piston rod diameters — Metric series*

ISO 5598, *Fluid power systems and components — Vocabulary*

ISO 6020-3, *Hydraulic fluid power — Mounting dimensions for single rod cylinders, 16 MPa (160 bar) series — Part 3: Compact series with bores from 250 mm to 500 mm*

ISO 8132, *Hydraulic fluid power — Single rod cylinders, 16 MPa (160 bar) medium and 25 MPa (250 bar) series — Mounting dimensions for accessories*

### 3 Terms and definitions

For the purposes of this document, the terms and definitions given in ISO 5598 apply.

### 4 Accessory mounting dimensions

- 4.1 The mounting dimensions for accessories are shown in Figures 1 to 5 and given in Tables 1 to 5.
- 4.2 For rod eyes with spherical bearing, use those specified in ISO 8132.

### 5 Material load capacity

All cross-sections shall be selected so that, under the maximum tensile load produced by the cylinder, the yield strength of the material used for the accessories is at least 2,5 times the maximum tensile load.

### 6 Application instructions

#### 6.1 Installation

- 6.1.1 A tolerance of f8 is recommended for plain bearing pins (see ISO 286-2).
- 6.1.2 The rod clevis and the rod eye shall be screwed firmly against the piston rod shoulder before locking.

#### 6.2 Lubrication

- 6.2.1 Sufficient lubrication for the satisfactory performance of these accessories shall be provided.
- 6.2.2 The method and frequency of such lubrication depends on the particular operating conditions.

### 7 Example of ordering designation

A plain rod eye with a bore of  $CK = 90$  mm (that is, type 90) shall be designated as follows:

**Rod eye ISO 13726 - 90**

### 8 Identification statement (reference to this International Standard)

It is strongly recommended to manufacturers who have chosen to conform to this International Standard that the following statement be used in test reports, catalogues and sales literature:

*“Interchangeable cylinder accessory mounting dimensions selected in accordance with ISO 13726, Hydraulic fluid power — Single rod cylinders, 16 MPa (160 bar) compact series with bores from 250 mm to 500 mm — Accessory mounting dimensions.”*

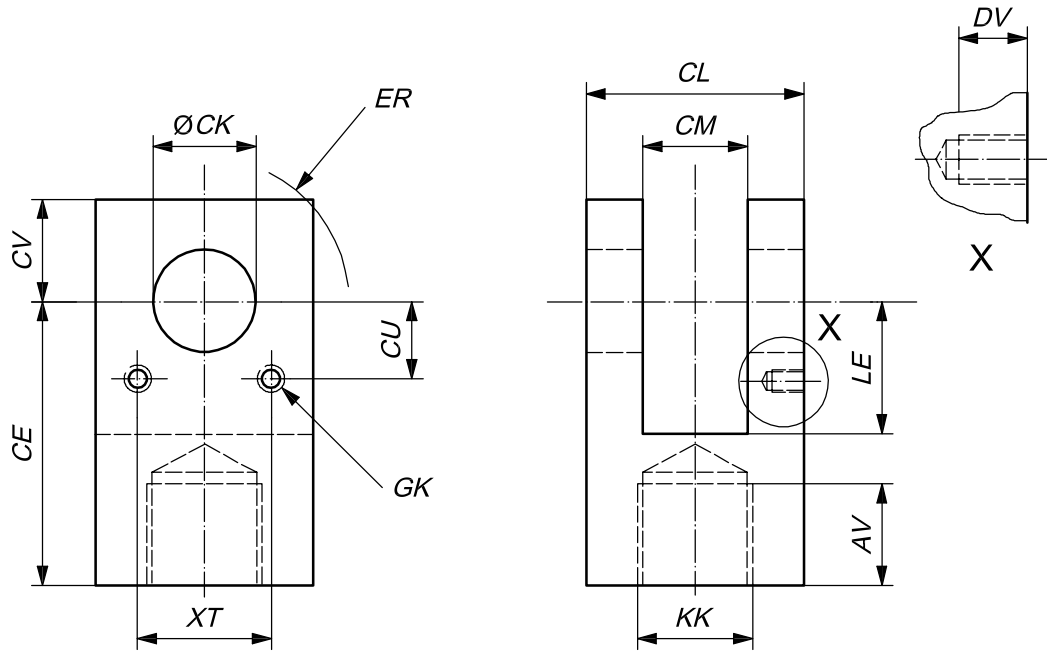

NOTE A suitable locking device is used.

Figure 1 — AP2 — Rod clevis, female thread

iTeh STANDARD PREVIEW

Table 1 — Dimensions of AP2 — Rod clevis, female thread

Dimensions in millimetres

Type	Typical bore	Nominal force N	KK	CK	CM	ER	CE	AV	LE	CL	XT	CU	GK <sup>a</sup>	DV <sup>b</sup> min.	CV min.
90	250	800 000	M100 × 3	90	90	100	245	113	115	180	100	56	M12	20	90
110	320	1 250 000	M125 × 4	110	110	120	290	126	130	220	120	66	M12	20	110
125	360	1 600 000	M125 × 4	125	125	140	310	126	150	250	120	72	M14	25	125
140	400	2 000 000	M160 × 4	140	140	160	365	161	170	280	140	77	M14	25	140
180	500	3 200 000	M200 × 4	180	180	200	470	205	210	360	180	92	M16	25	180

<sup>a</sup> Optional – used with AA 4-L.

<sup>b</sup> Optional.

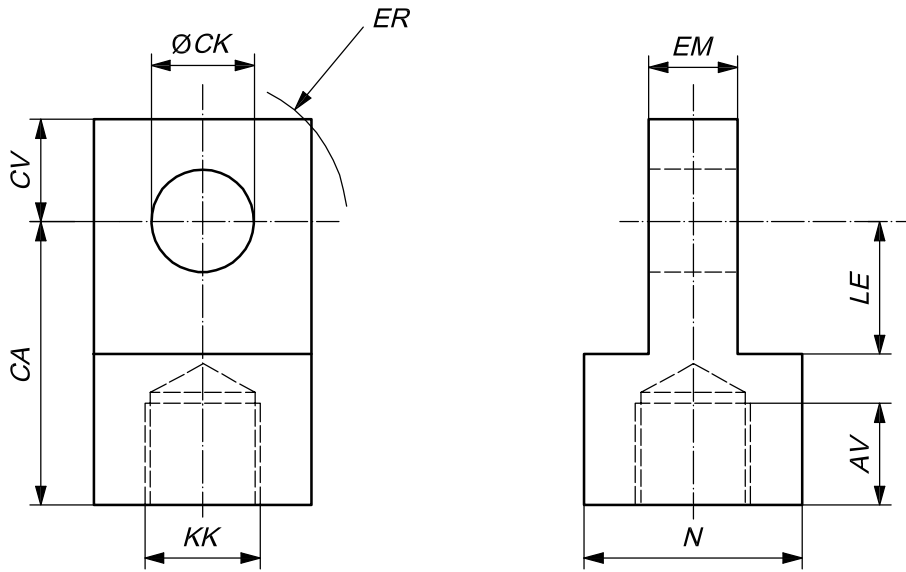

NOTE A suitable locking device is used.

Figure 2 — AP4 — Rod eye, plain, female thread

Table 2 — Dimensions of AP4 — Rod eye, plain, female thread

Dimensions in millimetres

Type	Typical bore	Typical rod	Nominal force N	KK 6H	CK H9	EM h13	ER max.	CA JS14	AV min.	LE min.	N max.	CV min.
90	250	140	800 000	M100 × 3	90	90	100	245	113	110	180	90
110	320	180	1 250 000	M125 × 4	110	110	120	290	126	130	220	110
125	360	180	1 600 000	M125 × 4	125	125	140	310	126	150	250	125
140	400	220	2 000 000	M160 × 4	140	140	160	365	161	170	280	140
180	500	280	3 200 000	M200 × 4	180	180	200	470	205	210	360	180



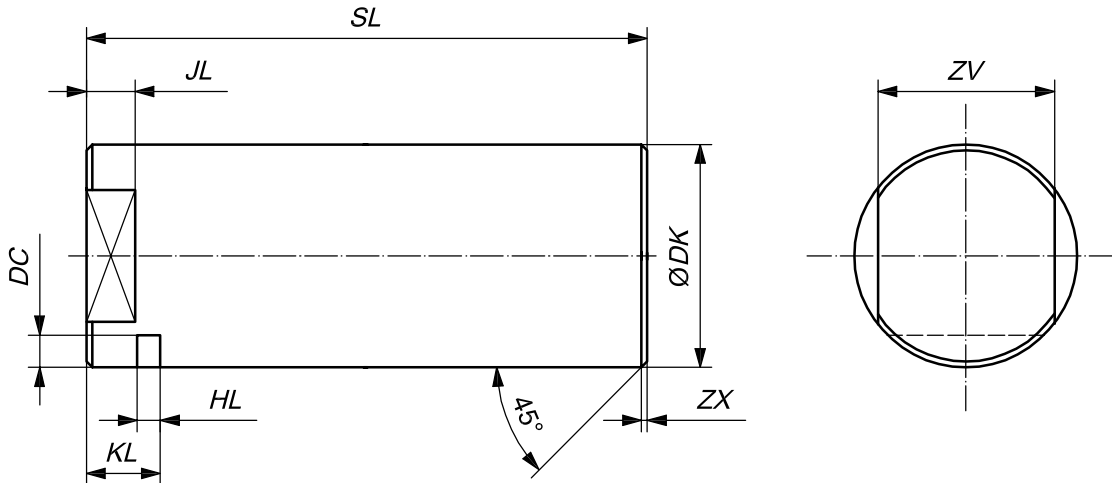

Figure 3 — AA4 - L — Pivot pin (locking plate)

Table 3 — Dimensions of AA4 - L — Pivot pin (locking plate)

Dimensions in millimetres

Type	Nominal force N	DK f8	SL $\pm 1$	KL 0 - 1	HL + 0,3 + 0,1	DC min.	JL max.	ZV h13	ZX
90	800 000	90	230	35	15	15	15	80	3
110	1 250 000	110	270	35	15	15	15	100	3
125	1 600 000	125	310	40	18	22,5	15	115	3
140	2 000 000	140	340	40	18	25	15	130	3
180	3 200 000	180	425	45	20	30	15	170	3