**Rubber, vulcanized or thermoplastic —
Hardness testing — Introduction and
guide**

*Caoutchouc vulcanisé ou thermoplastique — Essai de dureté —
Introduction et guide*

iTeh STANDARD PREVIEW
(standards.iteh.ai)

[ISO 18517:2005](https://standards.iteh.ai/catalog/standards/sist/7117bf28-a648-47a6-905f-0ddb1ec9cfdc/iso-18517-2005)

<https://standards.iteh.ai/catalog/standards/sist/7117bf28-a648-47a6-905f-0ddb1ec9cfdc/iso-18517-2005>



PDF disclaimer

This PDF file may contain embedded typefaces. In accordance with Adobe's licensing policy, this file may be printed or viewed but shall not be edited unless the typefaces which are embedded are licensed to and installed on the computer performing the editing. In downloading this file, parties accept therein the responsibility of not infringing Adobe's licensing policy. The ISO Central Secretariat accepts no liability in this area.

Adobe is a trademark of Adobe Systems Incorporated.

Details of the software products used to create this PDF file can be found in the General Info relative to the file; the PDF-creation parameters were optimized for printing. Every care has been taken to ensure that the file is suitable for use by ISO member bodies. In the unlikely event that a problem relating to it is found, please inform the Central Secretariat at the address given below.

iTeh STANDARD PREVIEW
(standards.iteh.ai)

[ISO 18517:2005](https://standards.iteh.ai/catalog/standards/sist/7117bf28-a648-47a6-905f-0ddb1ec9cfdc/iso-18517-2005)

<https://standards.iteh.ai/catalog/standards/sist/7117bf28-a648-47a6-905f-0ddb1ec9cfdc/iso-18517-2005>

© ISO 2005

All rights reserved. Unless otherwise specified, no part of this publication may be reproduced or utilized in any form or by any means, electronic or mechanical, including photocopying and microfilm, without permission in writing from either ISO at the address below or ISO's member body in the country of the requester.

ISO copyright office
Case postale 56 • CH-1211 Geneva 20
Tel. + 41 22 749 01 11
Fax + 41 22 749 09 47
E-mail copyright@iso.org
Web www.iso.org

Published in Switzerland

Contents

Page

Foreword.....	iv
1 Scope	1
2 Normative references	1
3 Terms and definitions.....	1
4 Indentation hardness.....	2
5 Types of hardness test.....	3
6 Significance.....	3
7 Uses of hardness tests.....	3
8 Choice of methods.....	4
9 Test piece	4
10 Standard hardness blocks.....	4
11 Comparison of hardness scales	4
Bibliography	5

iTeh STANDARD PREVIEW
(standards.iteh.ai)

[ISO 18517:2005](https://standards.iteh.ai/catalog/standards/sist/7117bf28-a648-47a6-905f-0ddb1ec9cfdc/iso-18517-2005)

<https://standards.iteh.ai/catalog/standards/sist/7117bf28-a648-47a6-905f-0ddb1ec9cfdc/iso-18517-2005>

Foreword

ISO (the International Organization for Standardization) is a worldwide federation of national standards bodies (ISO member bodies). The work of preparing International Standards is normally carried out through ISO technical committees. Each member body interested in a subject for which a technical committee has been established has the right to be represented on that committee. International organizations, governmental and non-governmental, in liaison with ISO, also take part in the work. ISO collaborates closely with the International Electrotechnical Commission (IEC) on all matters of electrotechnical standardization.

International Standards are drafted in accordance with the rules given in the ISO/IEC Directives, Part 2.

The main task of technical committees is to prepare International Standards. Draft International Standards adopted by the technical committees are circulated to the member bodies for voting. Publication as an International Standard requires approval by at least 75 % of the member bodies casting a vote.

Attention is drawn to the possibility that some of the elements of this document may be the subject of patent rights. ISO shall not be held responsible for identifying any or all such patent rights.

ISO 18517 was prepared by Technical Committee ISO/TC 45, *Rubber and rubber products*, Subcommittee SC 2, *Testing and analysis*.

iTeh STANDARD PREVIEW (standards.iteh.ai)

[ISO 18517:2005](https://standards.iteh.ai/catalog/standards/sist/7117bf28-a648-47a6-905f-0ddb1ec9cfdc/iso-18517-2005)

<https://standards.iteh.ai/catalog/standards/sist/7117bf28-a648-47a6-905f-0ddb1ec9cfdc/iso-18517-2005>

Rubber, vulcanized or thermoplastic — Hardness testing — Introduction and guide

1 Scope

This International Standard provides guidance on the determination of the hardness of vulcanized and thermoplastic rubbers.

It is intended to provide an understanding of the significance of hardness as a material property and to assist in the selection of an appropriate test method.

2 Normative references

The following referenced documents are indispensable for the application of this document. For dated references, only the edition cited applies. For undated references, the latest edition of the referenced document (including any amendments) applies.

ISO 48, *Rubber, vulcanized or thermoplastic — Determination of hardness (hardness between 10 IRHD and 100 IRHD)*

ISO 7267-1, *Rubber-covered rollers — Determination of apparent hardness — Part 1: IRHD method*

ISO 7267-2, *Rubber-covered rollers — Determination of apparent hardness — Part 2: Shore-type durometer method*

ISO 7267-3, *Rubber-covered rollers — Determination of apparent hardness — Part 3: Pusey and Jones method*

ISO 7619-1, *Rubber, vulcanized or thermoplastic — Determination of indentation hardness — Part 1: Durometer method (Shore hardness)*

ISO 7619-2, *Rubber, vulcanized or thermoplastic — Determination of indentation hardness — Part 2: IRHD pocket meter method*

ISO 18898, *Rubber — Calibration and verification of hardness testers*

3 Terms and definitions

For the purposes of this document, the following terms and definitions apply.

3.1

international rubber hardness degrees

IRHD

hardness scale chosen so that “0” represents the hardness of material having a Young’s modulus of zero and “100” represents the hardness of a material of infinite Young’s modulus

NOTE The following conditions are fulfilled over most of the normal range of hardness:

- a) one international rubber hardness degree always represents approximately the same proportionate difference in the Young's modulus;
- b) for highly elastic rubbers, the IRHD and Shore A durometer scales are comparable.

3.2 standard hardness

S
hardness, in international rubber hardness degrees, obtained using the procedures described in ISO 48 on test pieces of the standard thickness and not less than the minimum lateral dimensions specified

3.3 apparent hardness

hardness, in international rubber hardness degrees, obtained using the procedures described in ISO 48 on test pieces of non-standard dimensions

4 Indentation hardness

The term hardness when applied to rubbers refers to a measure of stiffness obtained from an indentation test. An indenter is pressed into the rubber under a given force and the resulting indentation measured as illustrated in Figure 1. In contrast to some methods for other materials, the indentation is measured with the load applied.

iTeh STANDARD PREVIEW

In most tests the indenter is surrounded by a foot which rests on the test piece under a given force. In dead-load tests (see Clause 5), the measured indentation is the difference between the indentation caused by a small initial force and that caused by a larger final force.

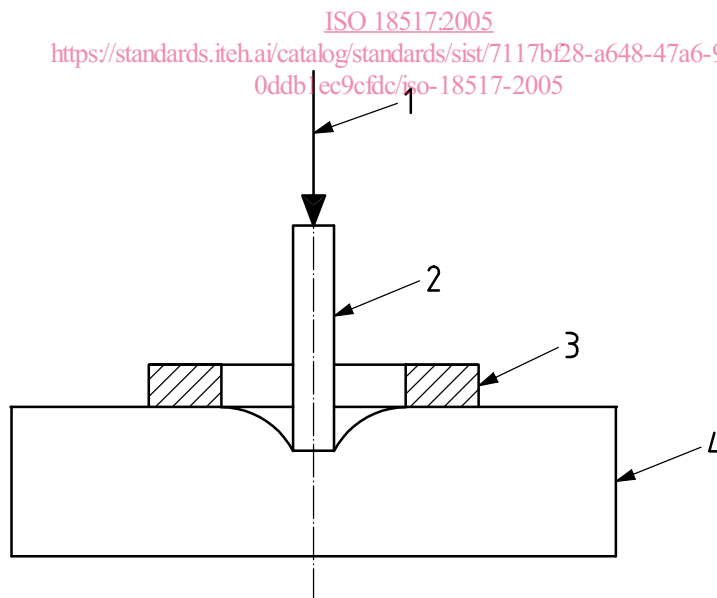

- Key**
- 1 weight or spring to apply force
 - 2 indenter
 - 3 pressure foot
 - 4 test piece

Figure 1 — Principle of hardness test

5 Types of hardness test

Distinction is made between dead-load tests, where the indenting force is produced by a weight, and so-called durometers or pocket hardness meters, where the indenting force is applied by a spring.

Dead-load methods using a ball indenter with hardness expressed in international rubber hardness degrees (IRHD) are specified in ISO 48. This hardness scale is based on the relationship defined in 3.1 and a probit curve relating $\log_{10}(\text{modulus})$ to the hardness in IRHD. This results in a scale from 0 to 100 for infinitely soft to infinitely rigid materials. The definition of IRHD was chosen to give reasonable agreement with the Shore A scale described below.

The “normal” dead-load method is intended for use with rubbers in the range 35 IRHD to 85 IRHD and there are modifications for low- and high-hardness rubbers. Method L covers the hardness range from 10 IRHD to 35 IRHD and method H covers the range from 85 IRHD to 100 IRHD. The micro dead-load method is for use on thin test pieces and uses an indenter with diameter one-sixth of that for the “normal” method.

ISO 48 also specifies modified procedures for use on curved test pieces, with the result being expressed as apparent hardness.

For rubber rollers, the Pusey and Jones dead-load instrument is specified in ISO 7267-3 in addition to the ISO 48 and durometer methods in ISO 7267-1 and ISO 7267-2, respectively.

Durometers were originally intended to be hand-held but are now often mounted on a stand with a weight to apply the correct foot pressure. The best known are the Shore gauges, of which there are several different types to cover a range of materials, and which have been produced by a number of manufacturers. Shore A scale durometers for rubbers in the normal hardness range and D scale durometers for hard materials are standardized in ISO 7619-1 together with a micro instrument designated AM and an instrument for soft materials designated AO. The type A uses a truncated cone indenter, types D and AM use a radiused cone, whilst type AO uses a ball indenter. ISO 7619-2 specifies a pocket meter with a ball indenter designed to read in the IRHD scale.

ISO 18517:2005

<https://standards.iteh.ai/catalog/standards/sist/7117bf28-a648-47a6-905f-0ddb1ec9cfdc/iso-18517-2005>

6 Significance

In principle, hardness can be related to the modulus of the rubber and empirical formulae can be found in textbooks. A relationship for ball indentation is given in ISO 48 together with graphs of hardness against $\log(\text{modulus})$. The relationship is only valid for a perfectly elastic rubber and in practice can only be considered as approximate.

Because of the tenuous relation with Young's or shear modulus, hardness cannot be considered as a fundamental material property. However, because of the simplicity and cheapness of hardness testing together with its essentially non-destructive nature, hardness is universally used as a convenient measure of stiffness.

A limitation which is not always appreciated is the discrimination and precision obtainable. Generally, the best that can be achieved is ± 1 IRHD which translates to of the order of ± 4 % modulus in the middle of the scale and ± 16 % at very low and high hardnesses.

7 Uses of hardness tests

Hardness is a measure of stiffness or modulus which is an important property of rubbers in almost all applications. Its enormous popularity is due to its practical simplicity, versatility in terms of the test piece required, cheapness and non-destructive nature. Because of this, it is universally used as a quality control test, for trouble shooting, as a classification parameter for both compounds and products and as a requirement in material and product specifications. Hardness is widely used as a convenient, non-destructive measure of the state and uniformity of cure of a range of vulcanized products. It can also be used to track ageing, contamination and porosity and so is suitable for diagnostic purposes.

8 Choice of methods

When a portable, hand-held instrument is needed, for example for testing products, then a spring-loaded durometer or pocket hardness meter is used. The type A durometer is by far the most popular but the type AO and the IRHD pocket meter have the advantage of a ball indenter which is less prone to damage than a truncated cone. The IRHD pocket hardness meter also has a very low variation in spring force over the hardness range and the results correspond directly to those obtained with dead-load instruments. For very hard rubbers and thin test pieces, types D and AM, respectively, are appropriate. The Shore D scale is usually associated with plastics materials but is in common use for harder thermoplastic elastomers and ebonite and is sometimes preferred over Shore A and IRHD scales for rubbers over 90 IRHD.

NOTE Durometers have been produced with a built-in device that guarantees the application of the correct foot pressure regardless of the force applied by the operator.

The dead-load methods are intended to be the preferred approach for standard test pieces in the laboratory, the micro dead-load method being used where only thin pieces of material are available. The high and low hardness scales are intended to improve the discrimination at the extremes of the scale but it has been shown that, for the high scale at least, there is no advantage (for further details, see Reference [1]). However, many workers prefer to use the Shore-type durometers on a stand (so they are no longer portable).

The rationale for using the dead-load instruments is that a weight gives a constant force and is more stable than a spring. A systematic evaluation of the parameters affecting precision has shown that the dead-load methods are superior in this respect (for further details, see Reference [2]).

9 Test piece

iTeh STANDARD PREVIEW

(standards.iteh.ai)

In practice, hardness measurements are made on test pieces and products of various shapes and sizes, particularly when using hand-held durometers. The results obtained are very dependent on test piece dimensions, particularly thickness, and hence it is essential that only the standard test pieces are used to obtain comparative results. Results on non-standard test pieces are termed apparent hardness in ISO 48.

The main limitation of apparent hardness measurements is that the results are likely to differ from those made on standard test pieces and are only comparable with tests made in the same way using the same geometry. When no micro instrument is available for testing thin material, several plies can be used to obtain a satisfactory test piece thickness, but again results may vary from those obtained with standard test pieces.

10 Standard hardness blocks

Hardness testers should be calibrated in accordance with ISO 18898, but sets of standard reference blocks are available which are very useful for checking between calibrations, particularly for hand-held durometers and pocket hardness meters.

11 Comparison of hardness scales

For perfectly elastic rubbers, the IRHD and Shore A scales are virtually identical except at the low and high ends of the scale. For practical materials, the correlation will be less good and material-dependent. Empirical relations between the A and D scales have been published (for further details, see Reference [3]) but they must be considered as a first approximation. One factor which may be significant is the effect of differences in the time of application of the load, particularly with thermoplastic elastomers and vulcanized rubbers exhibiting high hysteresis.

In theory, the normal and micro dead-load instruments should give equivalent results but, because of thickness and surface layer effects (the surface can be harder than the interior), this is not always the case and significant differences are possible.

Bibliography

- [1] KUCHERSKII, A.M., and KAPOROVSKII, B.M.: *Polym. Test.*, 14, 1995, 3
- [2] BROWN, R.P., and SOEKARNEIN, A.: *Polym. Test.*, 10, 1991, 2
- [3] BROWN, R.P.: *Physical Testing of Rubber*, Chapman and Hall, London, 1996

iTeh STANDARD PREVIEW
(standards.iteh.ai)

[ISO 18517:2005](https://standards.iteh.ai/catalog/standards/sist/7117bf28-a648-47a6-905f-0ddb1ec9cfdc/iso-18517-2005)

<https://standards.iteh.ai/catalog/standards/sist/7117bf28-a648-47a6-905f-0ddb1ec9cfdc/iso-18517-2005>