**Gardening machinery — Powered
material-collecting systems — Safety**

*Matériel de jardinage — Systèmes motorisés de collecte
des matériaux — Sécurité*

iTeh STANDARD PREVIEW
(standards.iteh.ai)

[ISO 21628:2008](https://standards.iteh.ai/catalog/standards/sist/53293ff50c7-4494-9302-25233dfb6765/iso-21628-2008)

<https://standards.iteh.ai/catalog/standards/sist/53293ff50c7-4494-9302-25233dfb6765/iso-21628-2008>



PDF disclaimer

This PDF file may contain embedded typefaces. In accordance with Adobe's licensing policy, this file may be printed or viewed but shall not be edited unless the typefaces which are embedded are licensed to and installed on the computer performing the editing. In downloading this file, parties accept therein the responsibility of not infringing Adobe's licensing policy. The ISO Central Secretariat accepts no liability in this area.

Adobe is a trademark of Adobe Systems Incorporated.

Details of the software products used to create this PDF file can be found in the General Info relative to the file; the PDF-creation parameters were optimized for printing. Every care has been taken to ensure that the file is suitable for use by ISO member bodies. In the unlikely event that a problem relating to it is found, please inform the Central Secretariat at the address given below.

iTeh STANDARD PREVIEW
(standards.iteh.ai)

ISO 21628:2008

<https://standards.iteh.ai/catalog/standards/sist/53293ff5-50c7-4494-9302-25233dfb6765/iso-21628-2008>



COPYRIGHT PROTECTED DOCUMENT

© ISO 2008

All rights reserved. Unless otherwise specified, no part of this publication may be reproduced or utilized in any form or by any means, electronic or mechanical, including photocopying and microfilm, without permission in writing from either ISO at the address below or ISO's member body in the country of the requester.

ISO copyright office
Case postale 56 • CH-1211 Geneva 20
Tel. + 41 22 749 01 11
Fax + 41 22 749 09 47
E-mail copyright@iso.org
Web www.iso.org

Published in Switzerland

Foreword

ISO (the International Organization for Standardization) is a worldwide federation of national standards bodies (ISO member bodies). The work of preparing International Standards is normally carried out through ISO technical committees. Each member body interested in a subject for which a technical committee has been established has the right to be represented on that committee. International organizations, governmental and non-governmental, in liaison with ISO, also take part in the work. ISO collaborates closely with the International Electrotechnical Commission (IEC) on all matters of electrotechnical standardization.

International Standards are drafted in accordance with the rules given in the ISO/IEC Directives, Part 2.

The main task of technical committees is to prepare International Standards. Draft International Standards adopted by the technical committees are circulated to the member bodies for voting. Publication as an International Standard requires approval by at least 75 % of the member bodies casting a vote.

Attention is drawn to the possibility that some of the elements of this document may be the subject of patent rights. ISO shall not be held responsible for identifying any or all such patent rights.

ISO 21628 was prepared by Technical Committee ISO/TC 23, *Tractors and machinery for agriculture and forestry*, Subcommittee SC 13, *Powered lawn and garden equipment*.

iTeh STANDARD PREVIEW
(standards.iteh.ai)

ISO 21628:2008

<https://standards.iteh.ai/catalog/standards/sist/53293ff5-50c7-4494-9302-25233dfb6765/iso-21628-2008>

Introduction

The structure of safety standards in the field of machinery is as follows:

- a) type-A standards (basic safety standards) give basic concepts, principle for design, and general aspects that can be applied to machinery;
- b) type-B standards (generic safety standards) dealing with one safety aspect(s) or one or more type(s) of safeguards that can be used across a wide range of machinery:
 - type-B1 standards on particular safety aspects (e.g. safety distances, surface temperature, noise);
 - type-B2 standards on safeguards (e.g. two-hand controls, interlocking devices, pressure sensitive devices, guards);
- c) type-C standards (machinery safety standards) dealing with detailed safety requirements for a particular machine or group of machines.

This document is a type C standard as stated in ISO 12100-1.

When provisions of this type C standard are different from those which are stated in type A or B standards, the provisions of this type C standard take precedence over the provisions of the other standards for machines that have been designed and built according to the provisions of this type C standard.

The machinery concerned and the extent to which hazards, hazardous situations and events are covered are indicated in the scope of this document. These hazards are specific to material collecting systems.

Gardening machinery — Powered material-collecting systems — Safety

1 Scope

This International Standard gives safety requirements and the means for their verification specific to the design and construction of powered material-collecting systems used in agriculture, gardening and area maintenance (e.g. landscaping). It is applicable to mounted, semi-mounted or trailed machines manufactured after the date of its publication.

It specifies means for eliminating or reducing mechanical hazards when the material-collecting system is used as intended.

It does not deal with environmental hazards, road safety, electromagnetic compatibility, power take-off (PTO), PTO drive shaft guarding or control requirements.

2 Normative references

iTeh STANDARD PREVIEW
(standards.iteh.ai)

The following referenced documents are indispensable for the application of this document. For dated references, only the edition cited applies. For undated references, the latest edition of the referenced document (including any amendments) applies.

ISO 730-1, *Agricultural wheeled tractors — Rear-mounted three-point linkage — Part 1: Categories 1, 2, 3 and 4*

ISO 2332, *Agricultural tractors and machinery — Connection of implements via three-point linkage — Clearance zone around implement*

ISO 3600, *Tractors, machinery for agriculture and forestry, powered lawn and garden equipment — Operator's manuals — Content and presentation*

ISO 4413, *Hydraulic fluid power — General rules relating to systems*

ISO 11684, *Tractors, machinery for agriculture and forestry, powered lawn and garden equipment — Safety signs and hazard pictorials — General principles*

ISO 12100-1:2003, *Safety of machinery — Basic concepts, general principles for design — Part 1: Basic terminology, methodology*

ISO 13849-1, *Safety of machinery — Safety-related parts of control systems — Part 1: General principles for design*

ISO 13852:1996, *Safety of machinery — Safety distances to prevent danger zones being reached by the upper limbs*

3 Terms and definitions

For the purposes of this document, the following terms and definitions apply.

3.1 material-collecting system
mounted, semi-mounted or trailed machine used to collect grass and leaves by means of a vacuum provided by a blower

NOTE The collected material can include other organic or non-organic material present as debris on the working area.

3.2 inlet device
opening of the blower casing at the suction side to which the suction hose or pipe is connected

3.3 discharge chute
opening of the blower casing allowing the transport of the material from the blower to the hopper

3.4 normal operation and service
intended use of the machine in compliance with the information for operation, service and safe practices

4 Safety requirements

4.1 Fundamental principles, design guidance

The machine shall be designed according to the principles of risk reduction specified in ISO 12100-1:2003, Clause 5, for hazards relevant but not significant.

Unless specified otherwise in this International Standard, openings and relative safety distances shall be in accordance with ISO 13852:1996, Tables 1, 3, 4 and 6.

4.2 Access to the blower

4.2.1 Suction (inlet) side

The suction hose or pipe shall be fixed to the inlet device. The removal of the suction hose or pipe shall not be possible except by using a tool. The operator's manual shall include information about the removal of blockages [see 5.1.2 e)].

4.2.2 Discharge chute

4.2.2.1 The maximum size of the discharge chute opening shall be 625 cm².

4.2.2.2 To prevent access to hazardous parts of the blower, the machine shall comply with one or the other of the following.

- a) The minimum distance between the discharge chute opening and the outer contour of the blower shall be 850 mm.
- b) Alternatively, the minimum distance between the contour or parts of the machine restricting access to the blower and the outer contour of the blower shall be 850 mm. This requirement shall be verified using the arm test probe shown in Figure 1. The probe shall be applied in all directions in which the operator's arm could be used and in the shaded area shown in Figure 2. The 850 mm safety distance shall apply beneath the height of this shaded area, i.e. beneath a height of 700 mm. See Figure 2.

The plate of the probe shall be kept parallel to the machine. The arm test probe shall be applied with a force not exceeding 20 N.

The safety distance is measured as chain measurement.

- c) Alternatively, the discharge chute opening shall be in accordance with ISO 13852:1996, Tables 1, 3, 4 and 6. If this is achieved by additional means, such means shall be in place whenever operator access to the discharge chute opening is possible. They shall not be removable except using a tool and shall correspond to ISO 13849-1, category 1.
- d) Alternatively, means shall be provided to stop the blower — for example, when raising or opening the hopper — before direct operator access such as that described in b), above, is possible.

Dimensions in millimetres

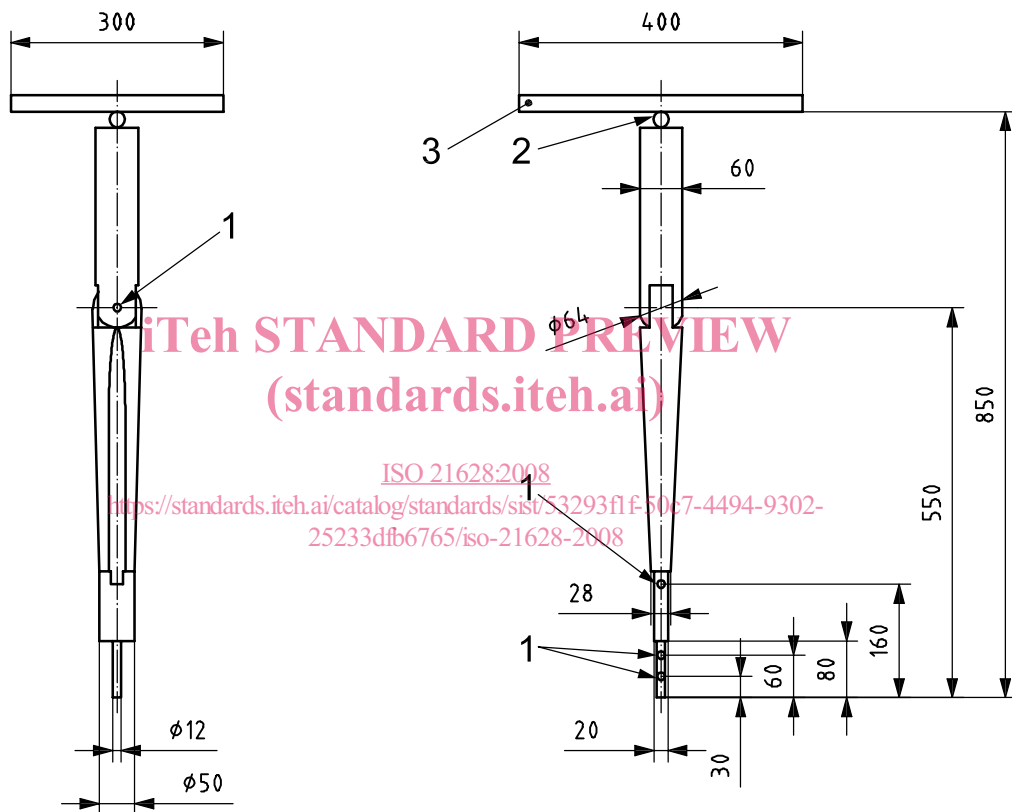

Key

- 1 articulation allowing rotation of $\pm 90^\circ$ about articulation axis
- 2 articulation allowing free rotation
- 3 plate representing the upper body

Figure 1 — Arm test probe

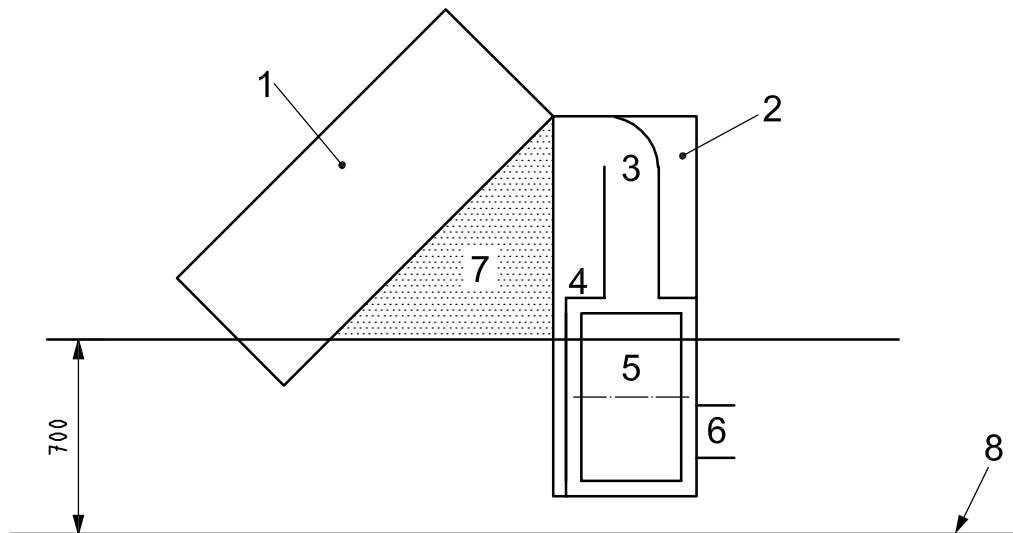

Key

- 1 hopper (opened position)
- 2 machine body
- 3 discharge chute opening
- 4 blower enclosure
- 5 blower (outer contour)
- 6 inlet device
- 7 access area to be tested
- 8 ground surface

iTeh STANDARD PREVIEW
(standards.iteh.ai)

ISO 21628:2008

<https://standards.iteh.ai/catalog/standards/sist/53293ff-f50c7-4494-9302-25233dfb6765/iso-21628-2008>

Figure 2 — Access area and machine

4.3 Direction of airflow

The airflow at the outlet at the rear side of the hopper shall be directed downwards to avoid contact with the collected material.

4.4 Hopper discharge

The linkage system for raising or lowering the hopper during its discharge shall be designed so that pinching and shearing points are avoided and a distance of 25 mm between moving linkage components is maintained.

Information on possible hazards that could occur when the door of the hopper is opened shall be provided on the machine and in the operator's manual [see 5.1.2 g)].

4.5 Stability

Empty material-collecting systems shall be designed to be stable when dismantled and parked according to the operator's manual on firm ground, with an inclination up to 8,5° in any direction. If needed, means to block the transport wheels shall be provided.

4.6 Clearance zone of mounted machines

Material-collecting systems to be attached to three-point linkage hitches according to ISO 730-1 shall provide a clearance zone as specified in ISO 2332.

4.7 Hydraulics

Hydraulic components shall be in accordance with ISO 4413.

5 Information for use

5.1 Operator's manual

5.1.1 Each machine shall be provided with an operator's manual, whose content and presentation shall be in accordance with ISO 3600.

5.1.2 Comprehensive instructions for, and information on, all aspects of the safe use of the machine, including personal protective equipment requirements and the need for training, if necessary, shall be provided. At least the following information shall be included, as appropriate:

- a) foreseen uses of the machine;
- b) initial set-up of the machinery (unless this will be carried out by the dealer);
- c) the correct methods of mounting and dismounting;
- d) compatibility with the tractors (e.g. hitching system, engine power, stability, braking, steering);
- e) removal of blockages (4.2.);
- f) pinching and shearing points (when raising and lowering the hopper (4.4));
- g) hazards related to door opening (4.5);
- h) a warning that the machine may be operated only when correctly attached to the vehicle or machine.

5.2 Safety and instructional signs

5.2.1 Safety signs shall be appropriately displayed when necessary to alert the operator and others of the risk of personal injury during normal operation and service (see also 4.4).

5.2.2 Safety signs shall be in accordance with ISO 11684.