



SLOVENSKI STANDARD

SIST EN 15382:2018

01-junij-2018

Nadomešča:
SIST EN 15382:2013

Geosintetične ovire - Zahtevane lastnosti za uporabo v infrastrukturi transporta

Geosynthetic barriers - Characteristics required for use in transportation infrastructure

Geosynthetische Dichtungsbahnen - Eigenschaften, die für die Anwendung in Verkehrsbauten erforderlich sind

Barrières géosynthétiques - Caractéristiques requises pour l'utilisation dans l'infrastructure des voies de transport

STANDARD PREVIEW
(standards.iteh.ai)
SIST EN 15382:2018
<https://standards.iteh.ai/catalog/standards/sist/19d2c2cd-2e1f-478b-bc07-70582/478b-bc07-70582-2018>

Ta slovenski standard je istoveten z: EN 15382:2018

ICS:

59.080.70	Geotekstilije	Geotextiles
93.080.20	Materiali za gradnjo cest	Road construction materials

SIST EN 15382:2018 en,fr,de

iTeh STANDARD PREVIEW
(standards.iteh.ai)

SIST EN 15382:2018

<https://standards.iteh.ai/catalog/standards/sist/f9d2c2cd-2e1f-478b-bc07-163cdde70582/sist-en-15382-2018>

EUROPEAN STANDARD

EN 15382

NORME EUROPÉENNE

EUROPÄISCHE NORM

March 2018

ICS 59.080.70; 93.080.20

Supersedes EN 15382:2013

English Version

Geosynthetic barriers - Characteristics required for use in transportation infrastructure

Géomembranes et géosynthétiques bentonitiques -
Caractéristiques requises pour l'utilisation dans les
infrastructures de transport

Geosynthetische Dichtungsbahnen - Eigenschaften, die
für die Anwendung in Verkehrsbauten erforderlich
sind

This European Standard was approved by CEN on 5 November 2017.

CEN members are bound to comply with the CEN/CENELEC Internal Regulations which stipulate the conditions for giving this European Standard the status of a national standard without any alteration. Up-to-date lists and bibliographical references concerning such national standards may be obtained on application to the CEN-CENELEC Management Centre or to any CEN member.

This European Standard exists in three official versions (English, French, German). A version in any other language made by translation under the responsibility of a CEN member into its own language and notified to the CEN-CENELEC Management Centre has the same status as the official versions.

CEN members are the national standards bodies of Austria, Belgium, Bulgaria, Croatia, Cyprus, Czech Republic, Denmark, Estonia, Finland, Former Yugoslav Republic of Macedonia, France, Germany, Greece, Hungary, Iceland, Ireland, Italy, Latvia, Lithuania, Luxembourg, Malta, Netherlands, Norway, Poland, Portugal, Romania, Serbia, Slovakia, Slovenia, Spain, Sweden, Switzerland, Turkey and United Kingdom.



EUROPEAN COMMITTEE FOR STANDARDIZATION
COMITÉ EUROPÉEN DE NORMALISATION
EUROPÄISCHES KOMITEE FÜR NORMUNG

CEN-CENELEC Management Centre: Rue de la Science 23, B-1040 Brussels

Contents

	Page
European foreword.....	4
Introduction	5
1 Scope	6
2 Normative references	6
3 Terms, definitions and abbreviations	9
3.1 Terms and definitions	9
3.2 Abbreviations	10
4 Characteristics and corresponding methods of test	11
4.1 General.....	11
4.2 Types of application.....	11
4.3 Relevant characteristics	13
4.4 Characteristics relevant to specific conditions of use	20
4.4.1 General.....	20
4.4.2 Burst strength and elongation.....	20
4.4.3 Tear strength	20
4.4.4 Friction characteristics (direct shear and inclined plane tests).....	20
4.4.5 Low temperature behaviour	20
4.4.6 Weathering.....	20
4.4.7 Resistance to wetting and drying	21
4.4.8 Freeze-thaw cycle resistance	21
4.4.9 Resistance to root penetration	21
4.4.10 Chemical resistance.....	21
4.5 Release of dangerous substances.....	21
5 Assessment and verification of constancy of performance (AVCP)	21
5.1 General.....	21
5.2 Type testing.....	22
5.2.1 General.....	22
5.2.2 Test samples, testing and compliance criteria	22
5.2.3 Test reports.....	23
5.2.4 Shared other party results.....	23
5.2.5 Cascading determination of the product type results	24
5.3 Factory production control (FPC)	25
5.3.1 General.....	25
5.3.2 Requirements	25
5.3.3 Product specific requirements.....	31
5.3.4 Initial inspection of factory and of FPC	32
5.3.5 Continuous surveillance of FPC.....	32
5.3.6 Procedure for modifications	32
5.3.7 One-off products, pre-production products (e.g. prototypes) and products produced in very low quantity	32
Annex A (normative) Durability of geosynthetic barriers	34
A.1 General.....	34
A.1.1 Service Life.....	34
A.1.2 Type testing of durability.....	34

A.1.3	Mechanisms of degradation.....	35
A.1.4	Use of rework material.....	35
A.1.5	Recycled materials.....	35
A.2	Weathering.....	35
A.2.1	General.....	35
A.2.2	Direct tests and accelerated tests.....	36
A.2.3	Period of exposure.....	36
A.3	Products used with a service life up to 5 years.....	37
A.4	Other applications and service life of 25 years and 50 years.....	37
A.4.1	General.....	37
A.4.2	Tests for PE type of GBR-P.....	38
A.4.3	Tests for FPO-type of GBR-P.....	39
A.4.4	Tests for EPDM type of GBR-P.....	40
A.4.5	Tests for GBR-P made of PVC-P.....	40
A.4.6	Tests for clay geosynthetic barriers (GBR-C).....	41
A.5	Durability tests on GBR-P.....	43
A.5.1	Introduction.....	43
A.5.2	Microbiological resistance.....	43
A.5.3	Resistance to environmental stress cracking.....	44
A.5.4	Resistance to leaching.....	45
A.5.5	Resistance to oxidation/thermal ageing.....	47
A.6	Evaluation tests on GBR-P and GBR-C.....	49
A.6.1	General.....	49
A.6.2	Evaluation by comparison of tensile properties.....	49
A.6.3	Evaluation by comparison of oxidative induction time (OIT) values.....	50
A.6.4	Evaluation by change in mass.....	50
A.6.5	Evaluation by change in water permeability.....	50
A.7	Durability tests on GBR-B.....	50
A.7.1	Introduction.....	50
A.7.2	Microbiological resistance.....	51
A.7.3	Resistance to environmental stress cracking.....	52
A.7.4	Resistance to leaching.....	52
A.7.5	Resistance to oxidation/thermal ageing.....	53
A.7.6	Weathering resistance.....	54
A.8	Evaluation tests on GBR-B.....	55
A.8.1	General.....	55
A.8.2	Evaluation by comparison of tensile properties.....	55
A.8.3	Evaluation by change in mass.....	55
A.8.4	Evaluation of water permeability.....	55
A.8.5	Evaluation of flow resistance at elevated temperature.....	56
A.8.6	Evaluation of flexibility at low temperature.....	56
A.8.7	Evaluation of ring and ball softening point temperature.....	56
Annex ZA	(informative) Clauses of this European Standard with Regulation (EU) No. 305/2011.....	57
Bibliography	61

EN 15382:2018 (E)**European foreword**

This document (EN 15382:2018) has been prepared by Technical Committee CEN/TC 189 “Geosynthetics”, the secretariat of which is held by NBN.

This European Standard shall be given the status of a national standard, either by publication of an identical text or by endorsement, at the latest by September 2018, and conflicting national standards shall be withdrawn at the latest by December 2019.

Attention is drawn to the possibility that some of the elements of this document may be the subject of patent rights. CEN shall not be held responsible for identifying any or all such patent rights.

This document supersedes EN 15382:2013.

This document has been prepared under a mandate given to CEN by the European Commission and the European Free Trade Association.

For relationship with Regulation (EU) No 305/2011, see informative Annex ZA, which is an integral part of this document.

The main changes with respect to the previous edition are listed below:

- STANDARD PREVIEW**
(standards.iteh.ai)
- the list of normative references has been updated;
 - in 3.1 three terms have been added;
 - in 3.2 list of abbreviations has been updated;
 - in 4.3, Table 1, has been modified to comply with the modified mandate M/386 (inclusion of elongation in separation and filtration functions) and has been technically revised, all H-coded characteristics have been replaced by “A”;
 - Clause 5 “Evaluation of conformity” has been superseded by new Clause 5 “Assessment and verification of constancy of performance (AVCP)”;
 - Annex A “Factory production control – Factory production control scheme” has been deleted;
 - former Annex B “Durability” becomes Annex A and has been totally revised;
 - Annex ZA has been updated according to new template to fulfil requirements of CPR, also examples for CE-marking have been deleted.

According to the CEN-CENELEC Internal Regulations, the national standards organizations of the following countries are bound to implement this European Standard: Austria, Belgium, Bulgaria, Croatia, Cyprus, Czech Republic, Denmark, Estonia, Finland, Former Yugoslav Republic of Macedonia, France, Germany, Greece, Hungary, Iceland, Ireland, Italy, Latvia, Lithuania, Luxembourg, Malta, Netherlands, Norway, Poland, Portugal, Romania, Serbia, Slovakia, Slovenia, Spain, Sweden, Switzerland, Turkey and the United Kingdom.

Introduction

This document allows manufacturers to describe geosynthetic barriers on the basis of declared values for characteristics relevant to the intended use and if tested to the specified method. It also includes procedures for assessment and verification of constancy of performance (AVCP) including the factory production control.

This document can also be used by designers, end-users and other interested parties as a tool to define relevant and appropriate characteristics for specifications.

Tests for several non-mandated characteristics are still under study and will be included when the standard is revised.

The term “product” used in this standard refers to a geosynthetic barrier, including polymeric geosynthetic barriers, clay geosynthetic barriers and bituminous geosynthetic barriers.

This document is part of a group of standards, addressing the requirements for geosynthetic barriers when used in a specific application.

Particular application cases can contain requirements about additional properties and – preferably standardized – test methods, if they are technically relevant and not conflicting with European Standards.

The design life of the product should be determined, since its function may be temporary, as construction expediency, or permanent, for the lifetime of the structure.

iTeh STANDARD PREVIEW
(standards.iteh.ai)

[SIST EN 15382:2018](https://standards.iteh.ai/catalog/standards/sist/f9d2c2cd-2e1f-478b-bc07-163cdde70582/sist-en-15382-2018)

<https://standards.iteh.ai/catalog/standards/sist/f9d2c2cd-2e1f-478b-bc07-163cdde70582/sist-en-15382-2018>

1 Scope

This European Standard specifies the characteristics of geosynthetic barriers including polymeric geosynthetic barriers, clay geosynthetic barriers and bituminous geosynthetic barriers, used as fluid barriers and separation layer in infrastructure works, e.g. roads, railroads, runways of airports, and the appropriate test methods to determine these characteristics.

Tunnels and associated underground structures are addressed in EN 13491.

The intended use of these products is to control the pathway of fluid through the construction and to limit any contamination, e.g. by de-icing products, of groundwater or water sources.

This European Standard is not applicable to geotextiles or geotextile-related products, as defined in EN ISO 10318-1.

This document provides for the assessment and verification of constancy of performance (AVCP) of the product to this European Standard including factory production control procedures.

This European Standard defines characteristics to be considered with regard to the presentation of performance.

This European Standard does not cover applications where the geosynthetic barrier will be in contact with water that has been treated for human consumption.

NOTE Where potable water is or can be in direct contact with the product, other relevant standards, requirements and/or regulations can be considered for the design.

STANDARD PREVIEW
(standards.iteh.ai)

2 Normative references

The following documents, in whole or in part, are normatively referenced in this document and are indispensable for its application. For dated references, only the edition cited applies. For undated references, the latest edition of the referenced document (including any amendments) applies.

EN 495-5:2013, *Flexible sheets for waterproofing — Determination of foldability at low temperature — Part 5: Plastic and rubber sheets for roof waterproofing*

EN 1109:2013, *Flexible sheets for waterproofing — Bitumen sheets for roof waterproofing — Determination of flexibility at low temperature*

EN 1110:2010, *Flexible sheets for waterproofing — Bitumen sheets for roof waterproofing — Determination of flow resistance at elevated temperature*

EN 1296:2000, *Flexible sheets for waterproofing — Bitumen, plastic and rubber sheets for roofing — Method of artificial ageing by long term exposure to elevated temperature*

EN 1427:2015, *Bitumen and bituminous binders — Determination of the softening point — Ring and Ball method*

EN 1849-1:1999, *Flexible sheets for waterproofing — Determination of thickness and mass per unit area — Part 1: Bitumen sheets for roof waterproofing*

EN 1849-2:2009, *Flexible sheets for waterproofing — Determination of thickness and mass per unit area — Part 2: Plastic and rubber sheets*

EN 12224:2000, *Geotextiles and geotextile-related products — Determination of the resistance to weathering*

EN 12225:2000, *Geotextiles and geotextile-related products — Method for determining the microbiological resistance by a soil burial test*

EN 12226:2012, *Geosynthetics — General tests for evaluation following durability testing*

EN 12310-1:1999, *Flexible sheets for waterproofing — Part 1: Bitumen sheets for waterproofing — Determination of resistance to tearing (nail shank)*

EN 12311-1:1999, *Flexible sheets for waterproofing — Part 1: Bitumen sheets for roof waterproofing — Determination of tensile properties*

EN 12311-2:2013, *Flexible sheets for waterproofing — Determination of tensile properties — Part 2: Plastic and rubber sheets for roof waterproofing*

EN 12447:2001, *Geotextiles and geotextile-related products — Screening test method for determining the resistance to hydrolysis in water*

EN 13249:2016, *Geotextiles and geotextile-related products — Characteristics required for use in the construction of roads and other trafficked areas (excluding railways and asphalt inclusion)*

EN 13250:2016, *Geotextiles and geotextile-related products — Characteristics required for use in the construction of railways*

EN 13251:2016, *Geotextiles and geotextile-related products — Characteristics required for use in earthworks, foundations and retaining structures*

EN 13252:2016, *Geotextiles and geotextile-related products — Characteristics required for use in drainage systems*

[SIST EN 15382:2018](https://standards.iteh.ai/catalog/standards/sist/19d2c2cd-2e1f-478b-bc07-100000000000/EN-15382-2018)

<https://standards.iteh.ai/catalog/standards/sist/19d2c2cd-2e1f-478b-bc07-100000000000/EN-15382-2018>

EN 13253:2016, *Geotextiles and geotextile-related products — Characteristics required for use in erosion control works (coastal protection, bank revetments)*

EN 13254:2016, *Geotextiles and geotextile-related products — Characteristics required for the use in the construction of reservoirs and dams*

EN 13255:2016, *Geotextiles and geotextile-related products — Characteristics required for use in the construction of canals*

EN 13256:2016, *Geotextiles and geotextile-related products — Characteristics required for use in the construction of tunnels and underground structures*

EN 13257:2016, *Geotextiles and geotextile-related products — Characteristics required for use in solid waste disposals*

EN 13265:2016, *Geotextiles and geotextile-related products — Characteristics required for use in liquid waste containment projects*

EN 14150:2006, *Geosynthetic barriers — Determination of permeability to liquids*

EN 14151:2010, *Geosynthetics — Determination of burst strength*

EN 14196:2016, *Geosynthetics — Test methods for measuring mass per unit area of clay geosynthetic barriers*

EN 15382:2018 (E)

EN 14414:2004, *Geosynthetics — Screening test method for determining chemical resistance for landfill applications*

EN 14415:2004, *Geosynthetic barriers — Test method for determining the resistance to leaching*

CEN/TS 14416:2014, *Geosynthetic barriers — Test method for determining the resistance to roots*

CEN/TS 14417:2014, *Geosynthetic barriers — Test method for the determination of the influence of wetting-drying cycles on the permeability of clay geosynthetic barriers*

CEN/TS 14418:2014, *Geosynthetic Barriers — Test method for the determination of the influence of freezing-thawing cycles on the permeability of clay geosynthetic barriers*

EN 14575:2005, *Geosynthetic barriers — Screening test method for determining the resistance to oxidation*

EN 14576:2005, *Geosynthetics — Test method for determining the resistance of polymeric geosynthetic barriers to environmental stress cracking*

EN 16416:2013, *Geosynthetic clay barriers — Determination of water flux index — Flexible wall permeameter method at constant head*

EN ISO 527-1:2012, *Plastics — Determination of tensile properties — Part 1: General principles (ISO 527-1:2012)*

iTeh STANDARD PREVIEW

EN ISO 527-3:1995, *Plastics — Determination of tensile properties — Part 3: Test conditions for films and sheets (ISO 527-3:1995)*

EN ISO 527-4:1997, *Plastics — Determination of tensile properties — Part 4: Test conditions for isotropic and orthotropic fibre-reinforced plastic composites (ISO 527-4:1997)*

EN ISO 1133-1:2011, *Plastics — Determination of the melt mass-flow rate (MFR) and melt volume-flow rate (MVR) of thermoplastics — Part 1: Standard method (ISO 1133-1:2011)*

EN ISO 1183-1:2012, *Plastics — Methods for determining the density of non-cellular plastics — Part 1: Immersion method, liquid pycnometer method and titration method (ISO 1183-1:2012)*

EN ISO 1183-2:2004, *Plastics — Methods for determining the density of non-cellular plastics — Part 2: Density gradient column method (ISO 1183-2:2004)*

EN ISO 1183-3:1999, *Plastics — Methods for determining the density of non-cellular plastics — Part 3: Gas pycnometer method (ISO 1183-3:1999)*

EN ISO 3696:1995, *Water for analytical laboratory use — Specification and test methods (ISO 3696:1987)*

EN ISO 9863-1:2016, *Geosynthetics — Determination of thickness at specified pressures — Part 1: Single layers (ISO 9863-1:2016)*

EN ISO 9864:2005, *Geosynthetics — Test method for the determination of mass per unit area of geotextiles and geotextile-related products (ISO 9864:2005)*

EN ISO 10318-1:2015, *Geosynthetics — Part 1: Terms and definitions (ISO 10318-1:2015)*

EN ISO 10319:2015, *Geosynthetics — Wide-width tensile test (ISO 10319:2015)*

EN ISO 11357-6:2013, *Plastics — Differential scanning calorimetry (DSC) — Part 6: Determination of oxidation induction time (isothermal OIT) and oxidation induction temperature (dynamic OIT) (ISO 11357-6:2008)*

EN ISO 12236:2006, *Geosynthetics — Static puncture test (CBR test) (ISO 12236:2006)*

EN ISO 12957-1:2005, *Geosynthetics — Determination of friction characteristics — Part 1: Direct shear test (ISO 12957-1:2005)*

EN ISO 12957-2:2005, *Geosynthetics — Determination of friction characteristics — Part 2: Inclined plane test (ISO 12957-2:2005)*

EN ISO 13438:2004, *Geotextiles and geotextile-related products — Screening test method for determining the resistance to oxidation (ISO 13438:2004)*

ISO 34-1:2015, *Rubber, vulcanized or thermoplastic — Determination of tear strength — Part 1: Trouser, angle and crescent test pieces*

ISO 11465:1993, *Soil quality — Determination of dry matter and water content on a mass basis — Gravimetric method*

ASTM D696, *Standard Test Method for Coefficient of Linear Thermal Expansion of Plastics Between -30°C and 30°C with a Vitreous Silica Dilatometer*

ASTM D4603, *Standard Test Method for Determining Inherent Viscosity of Poly(Ethylene Terephthalate) (PET) by Glass Capillary Viscometer* (standards.iteh.ai)

ASTM D5890, *Standard Test Method for Swell Index of Clay Mineral Component of Geosynthetic Clay Liners* (standards.iteh.ai)

<https://standards.iteh.ai/catalog/standards/sist/19d2c2cd-2e1f-478b-bc07-163cdde70582/sist-en-15382-2018>

ASTM D6141¹⁾, *Standard Guide for Screening Clay Portion and Index Flux of Geosynthetic Clay Liner (GCL) for Chemical Compatibility to Liquids*

ASTM D7409, *Standard Test Method for Carboxyl End Group Content of Polyethylene Terephthalate (PET) Yarns*

3 Terms, definitions and abbreviations

3.1 Terms and definitions

For the purposes of this document, the terms and definitions given in EN ISO 10318-1 and the following apply.

3.1.1

product

geosynthetic barrier, including polymeric, bituminous and clay barriers

1) <http://www.astm.org/Standards/D6141.htm>.

EN 15382:2018 (E)**3.1.2****geosynthetic barrier**

barrier with at least one of whose components is made from a synthetic or natural polymer, in the form of a sheet, a strip or a three dimensional structure, used in contact with soil and/or other materials in geotechnical and civil engineering applications

3.1.3**project specification**

document in which the works, functions, specific conditions and required material property values of the geosynthetic barrier are described

3.1.4**infrastructure**

basic transportation system that is necessary for the operation of any kind of traffic

3.1.5**embankment shoulder**

slope extending from the edge of a pavement to a linear ditch made of packed soil built above the natural ground

3.1.6**fluid**

gas, liquid and vapour in its pure phase as well as mixtures thereof

[SOURCE: EN 764-1:2015+A1:2016, 3.1.5]

STANDARD PREVIEW
(standards.iteh.ai)

3.1.7**rework material****RWM**

material that is generated in a process and capable of being reclaimed within the same process that generated it

[SOURCE: EN 13249:2016, 3.1.3]

3.1.8**post-consumer material****PCM**

material generated by households or by commercial, industrial and institutional facilities in their role as end-users of the product which can no longer be used for its intended purpose

Note 1 to entry: This includes returns of material from the distribution chain.

[SOURCE: EN 13249:2016, 3.1.4]

3.1.9**post-industrial material****PIM**

material diverted from the waste stream during a manufacturing process

[SOURCE: EN 13249:2016, 3.1.5]

3.2 Abbreviations

For the purposes of this document, the abbreviations given in EN ISO 10318-1 and the following apply.

CWFT: classification without further testing

EPDM: ethylene propylene diene monomer

EVA: ethylene vinyl acetate

FPO: flexible polyolefine

FPP: flexible polypropylene

GBR-P: polymeric geosynthetic barrier

GBR-B: bituminous geosynthetic barrier

GBR-C: clay geosynthetic barrier

HP-OIT: high pressure oxidative induction time

OIT: oxidative induction time

PE-HD: high density polyethylene

PE-LLD: linear low density polyethylene

PE-VLD: very low density polyethylene

PVC-P: flexible polyvinylchloride

4 Characteristics and corresponding methods of test

4.1 General

The main function of geosynthetic barriers for use in transportation infrastructure is to control the pathway of liquids through the construction and to limit contamination of groundwater or water sources. Damage during installation has not been addressed in this document.

4.2 Types of application

The following types of application can be distinguished:

- deep laying GBR on side slopes: application where the GBR is installed under the drainage collection system and covers the entire slope as well as the ditch area (see Figure 1);
- high laying GBR on side slopes: application where the GBR is installed above the drainage collection system as a high laying sealing system and covers the opposite side slope of the road to prevent an overflow of the road surface run-off (see Figure 2);
- deep laying GBR between two roads: application where the GBR is installed under the drainage collection system and covers the section between two roads, where a sealing is required (see Figure 3);
- high laying GBR between two roads: application where the GBR is installed above the drainage collection system as a high laying sealing system and covers the section between two roads where sealing is required (see Figure 4).

EN 15382:2018 (E)

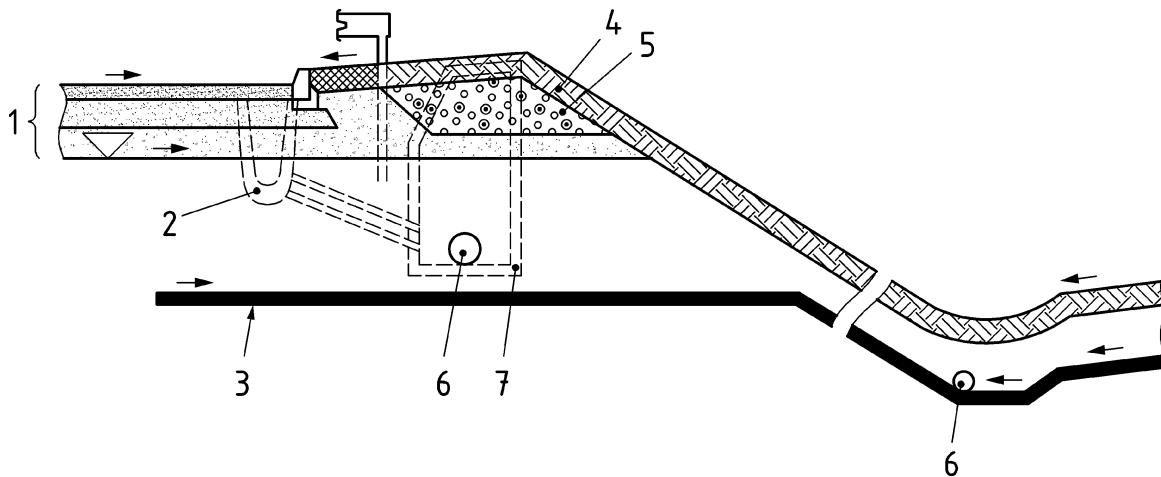
**Key**

- 1 pavement and/or track bed
- 2 rain water collection
- 3 geosynthetic barrier (GBR), with protection geosynthetic (optional)
- 4 cover soil
- 5 fill soil
- 6 collection pipe
- 7 manhole

iTeh STANDARD PREVIEW

Figure 1 — Deep GBR on side slopes

SIST EN 15382:2018

<https://standards.iteh.ai/catalog/standards/sist/f9d2c2cd-2e1f-478b-bc07-163cdde70582/sist-en-15382-2018>

163cdde70582/sist-en-15382-2018

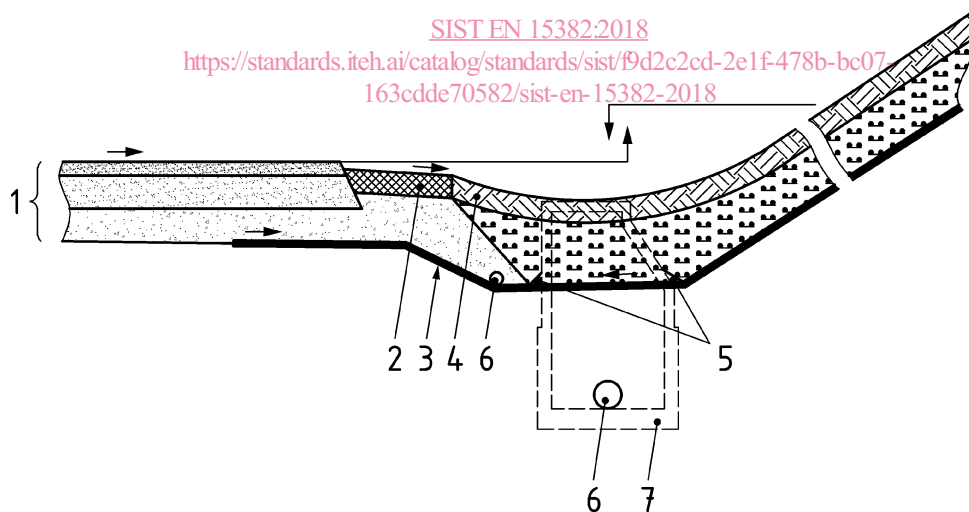
**Key**

- 1 pavement and/or track bed
- 2 side embankment
- 3 geosynthetic barrier (GBR), with protection geosynthetic (optional)
- 4 cover soil
- 5 sealing connection
- 6 collection pipe
- 7 manhole

Figure 2 — Shallow GBR on side slopes

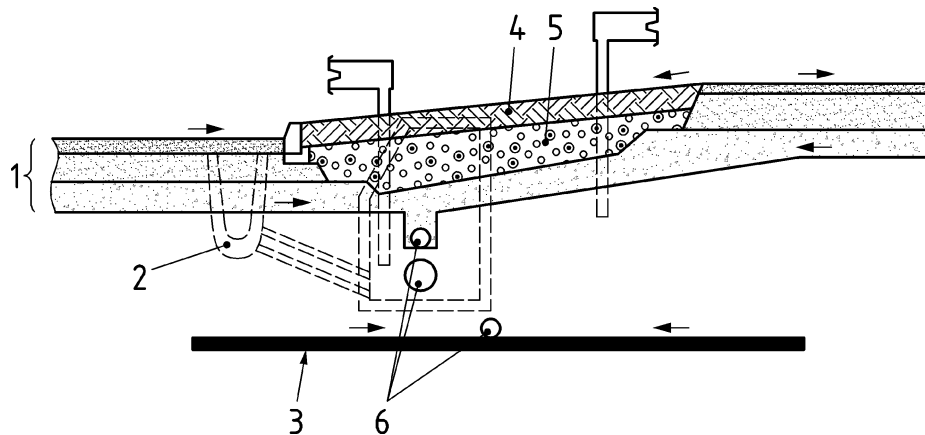
**Key**

- 1 pavement and/or track bed
- 2 rain water collection
- 3 geosynthetic barrier (GBR), with protection geosynthetic (optional)
- 4 cover soil
- 5 fill soil
- 6 collection pipe

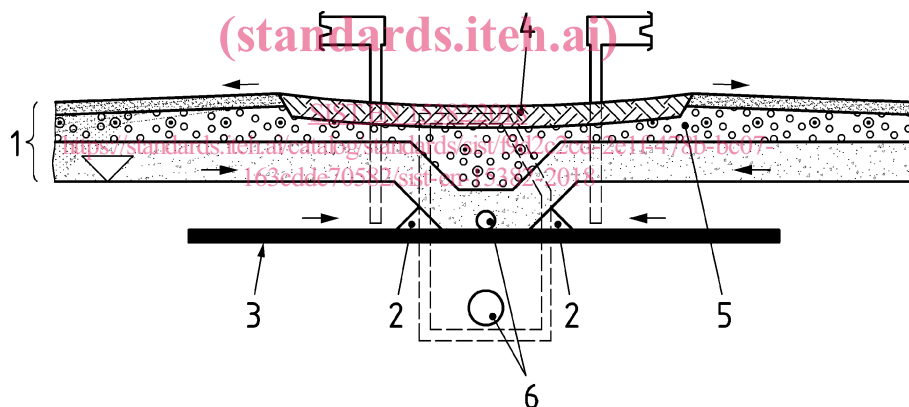
Figure 3 — Deep GBR between two roads**Key**

- 1 pavement and/or track bed
- 2 sealing connection
- 3 geosynthetic barrier (GBR), with protection geosynthetic (optional)
- 4 cover soil
- 5 fill soil
- 6 collection pipe

Figure 4 — Shallow GBR between two roads**4.3 Relevant characteristics**

The characteristics, their relevance to the conditions of use, and the test methods to be used, are specified in Table 1. The list of characteristics in Table 1 includes those relevant to all conditions of use (A) (essential characteristics are listed in Table ZA.1), and those relevant to specific conditions of use (S). The indication “-” means that the characteristic is not relevant for that function.