



**SLOVENSKI STANDARD**  
**SIST EN 301 126-3-1 V1.1.1:2003**  
**01-december-2003**

---

: ]\_gb]`fUX]`g\_]`g]ghYa ]`È`DfYg\_i`ýUb`Y`g\_`UXbcgh]`È` !%`XY.`5 bhYbY`hjdUhc`\_U!hc`\_U`  
È`8 YZ]b]W]Y`Zgd`c`ýbY`nU` hYj`Y]b`dfYg\_i`gb]`dcghcd\_]`

Fixed Radio Systems; Conformance testing; Part 3-1: Point-to-Point antennas;  
Definitions, general requirements and test procedures

**iteh STANDARD PREVIEW**  
**(standards.iteh.ai)**

Ta slovenski standard je istoveten z: **EN 301 126-3-1 Version 1.1.1**

SIST EN 301 126-3-1 V1.1.1:2003  
<https://standards.iteh.ai/catalog/standards/sis/59d07531-0ccc-402d-b348-54da64dca922/sist-en-301-126-3-1-v1-1-1-2003>

---

**ICS:**

33.060.30	Radiorelejni in fiksni satelitski komunikacijski sistemi	Radio relay and fixed satellite communications systems
33.120.40	Antene	Aerials

**SIST EN 301 126-3-1 V1.1.1:2003**      **en**

**iTeh STANDARD PREVIEW**  
**(standards.iteh.ai)**

[SIST EN 301 126-3-1 V1.1.1:2003](https://standards.iteh.ai/catalog/standards/sist/59d07331-0ccc-402d-b348-54da64dca922/sist-en-301-126-3-1-v1-1-1-2003)

<https://standards.iteh.ai/catalog/standards/sist/59d07331-0ccc-402d-b348-54da64dca922/sist-en-301-126-3-1-v1-1-1-2003>

# ETSI EN 301 126-3-1 V1.1.1 (2000-04)

---

*European Standard (Telecommunications series)*

## **Fixed Radio Systems; Conformance testing; Part 3-1: Point-to-Point antennas; Definitions, general requirements and test procedures**

---

**iTeh STANDARD PREVIEW**  
**(standards.iteh.ai)**

[SIST EN 301 126-3-1 V1.1.1:2003](https://standards.iteh.ai/catalog/standards/sist/59d07331-0ccc-402d-b348-54da64dca922/sist-en-301-126-3-1-v1-1-1-2003)

<https://standards.iteh.ai/catalog/standards/sist/59d07331-0ccc-402d-b348-54da64dca922/sist-en-301-126-3-1-v1-1-1-2003>



---

**Reference**

DEN/TM-04026-3-1

---

**Keywords**antenna, architecture, DRRS, SDH, testing,  
transmission, point-to-point**ETSI**

---

**Postal address**

F-06921 Sophia Antipolis Cedex - FRANCE

---

**Office address**650 Route des Lucioles - Sophia Antipolis  
Valbonne - FRANCE

Tel.: +33 4 92 94 42 00 Fax: +33 4 93 65 47 16

Siret N° 348 623 562 00017 - NAF 742 C

Association à but non lucratif enregistrée à la  
Sous-Prefecture de Grasse (06) N° 7803/88

---

**Internet**

secretariat@etsi.fr

Individual copies of this ETSI deliverable  
can be downloaded from<http://www.etsi.org>If you find errors in the present document, send your  
comment to: editor@etsi.fr

---

**Important notice**

This ETSI deliverable may be made available in more than one electronic version or in print. In any case of existing or perceived difference in contents between such versions, the reference version is the Portable Document Format (PDF).

In case of dispute, the reference shall be the printing on ETSI printers of the PDF version kept on a specific network drive within ETSI Secretariat.

---

**Copyright Notification**

No part may be reproduced except as authorized by written permission.  
The copyright and the foregoing restriction extend to reproduction in all media.

© European Telecommunications Standards Institute 2000.  
All rights reserved.

# Contents

Intellectual Property Rights.....	5
Foreword .....	5
1 Scope.....	6
2 References.....	6
3 Definitions, symbols and abbreviations .....	7
3.1 Definitions .....	7
3.2 Symbols.....	8
3.3 Abbreviations .....	8
4 Requirements related to Antenna conformance testing .....	8
4.1 General requirements.....	8
4.2 Implementation under test (IUT).....	10
5 Suppliers declaration.....	10
5.1 General characteristics.....	10
5.1.1 Frequency range(s) .....	10
5.1.1.1 Frequency Band(s) .....	10
5.1.2 Class of antenna RPE.....	10
5.1.3 Antenna XPD category .....	10
5.1.4 Gain category.....	10
5.1.5 Environmental Characteristics .....	10
5.1.6 Antenna stability.....	11
5.1.7 Antenna input connector.....	11
5.1.8 Return loss/VSWR.....	11
5.1.9 Inter-port isolation .....	11
6 Test procedures for essential requirements.....	11
6.1 Radiation pattern envelope (RPE).....	11
6.1.1 Objective.....	11
6.1.2 Test instruments and set-up.....	11
6.1.3 Test procedure .....	12
6.1.4 Test procedure example (alternative test procedures could be used).....	12
6.2 Antenna cross-polar discrimination (XPD) .....	12
6.2.1 Objective.....	12
6.2.2 Test instruments and set-up.....	13
6.2.3 Test procedure .....	13
6.2.4 Test procedure example .....	13
6.2.5 Test procedure example .....	14
6.3 Antenna gain.....	15
6.3.1 Objective.....	15
6.3.2 Test instruments and set-up.....	15
6.3.3 Test procedure .....	17
<b>Annex A (normative):      Supplier's declaration .....</b>	<b>18</b>
A.1 Suppliers Declaration.....	18
A.1.1 Suppliers Declaration against the Essential Parameters .....	18
A.1.2 Suppliers Declaration against the Complementary/Optional Parameters .....	19
A.1.2.1 Environmental characteristics .....	19
A.1.2.1.1 Temperature range .....	19
A.1.2.1.2 Wind survival.....	19
A.1.2.2 Antenna stability.....	20
A.1.2.3 Antenna input connectors.....	20
A.1.2.4 Return loss / VSWR.....	20
A.1.2.5 Inter-port isolation .....	20

<b>Annex B (normative):</b>	<b>Test report .....</b>	<b>21</b>
B.1	Test results .....	21
B.1.1	Summary of tests .....	21
B.1.2	General information about the tests .....	22
B.1.3	Test result forms .....	22
B.1.3.1	Radiation Pattern Envelope (RPE).....	22
B.1.3.1.1	Co-polar radiation patterns.....	22
B.1.3.1.2	Cross-polar radiation patterns .....	23
B.1.3.2	Antenna cross-polar discrimination (XPD).....	24
B.1.3.3	Antenna gain .....	24
B.1.3.4	Environmental conditions during the test.....	25
B.1.4	Measurement Accuracy .....	25
B.1.4.1	Gain measurement accuracy .....	25
B.1.4.2	Co-polar, cross-polar radiation patterns and antenna XPD measurement accuracy.....	25
B.2	Test equipment used for tests.....	26
B.3	Supplementary information.....	27
B.4	Test site details.....	27
B.4.1	Example of test site description.....	27
	Bibliography .....	29
	History .....	30

## iTeh STANDARD PREVIEW (standards.iteh.ai)

[SIST EN 301 126-3-1 V1.1.1:2003](https://standards.iteh.ai/catalog/standards/sist/59d07331-0ccc-402d-b348-54da64dca922/sist-en-301-126-3-1-v1-1-1-2003)

<https://standards.iteh.ai/catalog/standards/sist/59d07331-0ccc-402d-b348-54da64dca922/sist-en-301-126-3-1-v1-1-1-2003>

## Intellectual Property Rights

IPRs essential or potentially essential to the present document may have been declared to ETSI. The information pertaining to these essential IPRs, if any, is publicly available for **ETSI members and non-members**, and can be found in SR 000 314: *"Intellectual Property Rights (IPRs); Essential, or potentially Essential, IPRs notified to ETSI in respect of ETSI standards"*, which is available from the ETSI Secretariat. Latest updates are available on the ETSI Web server (<http://www.etsi.org/ipr>).

Pursuant to the ETSI IPR Policy, no investigation, including IPR searches, has been carried out by ETSI. No guarantee can be given as to the existence of other IPRs not referenced in SR 000 314 (or the updates on the ETSI Web server) which are, or may be, or may become, essential to the present document.

## Foreword

This European Standard (Telecommunications series) has been produced by ETSI Technical Committee Transmission and Multiplexing (TM).

The present document defines the type approval testing requirements for the antenna specific parameters, required directly by the relevant radio relay or antenna standard. Harmonized test methods and test report format, for these parameters, are also contained, herein.

In addition to the main body of the present document there are two annexes, namely the Supplier Declaration (annex A) and the Test Report (annex B). The parameters in the two annexes are according to the main body of the present document.

The present document is part 3, sub-part 1 of a multi-part EN covering the Fixed Radio System; Conformance testing, as identified below:

Part 1: "Point-to-Point equipment; Definitions, general requirements and test procedures";

Part 2-1: "Point-to-Multipoint equipment; Definitions and general requirements";

Part 2-2: "Point-to-Multipoint equipment; Test procedures for FDMA systems";

Part 2-3: "Point-to-Multipoint equipment; Test procedures for TDMA systems";

Part 2-4: "Point-to-Multipoint equipment; Test procedures for FH-CDMA systems";

Part 2-5: "Point-to-Multipoint equipment; Test procedures for DS-SS-CDMA systems";

**Part 3-1: "Point-to-Point antennas; Definitions, general requirements and test procedures";**

Part 3-2: "Point-to-Multipoint antennas; Definitions, general requirements and test procedures".

### National transposition dates

Date of adoption of this EN:	24 March 2000
Date of latest announcement of this EN (doa):	30 June 2000
Date of latest publication of new National Standard or endorsement of this EN (dop/e):	31 December 2000
Date of withdrawal of any conflicting National Standard (dow):	31 December 2000

## 1 Scope

The present document details standardized procedures for conformance testing of antennas for point-to-point radio relay systems [1] in order to achieve the approval by the Type Approval Authority.

The procedure for dealing with established products are outside the scope of the present document.

Standardized procedures are required in order to fulfill CEPT/ERC/DEC/(97) 10 [2] on the mutual recognition, within CEPT, of conformance test of antennas carried out in individual CEPT Countries.

The present document is intended to be applied in conjunction with the individual antenna standards and will enable commonality in the presentation of test results, irrespective of the Suppliers/accredited laboratory carrying out the test.

NOTE: The recent draft Directive by the EEC [97-149 (COD)] and parallel work within CEPT ERC on mutual recognition, proposes that type approval against essential requirements can be carried out at manufacturers or third party premises. The level of accreditation required needs to be clarified by CEPT.

The conformance tests described in the present document are related to antenna specific parameters required directly by the relevant antenna standards.

Integrated antennas which can not be separated from the equipment are not covered by the present document.

## 2 References

The following documents contain provisions which, through reference in this text, constitute provisions of the present document.

- References are either specific (identified by date of publication, edition number, version number, etc.) or non-specific.
- For a specific reference, subsequent revisions do not apply.
- For a non-specific reference, the latest version applies.
- A non-specific reference to an ETS shall also be taken to refer to later versions published as an EN with the same number.

- [1] ETSI EN 300 833: "Fixed Radio Systems; Point to Point Antennas; Antennas for point-to-point fixed radio systems operating in the frequency band 3 GHz to 60 GHz".
- [2] CEPT/ERC/DEC/(97) 10: "On the mutual recognition of conformity assessment procedures including marking of radio equipment an radio terminal equipment".
- [3] ISO/IEC Guide 25 (1990): "General requirements for the competence of calibration and testing laboratories".
- [4] ISO/IEC Guide 28 (1982): "General rules for a model third-party certification system for product".
- [5] EN 45001 (1989): "General criteria for the operation of testing laboratories".
- [6] EN 45002 (1989): "General criteria for the assessment of testing laboratories".
- [7] ISO 9001 (1994): "Quality systems; Model for quality assurance in design, development, production, installation and servicing".
- [8] IEC 835-2-2 (1994): "Methods of measurement for equipment used in digital microwave transmission systems; Part 2: Measurements on terrestrial radio-relay systems; Section 2: Antenna".
- [9] 1999/5/EC: "On radio equipment and telecommunication terminal equipment and the mutual recognition of their conformity".



- [10] IEC 154: "Information technology; Data interchange on 90 mm optical disk cartridges; HS-1 format; Capacity: 650 Mbytes per cartridge".
- [11] IEC 169: "Radio-frequency connectors".

---

## 3 Definitions, symbols and abbreviations

### 3.1 Definitions

For the purposes of the present document, the following terms and definitions apply:

**accreditation:** formal recognition that a testing laboratory is competent to carry out specific tests or specific types of test.

**accreditation body:** body that conducts and administers a laboratory accreditation system and grants accreditation.

**accreditation system:** system that has its own rules of procedure and management for carrying out laboratory accreditation.

**accredited laboratory:** testing laboratory which accreditation has been granted in accordance with the ISO/IEC guides 25 [3] and 28 [4] or EN 45001 [5] and EN 45002 [6].

**antenna:** that part of the transmitting or receiving system that is designed to radiate and/or receive electromagnetic waves.

**approval testing:** approval of the Implementation Under Test (IUT) by the appropriate authority for regulatory purposes. In this context approval implies that the IUT has met the essential requirements of the standard against which it has been tested.

**Complementary Requirements (CR):** all those requirements not part of the essential requirements are complementary requirements.

**conformance testing:** process to verify to what extent the IUT conforms to the standard.

**essential requirements:** basic set of parameters and functions which are necessary to meet any regulatory obligations imposed for radio frequency co-ordination.

**Implementation Under Test (IUT):** representative sample of the equipment for Conformance Testing.

**Optional Requirements (OR):** used in a standard with two different meanings:

- 1) optional in the sense that the parameter or function itself is mandatory but there is more than one possible value or configuration which may be chosen (e.g. class of Antenna RPE, frequency band(s), etc.). Once an option is selected it becomes mandatory;
- 2) optional in the sense that the feature is not mandatory (e.g. antenna input connector etc.). However, once such an option has been implemented it becomes mandatory that it conforms to the requirements of the present document.

**Supplier:** organization requesting the approval.

**Supplier's Declaration (SD):** procedure by which a supplier gives written assurance that a parameter or function conforms to the present document.

**Type Approval Authority:** national Regulatory/Licensing Authority.

## 3.2 Symbols

For the purposes of the present document, the following symbol applies:

dB                      decibel

## 3.3 Abbreviations

For the purposes of the present document, the following abbreviations apply:

CR	Complementary Requirement
ER	Essential Requirement
Ext	Extreme conditions
IUT	Implementation Under Test
OR	Optional Requirement
Ref	Reference conditions
RF	Radio Frequency
SD	Supplier's Declaration
TR	Test Required
RPE	Radiation Pattern Envelope
VSWR	Voltage Standing Wave Retro
XPD	Antenna Cross-Polar Discrimination

---

# 4 Requirements related to Antenna conformance testing

## 4.1 General requirements

<https://standards.iteh.ai/catalog/standards/sist/59d07331-0ccc-402d-b348-54b1e1a92311/sist/301-126-3-1-v1.1.1-2003>

In table 1 the generic clauses and parameters are classified, for conformance testing purposes, in terms of the various categories.

Table 1: 'Generic requirements' classification

Function or Parameter Description	Status for conformance			Requirement for conformance testing			Power supply conditions		Climatic conditions for test		Limiting values	Test methods	
	ER	CR	OR	SD	TR	SD <sup>3</sup> + TR	Ref	Ref + Ext	Ref. (note 1)	Ref + Ext.		Clause Ref.	IEC 835-2-2 [8] or other Ref. (note 2)
Frequency range		X	X	X (note 3)									
Frequency band(s)		X	X	X <sup>3</sup>									
Class of antenna RPE		X	X	X <sup>3</sup>									
Radiation pattern envelope (RPE)	X		X			X			X				IEC 835-2-2 [8]
Antenna cross-polar discrimination (XPD)	X		X			X			X				IEC 835-2-2 [8]
Antenna gain	X		X			X			X				IEC 835-2-2 [8]
Environmental characteristics		X	X	X									
Antenna stability		X	X	X									
Antenna input connectors		X	X	X									
Return loss / VSWR		X		X									IEC 835-2-2 [8]
Inter-port isolation		X	X	X									IEC 835-2-2 [8]
NOTE 1: The environmental conditions at the time of test shall be recorded in the Test Report. This declaration will also guarantee that the essential requirements shall be met for the environmental conditions given in subclause 5.1.5 and subclause 5.1.6.													
NOTE 2: Alternative test methods may be agreed prior to testing.													
NOTE 3: SD is intended for proper selection among provided options or for information necessary to carry out the Test.													

Clear distinction is made between "Essential Requirements (ER)" which require "Approval Testing" for regulatory purpose and "Complementary Requirements (CR) or Optional Requirements (OR)" which fulfill the "Conformance Testing" against the relevant standards.

The Type Approval Authority shall require the Supplier's declaration which encompasses the test report demonstrating essential requirements (radiation pattern, antenna cross polar discrimination and gain), accompanied by evidence of accreditation to an internationally recognized Quality Standard, at least ISO 9001 [7].

The supplier shall be considered legally responsible for any statement in the declaration.

Annex A contains the Suppliers Declaration template for all the parameters in table 1. Annex B contains the Test Report template for the essential requirements listed in table 1.

Test Methods shall be adopted in accordance with IEC 835-2-2 [8], although suitable test methods may be agreed between the Supplier and the Type Approval Authority, prior to testing. A description of the test method is to be included in the test report.

## 4.2 Implementation under test (IUT)

The IUT presented for Type approval shall be a representative production model.

Testing shall be conducted at point D (D') in figure 1. An appropriate adapter shall be used if required to connect the antenna at point D (D') to the test equipment and the effects of the adapter upon the test results shall be taken into account and declared.

The configuration used during the test shall be provided in the test report clearly indicating point D (D').

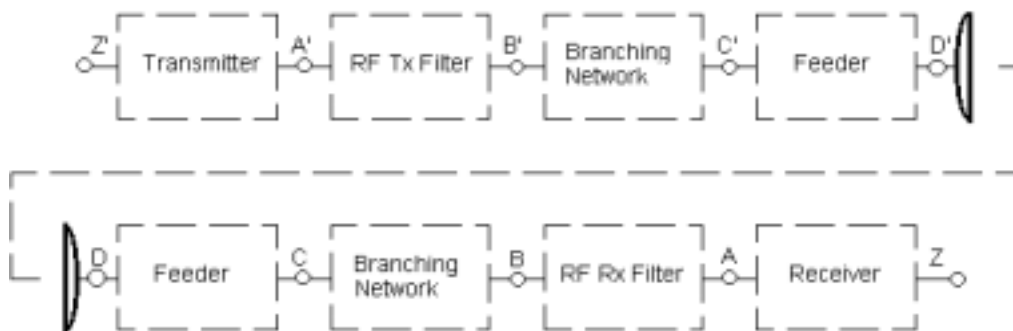

Figure 1: System block diagram

## 5 Suppliers declaration

### 5.1 General characteristics

#### 5.1.1 Frequency range(s)

The frequency range(s) from those quoted in the relevant standard shall be stated.

##### 5.1.1.1 Frequency Band(s)

The operational frequency band(s) of the antenna shall be stated and measurements shall be carried out as a minimum at the lowest, middle and highest frequency of (each of) the relevant band(s).

##### 5.1.2 Class of antenna RPE

The class of antenna RPE from within the declared frequency range of the relevant antenna standard shall be stated.

##### 5.1.3 Antenna XPD category

The XPD category of the antenna from within the declared frequency range of the relevant antenna standard shall be stated.

##### 5.1.4 Gain category

The gain category from within the declared frequency range of the relevant antenna standard shall be stated.

##### 5.1.5 Environmental Characteristics

The supplier shall declare the temperature range and the wind survival rating of the antenna. Guidance information on antenna environmental characteristics may be found in the relevant antenna standard.