



Standard Test Method for Copper Strip Corrosion by Liquefied Petroleum (LP) Gases¹

This standard is issued under the fixed designation D 1838; the number immediately following the designation indicates the year of original adoption or, in the case of revision, the year of last revision. A number in parentheses indicates the year of last reapproval. A superscript epsilon (ϵ) indicates an editorial change since the last revision or reapproval.

1. Scope*

1.1 This test method detects the presence of components in liquefied petroleum gases which may be corrosive to copper.

NOTE 1—For an equivalent copper strip test applicable to less volatile petroleum products, see Test Method D 130.

1.2 The values stated in SI units are to be regarded as the standard. The values given in parentheses are for information only.

1.3 *This standard does not purport to address all of the safety concerns, if any, associated with its use. It is the responsibility of the user of this standard to establish appropriate safety and health practices and determine the applicability of regulatory limitations prior to use. For specific warning statements, see 6.1, 8.3.1, and Annex A1.*

2. Referenced Documents

2.1 *ASTM Standards:*²

D 130 Test Method for Corrosiveness to Copper from Petroleum Products by Copper Strip Test

E 1 Specification for ASTM Liquid-in-Glass Thermometers

2.2 *ASTM Adjuncts:*

ADJD0130, ASTM Copper Strip Corrosion Standard for Petroleum³

3. Summary of Test Method

3.1 A polished copper strip is immersed in approximately 100 mL of the sample and exposed at a temperature of 37.8°C (100°F) for 1 h in a cylinder of suitable working pressure. At the end of this period, the copper strip is removed and rated as one of the four classifications of the ASTM Copper Corrosion Standards.

¹ This test method is under the jurisdiction of ASTM Committee D02 on Petroleum Products and Lubricants and is the direct responsibility of Subcommittee D02.H0 on Liquefied Petroleum Gas.

Current edition approved May 1, 2005. Published May 2005. Originally approved in 1961. Last previous edition D 1838–03.

² For referenced ASTM standards, visit the ASTM website, www.astm.org, or contact ASTM Customer Service at service@astm.org. For *Annual Book of ASTM Standards* volume information, refer to the standard's Document Summary page on the ASTM website.

³ Available from ASTM International Headquarters. Order Adjunct No. ADJD0130.

4. Significance and Use

4.1 Copper corrosion limits provide assurance that difficulties will not be experienced in deterioration of the copper and copper-alloy fittings and connections that are commonly used in many types of utilization, storage, and transportation equipment.

5. Apparatus

5.1 *Corrosion Test Cylinder*, constructed of stainless steel with an O-ring removable top closure according to the dimensions given in Fig. 1. Provide a flexible inert hose, such as one composed of aluminum or stainless steel, which permits inverting the test cylinder as required in the procedure (see Note 2). The whole assembly shall be capable of withstanding a hydrostatic test pressure of 6895 kPa (1000 psig). No leak shall be discernible when tested at 3450 kPa (500 psig) with gas.

NOTE 2—Swivel connections with an adapter to fit a 6.4 mm (¼ in.) pipe may be used.

5.2 *Water Bath*, capable of being maintained at 37.8 ± 0.5°C (100 ± 1°F). Incorporate suitable supports to hold the test cylinder in an upright position. Make the bath deep enough so that the entire cylinder and valves will be covered during the test.

5.3 *Temperature Sensing Device (TSD)*—Capable of monitoring the desired test temperature in the bath to within an accuracy of ±0.5°C (1°F) or better. The ASTM 12C (12F) total immersion thermometer has been found suitable to use in the test (see Specification E 1). If used, no more than 25 mm (1 in.) of the mercury should extend above the surface of the bath at the test temperature.

5.4 *Strip Polishing Vise*, to hold the copper strip firmly without marring the edges. For convenient vises see Test Method D 130.

6. Materials

6.1 *Wash Solvent*—Use acetone or knock test grade 2.2.4 trimethylpentane. (**Warning**—Extremely flammable. See Annex A1.)

6.2 *Copper Strip*, approximately 12.5 mm (½ in.) wide, 1.5 to 3.0 mm (⅛ to ¼ in.) thick, cut approximately 75 mm (3 in.) long from smooth-surfaced, hard-temper, cold-finished

*A Summary of Changes section appears at the end of this standard.

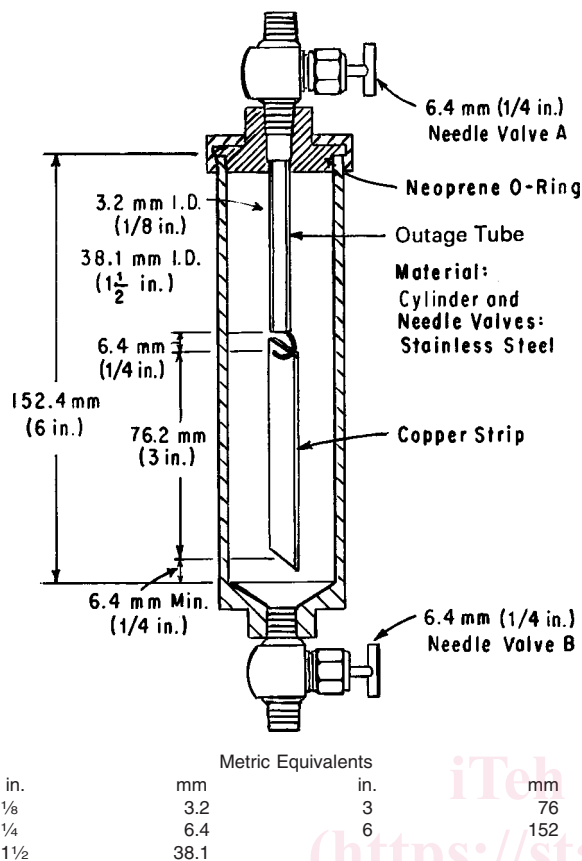

FIG. 1 Copper Strip Corrosion Test Cylinder

copper of 99.9 + % purity; electrical bus bar stock is generally suitable. Drill a 3.2 mm (1/8 in.) hole approximately 3.2 mm (1/8 in.) from one end in the center of the strip. The strips may be used repeatedly but should be discarded if surfaces become deformed.

6.3 *Surface Preparation/Polishing Materials*—00 grade or finer steel wool; silicon carbide grit paper or cloth of varying degrees of fineness including 65- μ m (240-grit) grade; also a supply of 105- μ m (150-mesh) size silicon carbide grain or powder and absorbent cotton. A commercial grade is suitable, but pharmaceutical grade cotton wool is most commonly available and is acceptable.

6.4 *Copper Corrosion Standard Plaques* are available.³ Their care and inspection for stability are described in detail in Test Method D 130.

7. Preparation of Strips

7.1 *Surface Preparation*—Remove all surface blemishes from all six sides of the strip obtained from a previous analysis. One way to accomplish this is to use 00 grade or finer steel wool or silicon carbide paper or cloth of such degrees of fineness as are needed to accomplish the desired results efficiently. Finish with 65- μ m (240-grit) silicon carbide paper or cloth, removing all marks that may have been made by other grades of paper used previously. Ensure the prepared copper strip is protected from oxidation prior to final preparation, such as by immersing the strip in wash solvent from which it can be withdrawn immediately for finish preparation (polishing) or in which it can be stored for future use.

7.1.1 As a practical manual procedure for surface preparation, a sheet of silicon carbide paper may be placed on a flat surface and then moisten the paper with wash solvent before rubbing the strip against the silicon carbide paper or cloth with a circular motion. Protect the strip from contact with the fingers, such as by using ashless filter paper. Alternatively, the surface of the strip can be prepared by use of motor-driven machines using appropriate grades of dry paper or cloth.

7.2 *Final Preparation*—For strips prepared in 7.1 or new strips being used for the first time, remove a strip from its protected location, such as by removing it from the wash solvent. Polish first the ends and then the sides with the 105- μ m (150- μ m mesh) silicon carbide grains picked up with a pad of absorbent cotton moistened with wash solvent, making sure that the surface is protected from coming in contact with the fingers, such as by using ashless filter paper. Wipe vigorously with fresh pads of absorbent cotton and subsequently handle without touching the surface of the strip with the fingers. Padded forceps (to prevent the scratching of the surface) have been found suitable to use. Secure the copper strip in a vise or suitable holder and polish the main surfaces with silicon-carbide grains on absorbent cotton. Do not polish in a circular motion. Rub in the direction of the long axis of the strip, carrying the stroke beyond the end of the strip before reversing the direction. Clean all metal dust from the strip by rubbing vigorously with clean pads of absorbent cotton until a fresh pad remains unsoiled. When the strip is clean, with minimal delay, attach to the dip tube and lower into the prepared corrosion test cylinder (see Fig. 1).

7.2.1 It is important to polish the whole surface of the strip uniformly to obtain a uniformly stained strip. If the edges show wear (surface elliptical) they will likely show more corrosion than the center. The use of a vise will facilitate uniform polishing.

7.2.2 It is important to follow the order of preparation with the correctly sized silicon carbide material as described in 7.1 and 7.2. The final preparation is with 105- μ m silicon carbide grain. This is a larger grain size than the 65- μ m paper used in the surface preparation stage. The reason for this use of larger silicon carbide grains in the final preparation is to produce asperities (controlled roughness) on the surface of the copper, which acts as sites for the initiation of corrosion reactions.

8. Procedure

8.1 With valve B (Fig. 1), open, place approximately 1 mL of distilled water into a clean test cylinder and swirl to moisten the walls; allow the remainder to drain from the cylinder, insert the freshly polished copper strip suspended from the hook on the dip tube making sure that the bottom of the strip is at least 6.4 mm (1/4 in.) from the bottom of the cylinder when assembled. After assembly of the apparatus, close both valve A (Fig. 1), on closure assembly with outgassing tube, and valve B.

8.2 Holding the test cylinder upright so as not to wet the copper strip with water, attach the sample source to the test cylinder valve A (Fig. 1) by means of a short length of flexible inert hose that has been purged with the sample. Admit some sample to the cylinder by opening the valve at the sample source and then valve A.