Plastics — Methods for marine exposure

Plastiques — Méthodes d'exposition aux intempéries marines

iTeh STANDARD PREVIEW
(standards.iteh.ai)

ISO 15314:2004

<https://standards.iteh.ai/catalog/standards/sist/1bef1bc6-c77e-4539-a66b-35f7c9103558/iso-15314-2004>



PDF disclaimer

This PDF file may contain embedded typefaces. In accordance with Adobe's licensing policy, this file may be printed or viewed but shall not be edited unless the typefaces which are embedded are licensed to and installed on the computer performing the editing. In downloading this file, parties accept therein the responsibility of not infringing Adobe's licensing policy. The ISO Central Secretariat accepts no liability in this area.

Adobe is a trademark of Adobe Systems Incorporated.

Details of the software products used to create this PDF file can be found in the General Info relative to the file; the PDF-creation parameters were optimized for printing. Every care has been taken to ensure that the file is suitable for use by ISO member bodies. In the unlikely event that a problem relating to it is found, please inform the Central Secretariat at the address given below.

iTeh STANDARD PREVIEW
(standards.iteh.ai)

ISO 15314:2004

<https://standards.iteh.ai/catalog/standards/sist/1bef1bc6-c77e-4539-a66b-35f7c9103558/iso-15314-2004>

© ISO 2004

All rights reserved. Unless otherwise specified, no part of this publication may be reproduced or utilized in any form or by any means, electronic or mechanical, including photocopying and microfilm, without permission in writing from either ISO at the address below or ISO's member body in the country of the requester.

ISO copyright office
Case postale 56 • CH-1211 Geneva 20
Tel. + 41 22 749 01 11
Fax + 41 22 749 09 47
E-mail copyright@iso.org
Web www.iso.org

Published in Switzerland

Contents

	Page
1 Scope	1
2 Normative references	1
3 Terms and definitions	2
4 Principle	2
4.1 General	2
4.2 Significance	2
5 Requirements for apparatus	3
5.1 General requirements	3
5.2 Requirements for method A, floating exposure	3
5.3 Requirements for method B, partial-immersion exposure	4
5.4 Requirements for method C, shallow-immersion exposure	5
6 Test specimens	5
6.1 Form and preparation	5
6.2 Number of test specimens	7
6.3 Storage and conditioning	8
7 Procedure	8
7.1 General	8
7.2 Specific procedure for method A, marine floating exposure	8
7.3 Specific procedure for method B, partial-immersion exposure	9
7.4 Specific procedure for method C, shallow-immersion exposure	9
7.5 Evaluation of specimens after exposure	9
8 Test report	10
Bibliography	12

Foreword

ISO (the International Organization for Standardization) is a worldwide federation of national standards bodies (ISO member bodies). The work of preparing International Standards is normally carried out through ISO technical committees. Each member body interested in a subject for which a technical committee has been established has the right to be represented on that committee. International organizations, governmental and non-governmental, in liaison with ISO, also take part in the work. ISO collaborates closely with the International Electrotechnical Commission (IEC) on all matters of electrotechnical standardization.

International Standards are drafted in accordance with the rules given in the ISO/IEC Directives, Part 2.

The main task of technical committees is to prepare International Standards. Draft International Standards adopted by the technical committees are circulated to the member bodies for voting. Publication as an International Standard requires approval by at least 75 % of the member bodies casting a vote.

Attention is drawn to the possibility that some of the elements of this document may be the subject of patent rights. ISO shall not be held responsible for identifying any or all such patent rights.

ISO 15314 was prepared by Technical Committee ISO/TC 61, *Plastics*, Subcommittee SC 6, *Ageing, chemical and environmental resistance*.

iTeh STANDARD PREVIEW (standards.iteh.ai)

[ISO 15314:2004](https://standards.iteh.ai/catalog/standards/sist/1bef1bc6-c77e-4539-a66b-35f7c9103558/iso-15314-2004)

<https://standards.iteh.ai/catalog/standards/sist/1bef1bc6-c77e-4539-a66b-35f7c9103558/iso-15314-2004>

Introduction

Plastics are often used in outdoor applications where they are immersed or partially immersed in water. In some cases, materials made from plastic are designed to float on water. In others, plastic articles that are discarded end up as floating debris. In addition to the effects of sunlight and heat, plastic polymers or products exposed in marine environments may be subjected to hydrolysis, water absorption, extraction of stabilizers, erosion by wave action, corrosion by salts and/or attack by seaborne microorganisms. These stresses are not simulated in typical weathering exposures conducted in accordance with ISO 877. Therefore a separate standard is necessary to define procedures that realistically and consistently stress plastic materials in the same way that they would be in products used or discarded in marine environments. This International Standard describes three procedures for the exposure of plastic materials in the same way as they could be when used in marine environments.

There are four primary reasons why the rate of degradation of plastics exposed at sea can be different from that for the same plastic exposed on land^[1]:

- a) exposure in moist conditions is known to accelerate degradation of some polymers — small amounts of absorbed water may act as a plasticizer, increasing accessibility of the matrix to oxygen, or may leach out stabilizing additives;
- b) differences in heat build-up between plastics exposed in water or on the surface compared to plastics exposed on land;
- c) the action of microorganisms that may shield the plastic from UV radiation or may enhance biodegradation processes;
- d) the action of macroorganism settlements that can produce disfigurement of surfaces.

It is essential to establish appropriate exposure procedures in order to properly assess the performance of plastics used in marine environments, and to evaluate how long plastics discarded as litter will persist in marine environments.

iTeh STANDARD PREVIEW
(standards.iteh.ai)

ISO 15314:2004

<https://standards.iteh.ai/catalog/standards/sist/1bef1bc6-c77e-4539-a66b-35f7c9103558/iso-15314-2004>

Plastics — Methods for marine exposure

1 Scope

This International Standard describes three methods for the exposure of plastics in a marine environment. Method A covers exposures where specimens float on the surface, method B covers exposures where specimens are partially immersed and method C covers exposures where specimens are completely immersed. Although intended for marine (salt water) exposure, the methodology might be used with outdoor brackish water and fresh-water exposures as well. Direct weathering of plastics on land is described in ISO 877.

Method A is particularly applicable to enhanced-degradability plastics where the environmental degradation under marine floating exposure is expected to be accelerated relative to that of regular plastic materials.

This International Standard specifies the general requirements for the apparatus, and procedures for using the test methods described.

It lists properties that may be used to evaluate changes in plastics subjected to marine exposure. More specific information about methods for determining the changes in properties of plastics on exposure and reporting these results is given in ISO 4582.

2 Normative references

ISO 15314:2004

<https://standards.iteh.ai/catalog/standards/sist/1bef1bc6-c77e-4539-a66b-357e91038814/iso-15314-2004>

The following referenced documents are indispensable for the application of this document. For dated references, only the edition cited applies. For undated references, the latest edition of the referenced document (including any amendments) applies.

ISO 291, *Plastics — Standard atmospheres for conditioning and testing*

ISO 293, *Plastics — Compression moulding of test specimens of thermoplastic materials*

ISO 294-1, *Plastics — Injection moulding of test specimens of thermoplastic materials — Part 1: General principles, and moulding of multipurpose and bar test specimens*

ISO 294-2, *Plastics — Injection moulding of test specimens of thermoplastic materials — Part 2: Small tensile bars*

ISO 294-3, *Plastics — Injection moulding of test specimens of thermoplastic materials — Part 3: Small plates*

ISO 295, *Plastics — Compression moulding of test specimens of thermosetting materials*

ISO 877, *Plastics — Methods of exposure to direct weathering, to weathering using glass-filtered daylight, and to intensified weathering by daylight using Fresnel mirrors*

ISO 2818, *Plastics — Preparation of test specimens by machining*

ISO 3167, *Plastics — Multipurpose test specimens*

ISO 4582, *Plastics — Determination of changes in colour and variations in properties after exposure to daylight under glass, natural weathering or laboratory light sources*

3 Terms and definitions

For the purposes of this document, the following terms and definitions apply.

3.1

control

(weathering) a material which is of similar composition and construction to the test material, and which is exposed at the same time for comparison with the test material

NOTE An example of the use of a control material would be when a formulation different from one currently being used is being evaluated. In that case, the control would be the plastic made with the original formulation.

3.2

file specimen

portion of the material to be tested which is stored under conditions in which it is stable, and is used for comparison between the exposed state and the original state

4 Principle

4.1 General

Replicate specimens of the appropriate size and shape are exposed floating on the surface of water, partially immersed in water or completely immersed in water. After the prescribed exposure interval, the specimens are removed from the water and tested/examined for changes in chemical, physical and/or appearance properties. In addition, the specimens may be tested for the type and severity of microbial growth or biofouling. Unless otherwise specified, test specimens are exposed in an unstrained state.

The exposure intervals at which the specimens are tested/examined are typically defined in terms of a given length of time. In some cases, however, the exposure interval may be expressed in terms of the total solar or solar ultraviolet radiation dosage. The climatic conditions are monitored during the exposure and reported with the other conditions of exposure.

4.2 Significance

The relative durability of materials in marine exposures can vary depending on the location of the exposure because of differences in ultraviolet radiation, ambient air temperature, water temperature, microorganisms, tidal action and contaminants in the water. Therefore, it cannot be assumed that results from one exposure in a particular location will be useful in determining the relative durability in another location. Exposures in several locations which represent a broad range of anticipated service conditions are recommended.

Exposure of the same material for the same length of time at different marine sites is not expected to result in identical degrees of degradation. This is also true for exposures at the same site, but during different seasons or in different years. Thus, the length of exposure is only a general indication of the extent of exposure and should always be considered in relation to the characteristics of the exposure site. Because of year-to-year climatic variations, results from a single exposure test cannot be used to predict the absolute rate at which a material degrades in marine exposures. Several years of repeat exposures are needed to get an "average" test result for a given location.

It is strongly recommended that at least one control material be part of any marine exposure evaluation. It is preferable to use two control materials, one with relatively good durability and one with relatively poor durability.

This International Standard covers plastic materials in film, sheet, laminate, monofilament, fibre, rope or netting form. This includes, but is not limited to, packaging films, fishing gear, monofilament fibres and ropes.

When filaments, fibres, ropes or netting are exposed, it may be appropriate to apply a stress or use weights during exposure to give a more realistic estimate of performance in actual service.

When marine exposures are used to evaluate enhanced-degradability plastic material, a comparable material not formulated for enhanced degradability might be used for comparison. The test results can then be used to obtain the rate of breakdown of the enhanced-degradability material relative to the other material. For most enhanced-degradability materials, particularly the enhanced-photodegradability materials, the time to embrittlement (reduction of ultimate extensibility to < 2 %, and therefore failure of the material) is only a few months of exposure. Therefore, the test results will depend heavily on the time of year the exposure is conducted.

For materials that are intended to have enhanced degradability, it is important to evaluate the degraded material after exposure to determine whether it is biodegradable.

The test results pertain solely to the geographical location where the test was carried out. Marine weathering exposure test sites should be chosen on the basis of the geographical region in which the plastic products are intended to be used. Selecting a location with high levels of solar radiation and a high ambient temperature is recommended when high rates of breakdown are desirable in comparative studies of several different materials.

With plastic materials expected to undergo enhanced biodegradation (of any of their components), it might be important to select a test site where the incidence of microorganisms and biofouling species is relatively high all year round. This allows the exposure to be completed in a relatively short time.

5 Requirements for apparatus

5.1 General requirements

Unless otherwise specified, the test site selected shall be free from oil contamination, with no visible sheen of petroleum oil on the water surface, and free from any chemical influx from land-based sources of pollution. The exposure raft shall be placed at a location that has a depth of at least 1 m at low tide. Care shall be taken to ensure that no shadows from nearby structures or other obstructions fall on the exposure raft or specimen-mounting racks.

ISO 15314:2004

NOTE Contaminated sites may be used to assess the effect of specific contaminants or environments.

Materials used to construct the exposure raft and racks shall be resistant to corrosion and not interact with or contaminate the specimens being exposed. Unless otherwise specified, use nonmetallic fasteners to attach specimens to the exposure raft and racks. Use of plastic pipe components for exposure raft and rack construction is recommended.

5.2 Requirements for method A, floating exposure

The floating rack shall be constructed of heavy-duty plastic pipe material that is not susceptible to microbial attack, and with a sufficient number of floats to ensure that the rack will not sink. Securely anchor the floating rack and ensure that specimens are always in contact with the surface of the water, regardless of tidal movements. Position the floating rack in a location where the water depth is at least 1 m at low tide. Structural members of the rack shall not provide backing or support for materials exposed on it. Figure 1 is a diagram showing a typical floating rack, used for method A, that is made from 15 mm to 25 mm diameter plastic pipe.

Dimensions in metres

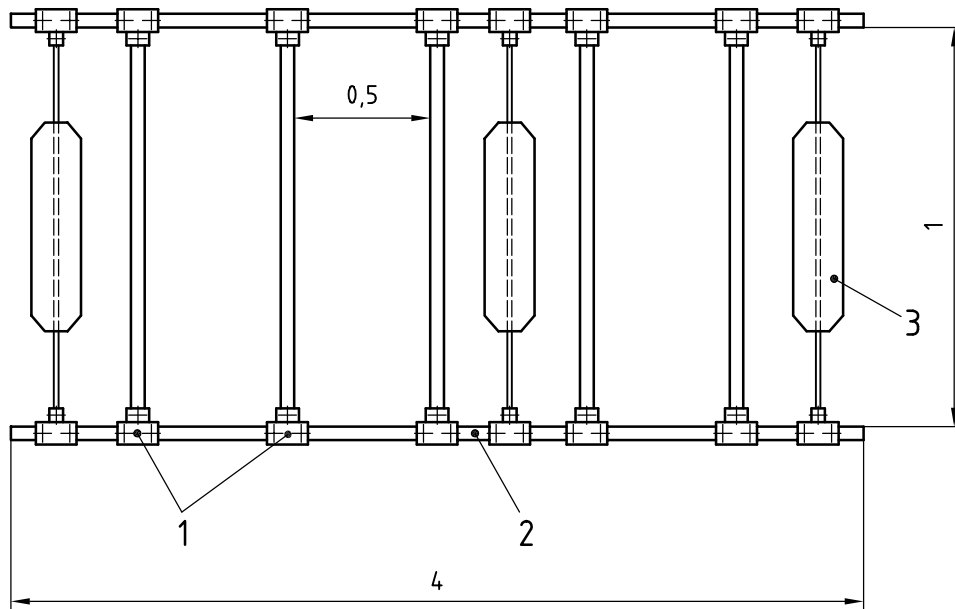

Key

- 1 T-fittings for plastic tubing [the use of non-corroding bolts (brass or stainless steel) in addition to glue is recommended for all joints]
- 2 15 mm to 25 mm diameter heavy-duty plastic tubing
- 3 foam float connected to frame using a plastic pipe that passes through the float (the use of three or more floats is recommended for a 4 m rack)

Figure 1 — Diagram of typical test rack used for floating exposures conducted in accordance with method A

5.3 Requirements for method B, partial-immersion exposure

Attach the test rack to a securely anchored floating raft to maintain the correct position in the water. Use a minimum amount of decking on the raft to ensure maximum exposure to sunlight of the surface of the test specimens. The exposure rack shall allow vertical installation of specimens and shall be positioned so that the prevailing tidal currents move parallel to the test specimen surface. Install racks to allow height adjustment to ensure that approximately one-half of each specimen is immersed and one-half is above the surface of the water. The maximum deviation from vertical of the lowest end of a test specimen shall be 20°. The minimum distance between adjacent rows of specimens shall be 30 cm, measured from the surface of the test specimens. The minimum distance between the edges of adjacent specimens shall be 15 mm. Figure 2 is a diagram of a typical rack used for method B. This rack would be attached to a floating raft at a distance of at least 0,5 m from the structural elements of the raft.

NOTE Placement of the exposure rack in accordance with methods B and C for flow of prevailing tidal current, and with the exposed face of the specimens oriented toward the equator, will ensure maximum exposure to sunlight.

Dimensions in metres

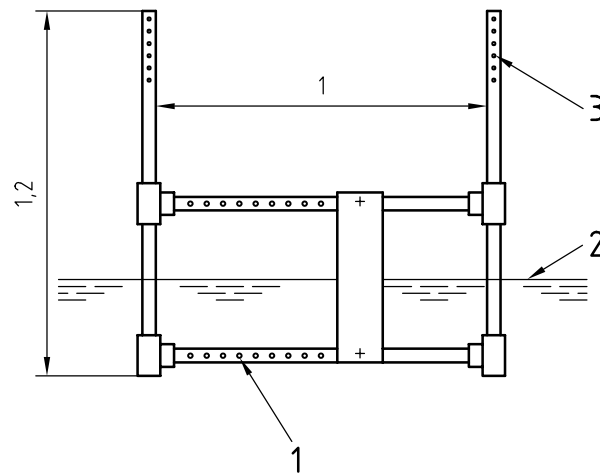
**Key**

- 1 15 mm to 30 mm diameter heavy-duty plastic tubing with series of regularly spaced holes for mounting specimens
- 2 surface of water
- 3 15 mm to 30 mm diameter heavy-duty plastic tubing with series of regularly spaced holes near top for attaching to floating raft and for adjusting specimens to appropriate immersion depth

Figure 2 — Diagram of typical rack used for partial-immersion exposures conducted in accordance with method B

5.4 Requirements for method C, shallow-immersion exposure

Attach the test rack to a securely anchored floating raft to maintain the correct position in the water. The exposure rack shall allow vertical installation of specimens and shall be positioned so that the prevailing tidal currents move parallel to the test specimen surface. If the exposure rack is constructed of metal, test specimens shall be electrically isolated from the rack. The exposure rack shall allow immersion of specimens to a depth of a least 0,3 m, but no more than 3 m. The minimum distance between the front face of a specimen to the back of the nearest specimen shall be 60 mm. The minimum distance between the edges of adjacent specimens shall be 15 mm. Figure 3 is a diagram of a typical rack used for method C. This example provides for two rows of test specimens.

6 Test specimens

6.1 Form and preparation

The methods used for preparation of test specimens can have a significant impact on their apparent durability. Therefore, the method used for specimen preparation shall be agreed upon by the interested parties and should preferably be closely related to the method normally used to process the material in typical applications. A complete description of the method used for preparation of test specimens shall be included with the test report.

The dimensions of the test specimens are normally those specified in the appropriate test method for the property or properties to be measured after exposure. When the behaviour of a specific type of article is to be determined, the article itself shall be exposed whenever possible.

Label all specimens with an identifying code. It is recommended that this label be engraved or indented into the specimen. Writing on the specimen can be obliterated with exposure and therefore is not useful for specimen identification after exposure. If specimens are too small or too fragile for engraving or indenting, mark a separate tag and attach to the specimen in such a manner that it does not interact with the specimen or shield it from exposure.