**Solid mineral fuels — Determination of
total fluorine in coal, coke and fly ash**

*Combustibles minéraux solides — Détermination de la teneur totale en
fluor dans le charbon, le coke et les cendres*

iTeh STANDARD PREVIEW
(standards.iteh.ai)

[SIST ISO 11724:2005](https://standards.iteh.ai/catalog/standards/sist/fc0c0166-fca4-484b-b5c6-93d6d4f1b4b2/sist-iso-11724-2005)

[https://standards.iteh.ai/catalog/standards/sist/fc0c0166-fca4-484b-b5c6-
93d6d4f1b4b2/sist-iso-11724-2005](https://standards.iteh.ai/catalog/standards/sist/fc0c0166-fca4-484b-b5c6-93d6d4f1b4b2/sist-iso-11724-2005)



PDF disclaimer

This PDF file may contain embedded typefaces. In accordance with Adobe's licensing policy, this file may be printed or viewed but shall not be edited unless the typefaces which are embedded are licensed to and installed on the computer performing the editing. In downloading this file, parties accept therein the responsibility of not infringing Adobe's licensing policy. The ISO Central Secretariat accepts no liability in this area.

Adobe is a trademark of Adobe Systems Incorporated.

Details of the software products used to create this PDF file can be found in the General Info relative to the file; the PDF-creation parameters were optimized for printing. Every care has been taken to ensure that the file is suitable for use by ISO member bodies. In the unlikely event that a problem relating to it is found, please inform the Central Secretariat at the address given below.

iTeh STANDARD PREVIEW
(standards.iteh.ai)

[SIST ISO 11724:2005](https://standards.iteh.ai/catalog/standards/sist/iso-11724-2005)

<https://standards.iteh.ai/catalog/standards/sist/fe0c0166-fca4-484b-b5c6-93d6d4f1b4b2/sist-iso-11724-2005>

© ISO 2004

All rights reserved. Unless otherwise specified, no part of this publication may be reproduced or utilized in any form or by any means, electronic or mechanical, including photocopying and microfilm, without permission in writing from either ISO at the address below or ISO's member body in the country of the requester.

ISO copyright office
Case postale 56 • CH-1211 Geneva 20
Tel. + 41 22 749 01 11
Fax + 41 22 749 09 47
E-mail copyright@iso.org
Web www.iso.org

Published in Switzerland

Contents

Page

Foreword.....	iv
1 Scope.....	1
2 Normative references	1
3 Principle	1
4 Reagents	1
5 Apparatus.....	2
6 Sample.....	4
6.1 Coal and coke	4
6.2 Fly ash	5
7 Procedure.....	5
7.1 Number of determinations	5
7.2 Preparation of test sample	5
7.3 Blank tests	5
7.4 Pyrohydrolysis procedure.....	5
7.5 Solution measurement	6
8 Calculations	7
8.1 General	7
8.2 Direct-comparison ISE method	8
8.3 Analyte-addition ISE method	8
8.4 IC method.....	9
9 Expression of result.....	9
10 Precision	9
10.1 Repeatability limit	9
10.2 Reproducibility critical difference	10
11 Test report.....	10
Bibliography	11

Foreword

ISO (the International Organization for Standardization) is a worldwide federation of national standards bodies (ISO member bodies). The work of preparing International Standards is normally carried out through ISO technical committees. Each member body interested in a subject for which a technical committee has been established has the right to be represented on that committee. International organizations, governmental and non-governmental, in liaison with ISO, also take part in the work. ISO collaborates closely with the International Electrotechnical Commission (IEC) on all matters of electrotechnical standardization.

International Standards are drafted in accordance with the rules given in the ISO/IEC Directives, Part 2.

The main task of technical committees is to prepare International Standards. Draft International Standards adopted by the technical committees are circulated to the member bodies for voting. Publication as an International Standard requires approval by at least 75 % of the member bodies casting a vote.

Attention is drawn to the possibility that some of the elements of this document may be the subject of patent rights. ISO shall not be held responsible for identifying any or all such patent rights.

ISO 11724 was prepared by Technical Committee ISO/TC 27, *Solid mineral fuels*, Subcommittee SC 5, *Methods of analysis*.

iTeh STANDARD PREVIEW (standards.iteh.ai)

[SIST ISO 11724:2005](https://standards.iteh.ai/catalog/standards/sist/fc0c0166-fca4-484b-b5c6-93d6d4f1b4b2/sist-iso-11724-2005)

<https://standards.iteh.ai/catalog/standards/sist/fc0c0166-fca4-484b-b5c6-93d6d4f1b4b2/sist-iso-11724-2005>

Solid mineral fuels — Determination of total fluorine in coal, coke and fly ash

1 Scope

This International Standard specifies a method for the determination of total fluorine in coal, coke and fly ash.

From measurement of the total fluorine alone, it is not possible to estimate the amount of fluorine released to the environment by utilization of the coal and subsequent disposal of the ash residue.

2 Normative references

The following referenced documents are indispensable for the application of this document. For dated references, only the edition cited applies. For undated references, the latest edition of the referenced document (including any amendments) applies.

ISO 589:2003, *Hard coal — Determination of total moisture*

ISO 687:1974, *Coke — Determination of moisture in the analysis sample*

ISO 5068:1983, *Brown coals and lignites — Determination of moisture content — Indirect gravimetric method*

ISO 5069-2:1983, *Brown coals and lignites — Principles of sampling — Part 2: Sample preparation for determination of moisture content and for general analysis*

ISO 11722:1999, *Solid mineral fuels — Hard coal — Determination of moisture in the general analysis test sample by drying in nitrogen*

ISO 13909-4:2001, *Hard coal and coke — Mechanical sampling — Part 4: Coal — Preparation of test samples*

ISO 13909-6:2001, *Hard coal and coke — Mechanical sampling — Part 6: Coke — Preparation of test samples*

3 Principle

Mixing of the sample of coal, coke or fly ash with silica, and pyrohydrolysis in a tube furnace at approximately 1 200 °C in an atmosphere of oxygen and water vapour. Absorption of the volatilized fluorine compounds in a suitable solution and processing for determination by ion-selective electrode (ISE) or ion chromatographic (IC) techniques.

4 Reagents

CAUTION — Care must be exercised when handling reagents, some of which are toxic and corrosive.

During the analysis, use only reagents of recognized analytical grade and only distilled water, or water of equivalent purity.

4.1 Silica of top size 75 µm, ignited at 1 000 °C for 1 h.

CAUTION — Fine silica is dangerous to health if inhaled.

4.2 Solutions for ISE measurement

4.2.1 Standard fluorine solution (1 g contains 200 µg of F).

a) For direct-comparison method

Dissolve 0,221 0 ± 0,000 2 g of dry (110 °C for 1 h) sodium fluoride in approximately 400 ml of water contained in a tared plastic bottle, dilute to 500 g ± 0,5 g net with water, and mix.

b) For analyte-addition method

Dissolve 0,221 0 ± 0,000 2 g of dry (110 °C for 1 h) sodium fluoride in a tared plastic bottle containing 150 ml of water and 100 g of buffer (4.2.3). Dilute to 500 g ± 0,5 g net with water, and mix.

4.2.2 Absorption solution (0,025 mol/l NaOH).

Dissolve 2,0 g of sodium hydroxide in about 500 ml of water. Transfer to a tared 2,5 litre plastic bottle, dilute to 2 000 g net with water, and mix.

4.2.3 Buffer (pH 6,5).

Dissolve 10,0 g of potassium nitrate, 5 g of 1,2-cyclohexylenedinitrilotetraacetic acid (CDTA) and 115 g of ammonium acetate in 350 ml of water. Adjust the pH to 6,5 with glacial acetic acid. Dilute to 500 g net with water, and mix.

4.2.4 Solution for conditioning fluoride ISE. [SIST ISO 11724:2005](https://standards.iteh.ai/catalog/standards/sist/iso/11724/2004/iso-11724-2004)

Weigh 20 g of water, 20 g of absorption solution (4.2.2) and 10 g of buffer (4.2.3) into a polystyrene vial (5.2). Add approximately 200 mg of standard fluorine solution [of 4.2.1 a) or 4.2.1 b)], and mix.

4.3 Solutions for IC measurement

4.3.1 Standard fluorine solution (1 g contains 200 µg of F).

Dissolve 0,221 0 ± 0,000 2 g of dry (110 °C for 1 h) sodium fluoride in approximately 400 ml of water contained in a tared plastic bottle, dilute to 500 g ± 0,5 g net with water, and mix.

4.3.2 Absorption solution for IC measurement.

Dissolve 0,300 g of sodium hydrogen carbonate and 1,120 g of sodium carbonate in approximately 500 ml of water and dilute to 2 litres.

4.4 Oxygen, compressed.

5 Apparatus

5.1 Vials, made of glass or polystyrene, of capacity 10 ml to 30 ml with tightly fitting snap-on plastic caps.

5.2 Polypropylene bottles or polystyrene vials, tared, of capacity 125 ml, wide necked with linerless leakproof screw caps.

5.3 Balances: a balance capable of weighing to the nearest 0,000 1 g; a balance capable of weighing approximately 200 g to the nearest 0,001 g; a balance capable of weighing 600 g to the nearest 0,01 g; and a balance capable of weighing 3 000 g to the nearest 0,1 g.

5.4 Polyethylene dispensing bottles, for the standard fluorine solution (4.2.1), absorption solution (4.2.2) and buffer (4.2.3).

5.5 Micropipette, of variable volume, ranging to at least 1 ml.

This is a satisfactory alternative to the 250 ml polyethylene dispensing bottle (5.4) for delivery of small weighed volumes of standard fluorine solution (4.2.1).

5.6 Apparatus for tube-furnace pyrohydrolysis (see Figure 1).

5.6.1 Steam generator, consisting of the following:

- a) round-bottom flask, 2 litre capacity;
- b) heating mantle, 2 litre capacity;
- c) Y-piece, glass, 10 mm diameter;
- d) oxygen distribution tube, porosity 0;
- e) stopcocks, one three-way and one two-way.

5.6.2 Silica-tube furnace and accessories

The apparatus is similar to that used in ISO 351.

a) **Silica tube**, made of translucent pure silica (25 mm outer diameter, 20 mm inner diameter), of length (typically 700 mm) appropriate to the particular furnace used (generally of an approximate length of 400 mm). Preferably, the gas outlet end should be narrowed to a tubule of approximately 7 mm diameter.

NOTE Combustion tubes of alternative refractory compositions do not have adequate thermal stress characteristics for operation with this method.

b) **Silicone stoppers**, 20 mm diameter, positioned at inlet end (and outlet, if applicable) of the silica tube described in a).

c) **Combustion boats**, made of high-alumina unglazed porcelain (approximately 97 mm × 16 mm × 12 mm), preignited at 1 000 °C for 1 h.

d) **Silica pusher and T-tube**, comprising a silica push rod (5 mm diameter and 500 mm long) fused at one end to provide a flat disc surface of 10 mm to 12 mm diameter, and having a piece of magnetic steel affixed to the other end by epoxy resin. The T-tube (500 mm long) is composed of borosilicate glass and protrudes 10 mm into the silica tube a) through a stopper b). The stem of the T-tube is connected to the steam generator by way of the three-way stopcock [5.6.1 e)]. A magnet is used to move the pusher inside the T-tube.

e) **Combustion furnace**, capable of reaching a temperature of at least 1 200 °C.

5.6.3 Absorption vessel: Dreschel gas washing bottle or equivalent, of capacity 125 ml, with gas-distribution tube fitted with a sintered glass disc of 15 µm to 40 µm pore size [5.6.1 d)] bent at 90°, approximately 60 mm from the top.

5.6.4 Water jacket, suitable for containing the absorption vessel.

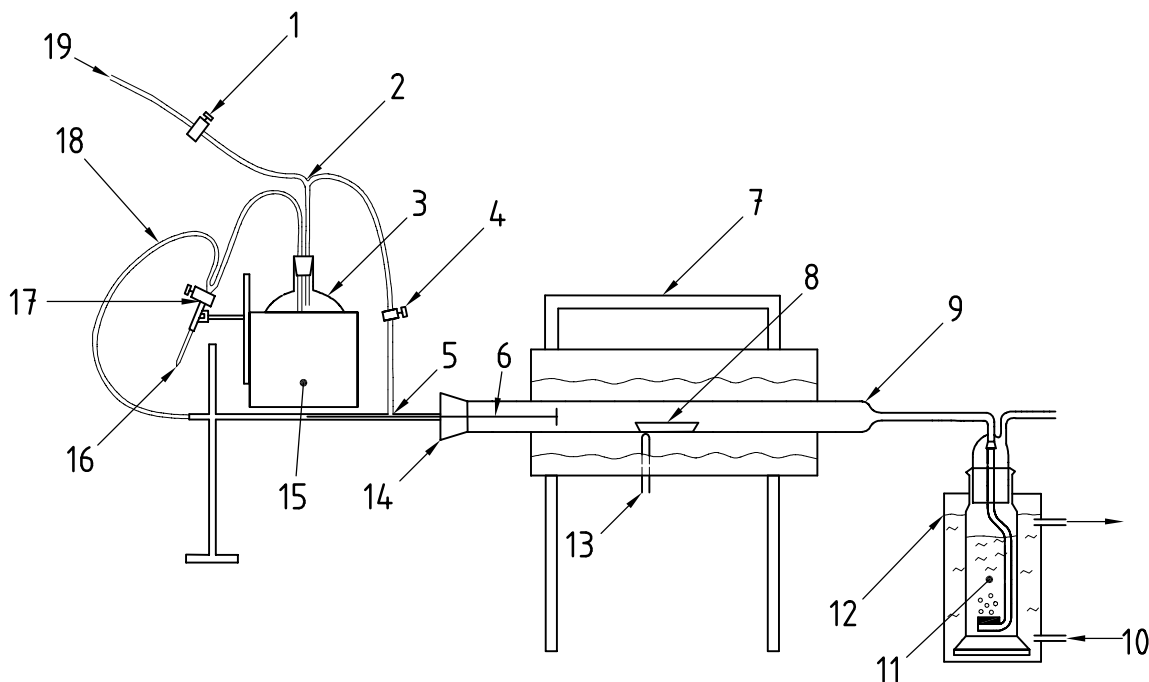

Key		
1 stopcock	8 combustion boat	15 heating mantle
2 Y-piece	9 silica tube	16 oxygen in
3 round-bottom flask	10 cooling water	17 three-way stopcock
4 stopcock	11 absorption vessel	18 steam distribution tube
5 T-piece	12 water jacket	19 to sink
6 silica pusher	13 thermocouple	
7 furnace	14 silicone stopper	

Figure 1 — Schematic diagram of pyrohydrolysis apparatus

5.7 ISE measurement apparatus

5.7.1 **Magnetic stirrer**, complete with polytetrafluoroethylene stirring bars.

5.7.2 **Electrodes**: a solid state fluoride ion selective electrode and a reference electrode.

The sensing element of the fluoride electrode should be polished on each day of use to prolong optimal performance. This may be achieved, for example, by using 0,25 mm diamond dust or alumina sprayed on a polishing cloth, and polishing the electrode for 30 s to 60 s. The electrode, having been stored dry, is conditioned for at least 30 min prior to use, by insertion in a conditioning solution (4.2.4).

5.7.3 **Millivoltmeter**, having a resolution of 0,1 mV.

5.8 **IC measurement apparatus**, equipped with a chromatography pump, anion separation columns, conductivity detector and integrator.

6 Sample

6.1 Coal and coke

The test sample is the general analysis sample prepared in accordance with ISO 5069-2, ISO 13909-4 or ISO 13909-6, as appropriate.

6.2 Fly ash

Fly ash normally has a top particle size of less than 75 μm and therefore may not require any reduction prior to analysis. However, special care shall be taken in the collection and preparation of representative samples and in avoiding contamination.

7 Procedure

7.1 Number of determinations

The analysis should be carried out in duplicate on separate test portions of the coal, coke or fly ash.

7.2 Preparation of test sample

The test sample mass taken for the analysis is dependent upon the mass fraction of fluorine present. The following procedure assumes mass fractions of fluorine up to a maximum of 2 000 $\mu\text{g/g}$. If higher fluorine mass fractions are anticipated or found to be present, proportionately lower sample masses shall be taken to ensure maximal recovery of fluorine from the sample matrix.

Accurately weigh 250 mg, to the nearest 0,1 mg, of the coal, coke or fly ash (this is the sample mass, m_s) and mix well with 250 mg \pm 5 mg of silica (4.1) in a vial (5.1). If calculation to bases other than as-received is required, concurrently weigh another sample for determination of the moisture in the coal, coke or fly ash by one of the methods specified in ISO 589, ISO 11722, ISO 5068 or ISO 687, as appropriate.

7.3 Blank tests

Blank tests should be carried out in duplicate with each batch of test samples.

7.4 Pyrohydrolysis procedure

7.4.1 Apparatus conditioning

To the round-bottom flask [5.6.1 a)], add a few boiling chips and 1 600 ml of water. Allow the steam generator to achieve gentle boiling. Connect an absorption vessel (5.6.3) containing about 50 ml of water. With the furnace set at an operational temperature of 1 200 $^{\circ}\text{C}$, pass oxygen through the steam generator into the furnace at approximately 750 ml/min for 15 min.

To minimize condensation of steam, the silica tube should be positioned inside the furnace, so that less than 100 mm protrudes at the outlet end. The oxygen flow and the temperature of steam generation should be adjusted so that approximately 40 g of condensate is collected during 18 min of pyrohydrolysis.

To avoid excessive warping of the silica tube, the temperature should not rise above 1 225 $^{\circ}\text{C}$.

7.4.2 Pyrohydrolysis

Add 50 ml \pm 1 ml of appropriate absorption solution (4.2.2 or 4.3.2) to the absorption vessel (5.6.3). Secure to the outlet of the combustion tube assembly (silicone rubber tubing and glass-silica contact if a tubular outlet combustion tube [5.6.2 a)] is used. Position the water jacket around the absorption vessel and ensure an adequate flow of cooling water.

Transfer the sample/silica mixture from the vial (5.1) to a combustion boat.

Allow oxygen to flow, by-passing the steam generator, at 750 ml/min into the furnace. Place the test sample boat into the inlet end of the combustion tube so that it is approximately 200 mm from the centre of the hottest zone. Reconnect the silica pusher and T-tube and, after 1 min, redirect the oxygen flow through the steam generator into the combustion tube. At five subsequent intervals of approximately 30 s, push the test sample