



Designation: D 2540 – 93 (Reapproved 2001)

Standard Test Method for Drop-Weight Sensitivity of Liquid Monopropellants¹

This standard is issued under the fixed designation D 2540; the number immediately following the designation indicates the year of original adoption or, in the case of revision, the year of last revision. A number in parentheses indicates the year of last reapproval. A superscript epsilon (ϵ) indicates an editorial change since the last revision or reapproval.

1. Scope

1.1 This test method² covers the determination of the sensitivity of liquid monopropellants to the impact of a drop weight.

1.2 This standard should be used to measure and describe the properties of materials, products, or assemblies in response to heat and flame under controlled laboratory conditions and should not be used to describe or appraise the fire hazard or fire risk of materials, products, or assemblies under actual fire conditions. However, results of this test may be used as elements of a fire risk assessment which takes into account all of the factors which are pertinent to an assessment of the fire hazard of a particular end use.

1.3 This standard does not purport to address all of the safety concerns, if any, associated with its use. It is the responsibility of the user of this standard to establish appropriate safety and health practices and determine the applicability of regulatory limitations prior to use.

1.4 The values stated in SI units are to be regarded as the standard. The values given in parentheses are for information only.

2. Summary of Test Method

2.1 A small sample of the liquid (0.03 mL) to be tested is enclosed in a cavity (0.06 mL) formed by a steel cup, an elastic ring, and a steel diaphragm (see Fig. 1). A piston rests on the diaphragm and carries a vent hole which is blocked by the steel diaphragm. A weight is dropped onto the piston. A positive result is indicated by puncture of the steel diaphragm accompanied by a loud noise or severe deformation of the diaphragm and evidence that the sample was completely consumed. The sensitivity value for a given sample shall be expressed as the height from which the specified weight is dropped for the probability of explosion to be 50 %.

¹ This test method is under the jurisdiction of ASTM Committee F07 on Aerospace and Aircraft and is the direct responsibility of Subcommittee F 07.90 on Executive.

Current edition approved March 15, 1993. Published May 1993. Originally published as D 2540 – 66 T. Last previous edition D 2540 – 70 (1982)¹.

² This method is identical in substance with the JANNAF method, "Drop Weight Test," Test Number 4, Liquid Propellant Test Methods, May 1964, published by the Chemical Propulsion Information Agency, Johns Hopkins University, Applied Physics Laboratory, Johns Hopkins Rd., Laurel, Md. 20810.

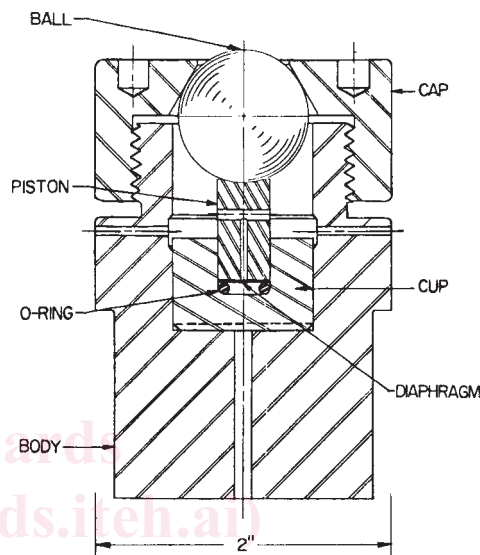

FIG. 1 Sample Cup Assembly

3. Significance and Use

3.1 In drop-weight testing of liquids, explosions are initiated in a complex compression process involving the degree and rate of pressurization, the thermodynamic gas properties, heat transfer, hydrodynamic properties, etc. At this time, the fundamental significance of the test cannot be exactly defined. The test is considered useful, however, as a rapid and simple means to rate sensitive liquids as to their relative explosive sensitivity. Since it requires only a few grams of sample, it can be an important laboratory tool to determine the handling safety of new materials before substantial quantities are prepared.

3.2 Tests in which the sample volume is varied (at constant cavity volume of 0.06 mL) show that the degree of filling affects the result. Note that the relationship between sensitivity rating and sample volume is not a characteristic of the test apparatus but is a function specific to each propellant. At 50 % filling (0.03 mL of sample), the dependency of sensitivity on sample volume is moderate so that the error in sample volume measurement has a negligible influence. Tests show that the delivered sample volume is reproducible to $\pm 0.5\%$ when measured by a fixed-stroke syringe, and 0.03 mL shall be the standard sample volume.

3.3 If the objective justifies the greater effort, the sample volume is varied leading to a plot such as shown in Fig. 2 which represents the relationship between sensitivity rating and sample volume for the specific propellant *n*-propyl nitrate.

4. Apparatus

4.1 *Sample Cup Assembly*—The sample cup assembly is shown in Fig. 1, and an exploded view in Fig. 3. The assembly shall consist of the following parts:

Part No.	Name
1	body
2	cup
3	O-ring (expendable)
4	diaphragm (expendable)
5	piston
6	ball
7	cap

Since the sample cup assembly is the critical part of the drop-weight tester, detailed dimensions of its components are given in Fig. 4.

4.2 *Weight*—The weight shall be one integral assembly, weighing $2\text{ kg} \pm 1\text{ g}$ (Fig. 5). The weight shall be held suspended by an electromagnet. The electromagnet shall itself be held in the first version of the drop-weight tester by a stud at the top which fits in the recess formerly designed to hold and release the weight. The release shall be tied down to hold the magnet firmly in place. The present magnet plus weight shall be of such a length that the scale on the right hand post will read the correct drop height.

4.2.1 In using this weight, constant vigilance shall be maintained to see that the weight tip does not become excessively worn or damaged. If excessive wear is indicated the apparatus should be rechecked on a standard sample. Damaged weights should be discarded.

4.3 *Drop-Weight Assembly* (Fig. 6), consisting of a base plate with four leveling screws; column; two guide rods (one graduated); body retainer; release mechanism, adjustable to retain magnet; and top plate.

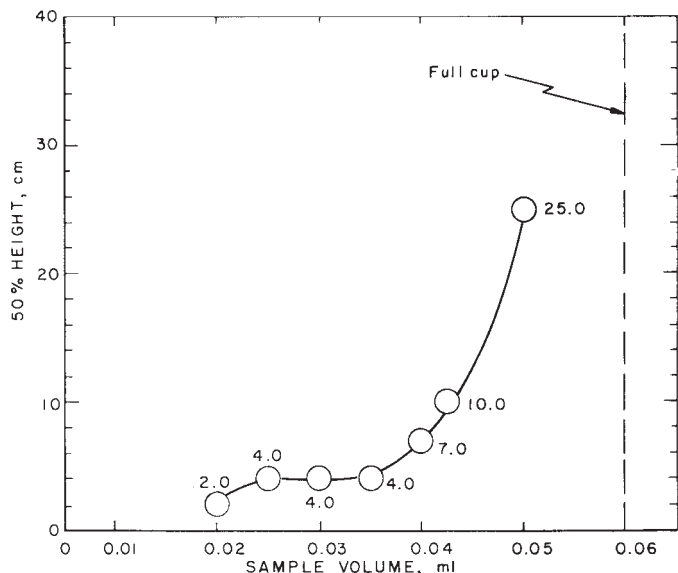

FIG. 2 Impact Sensitivity, H_{50} , of NPN versus Sample Volume at 70°F (21.1°C) Using a 2-kg Weight

4.4 *Tools*, consisting of a torque wrench, 0 to 1.7-N·m (0 to 15-lb·in.) torque wrench adaptor to fit cap (part 7 of Fig. 4); hypodermic syringe of fixed stroke; O-ring seating tool; brass pick; and spanner wrench.

4.5 *Expandables*, such as O-rings: either AN 6227B-5 or $6.07 \pm 0.13\text{-mm}$ ($0.239 \pm 0.005\text{-in.}$) inside diameter and 1.78-mm (0.070-in.) cross section width, made from MIL-P-5516 elastomer, or both; and diaphragms of Type 302 stainless steel $0.41 \pm 0.013\text{ mm}$ ($0.016 \pm 0.0005\text{ in.}$) thick, 9.22 mm (0.363 in.) in diameter.

5. Safety Precautions

5.1 A positive safety latch shall be provided to prevent injury resulting from the premature fall of the weight. It is realized that this test might be employed for the evaluation of ultra-high-energy materials. This fact, combined with the possibility of faulty fabrication of components, could result in the production of shrapnel. It is therefore recommended that the apparatus be shielded (Fig. 7).

5.2 If the test apparatus is to be employed for the evaluation of toxic materials, or if toxic products may be formed from the decomposition of the sample, necessary steps shall be taken to prevent the buildup of dangerous concentrations of these materials.

6. Preparation of Apparatus

6.1 Experience has shown that an appreciable difference in the behavior of the apparatus can result from the manner in which it is mounted. Therefore, the following conditions shall be met:

6.1.1 The machine shall be mounted on and firmly attached to a solid concrete foundation, preferably anchored to the foundation of the building.

6.1.2 The machine shall be perfectly plumb with guides lubricated to minimize friction during the fall of the weight.

6.2 The drop-weight sensitivity of sensitive liquids is, of course, dependent on the purity of the sample. The magnitude of this dependency will vary with the material. If attempts are being made to reproduce data obtained by other investigations, care shall be taken to obtain samples having identical analyses. Particular care shall be taken to keep the samples dry, as moisture may have an adverse effect.

7. Procedure

7.1 Results of this test have been found to be temperature-dependent. It is therefore very important to provide means to thermostat the sample cups, pistons, body of the assembly, and the liquid to be tested unless the whole equipment is kept in a constant-temperature room. Make all tests at $21.1 \pm 1.1^\circ\text{C}$ ($70 \pm 2^\circ\text{F}$).

7.1.1 Clean and dry all components of the body assembly. It is good practice to wash the metal parts in acetone and blow out both the exhaust hole and the cup with clean dry air. Wipe the cup clean with a tissue or soft cloth. After positive tests, check the exhaust hole and ports of the piston to be sure they are clear of the blown out section of the diaphragm. Note the condition of the pistons and cups. Replace cracked, pitted, or worn components.

ASTM D 2540 – 93 (2001)

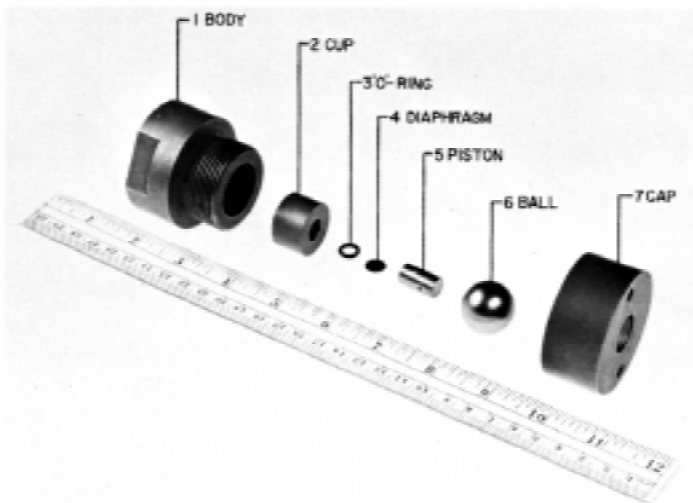

FIG. 3 Sample Cup Assembly, Exploded View

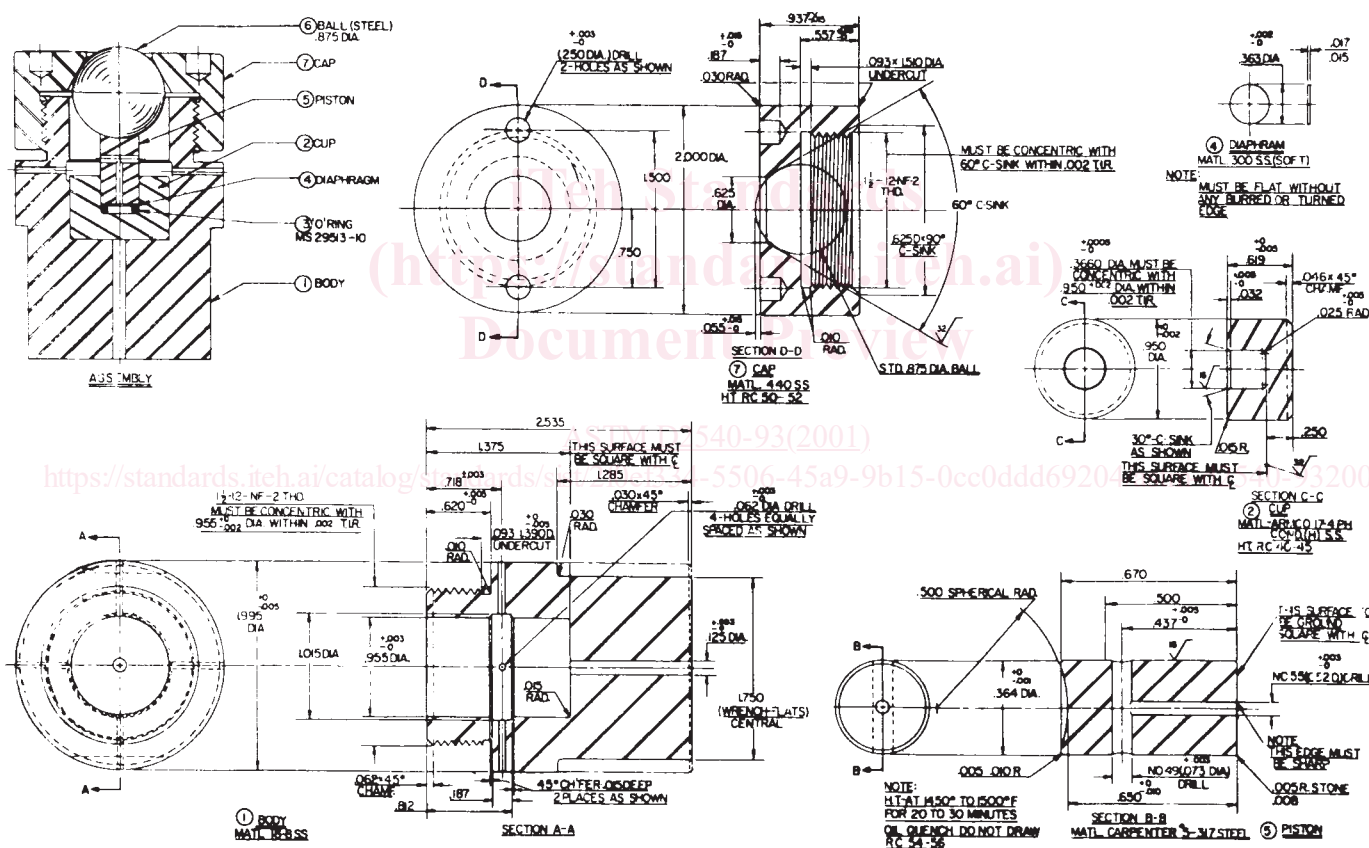

FIG. 4 Sample Cup Assembly, Detailed View

NOTE 1—For temperature uniformity and speed of operation, it is recommended that a separate cup and piston be used for each test in a series. This also ensures that possible cup damage will not affect the results of subsequent tests in the series.

7.1.2 Set the height by loosening the locking handle that binds the release mechanism to the support column, and sliding the mechanism until the height indicator is properly aligned with the graduated guide rod. Tighten the locking handle and set the safety latch.

7.1.3 Place an AN 6227B-5 O-ring in the bottom of the cup, and with the brass O-ring seating tool force it down until it is firmly seated.

7.1.4 Fill the syringe with liquid and sweep out all entrapped air; wipe the point of the needle free of liquid; lower the point to the bottom of the cavity; carefully inject 0.03 mL into the cavity.