**Pneumatic fluid power — Assessment of
component reliability by testing —**

**Part 4:
Pressure regulators**

*Transmissions pneumatiques — Évaluation par essais de la fiabilité des
composants*

iTeh STANDARD PREVIEW
Partie 4: Régulateurs de pression
(standards.iteh.ai)

ISO 19973-4:2007

[https://standards.iteh.ai/catalog/standards/sist/6f8a15bb-8439-456f-8f23-
d49910b6e7a4/iso-19973-4-2007](https://standards.iteh.ai/catalog/standards/sist/6f8a15bb-8439-456f-8f23-d49910b6e7a4/iso-19973-4-2007)



PDF disclaimer

This PDF file may contain embedded typefaces. In accordance with Adobe's licensing policy, this file may be printed or viewed but shall not be edited unless the typefaces which are embedded are licensed to and installed on the computer performing the editing. In downloading this file, parties accept therein the responsibility of not infringing Adobe's licensing policy. The ISO Central Secretariat accepts no liability in this area.

Adobe is a trademark of Adobe Systems Incorporated.

Details of the software products used to create this PDF file can be found in the General Info relative to the file; the PDF-creation parameters were optimized for printing. Every care has been taken to ensure that the file is suitable for use by ISO member bodies. In the unlikely event that a problem relating to it is found, please inform the Central Secretariat at the address given below.

iTeh STANDARD PREVIEW
(standards.iteh.ai)

ISO 19973-4:2007

<https://standards.iteh.ai/catalog/standards/sist/6f8a15bb-8439-456f-8f23-d49910b6e7a4/iso-19973-4-2007>



COPYRIGHT PROTECTED DOCUMENT

© ISO 2007

All rights reserved. Unless otherwise specified, no part of this publication may be reproduced or utilized in any form or by any means, electronic or mechanical, including photocopying and microfilm, without permission in writing from either ISO at the address below or ISO's member body in the country of the requester.

ISO copyright office
Case postale 56 • CH-1211 Geneva 20
Tel. + 41 22 749 01 11
Fax + 41 22 749 09 47
E-mail copyright@iso.org
Web www.iso.org

Published in Switzerland

Contents

Page

| | |
|--|----|
| Foreword..... | iv |
| Introduction | v |
| 1 Scope | 1 |
| 2 Normative references | 1 |
| 3 Terms and definitions..... | 2 |
| 4 Symbols and units | 2 |
| 5 Test equipment | 2 |
| 5.1 Basic test equipment..... | 2 |
| 5.2 Directional control valve | 3 |
| 5.3 Connecting piping | 3 |
| 6 Test conditions | 3 |
| 6.1 General test conditions | 3 |
| 6.2 Inlet and outlet pressures | 3 |
| 6.3 Pressure-cycle trace for the endurance test..... | 3 |
| 7 Test procedure | 3 |
| 7.1 Selection of test units..... | 3 |
| 7.2 Timing of checks and measurements..... | 3 |
| 7.3 Type and scope of checks and measurements | 4 |
| 7.4 Endurance test | 4 |
| 8 Threshold levels..... | 5 |
| 8.1 General..... | 5 |
| 8.2 Functional failure | 5 |
| 8.3 Failure due to leakage | 5 |
| 8.4 Failure due to pressure characteristics..... | 6 |
| 9 Data analysis | 6 |
| 10 Test report | 6 |
| 11 Identification statement..... | 6 |
| Annex A (informative) Flow chart illustrating the test procedure specified in this part of ISO 19973 | 7 |
| Bibliography | 8 |

Foreword

ISO (the International Organization for Standardization) is a worldwide federation of national standards bodies (ISO member bodies). The work of preparing International Standards is normally carried out through ISO technical committees. Each member body interested in a subject for which a technical committee has been established has the right to be represented on that committee. International organizations, governmental and non-governmental, in liaison with ISO, also take part in the work. ISO collaborates closely with the International Electrotechnical Commission (IEC) on all matters of electrotechnical standardization.

International Standards are drafted in accordance with the rules given in the ISO/IEC Directives, Part 2.

The main task of technical committees is to prepare International Standards. Draft International Standards adopted by the technical committees are circulated to the member bodies for voting. Publication as an International Standard requires approval by at least 75 % of the member bodies casting a vote.

Attention is drawn to the possibility that some of the elements of this document may be the subject of patent rights. ISO shall not be held responsible for identifying any or all such patent rights.

ISO 19973-4 was prepared by Technical Committee ISO/TC 131, *Fluid power systems*.

ISO 19973 consists of the following parts, under the general title *Pneumatic fluid power — Assessment of component reliability by testing*:

— *Part 1: General procedures*

— *Part 2: Directional control valves*

— *Part 3: Cylinders with piston rod*

— *Part 4: Pressure regulators*

ITEH STANDARD PREVIEW

(standards.iteh.ai)

[ISO 19973-4:2007](https://standards.iteh.ai/catalog/standards/sist/6f8a15bb-8439-456f-8f23-d49910b6e7a4/iso-19973-4-2007)

<https://standards.iteh.ai/catalog/standards/sist/6f8a15bb-8439-456f-8f23-d49910b6e7a4/iso-19973-4-2007>

Introduction

In pneumatic fluid power systems, power is transmitted and controlled through a gas under pressure within a circuit. Pneumatic fluid power systems are composed of components and are an integral part of various types of machines and equipment. Efficient and economical production requires highly reliable machines and equipment. Within the ISO 19973 series, this part 4 is intended to provide requirements and test conditions that permit the assessment of the inherent reliability of pneumatic pressure regulators.

Machine producers need to know the reliability of the components that make up their machine's pneumatic fluid power system. Knowing the reliability characteristic of the component, the producers can model the system and make decisions on service intervals, the spare parts inventory and areas for future improvements.

There are three primary levels in the determination of component reliability:

- a) preliminary design analysis — finite element analysis (FEA), failure mode and effect analysis (FMEA);
- b) laboratory testing and reliability modelling — physics of failure, reliability prediction, pre-production evaluation;
- c) collection of field data — maintenance reports, warranty analysis.

Each level has its specific application during the life of a component. A preliminary design analysis is useful to identify possible failure modes and eliminate them or reduce their effect on reliability. When prototypes are available, in-house laboratory reliability tests are run and initial reliability can be determined. Reliability testing is often continued into the initial production run and throughout the production lifetime as a continuing evaluation of the component. Collection of field data is possible when products are operating and data on their failures are available.

iTeh STANDARD PREVIEW
(standards.iteh.ai)

ISO 19973-4:2007

<https://standards.iteh.ai/catalog/standards/sist/6f8a15bb-8439-456f-8f23-d49910b6e7a4/iso-19973-4-2007>

Pneumatic fluid power — Assessment of component reliability by testing —

Part 4: Pressure regulators

1 Scope

This part of ISO 19973 provides test procedures for assessing the reliability of pneumatic pressure regulators by testing and the methods of reporting the results of testing. General test conditions and the calculation method are provided in ISO 19973-1. The methods specified in ISO 19973-1 apply to the first failure without repairs, but exclude outliers.

The lifetime of pneumatic pressure regulators is usually given as a number of cycles. Therefore, whenever the term “time” is used in this part of ISO 19973, this variable shall be understood as cycles.

This part of ISO 19973 applies to manually adjustable and remote-piloted pressure regulators, both relieving and non-relieving. This part of ISO 19973 does not apply to pressure regulators that have a permanent bleed.

This part of ISO 19973 also specifies test equipment and failure criteria (threshold levels) for tests to assess the reliability of pneumatic pressure regulators.

The life determined by the method in this part of ISO 19973 and in ISO 19973-1 is more conservative than the life experienced in actual field service.

2 Normative references

The following referenced documents are indispensable for the application of this document. For dated references, only the edition cited applies. For undated references, the latest edition of the referenced document (including any amendments) applies.

ISO 1000, *SI units and recommendations for the use of their multiples and of certain other units*

ISO 1219-1, *Fluid power systems and components — Graphic symbols and circuit diagrams — Part 1: Graphic symbols for conventional use and data-processing applications*

ISO 5598¹⁾, *Fluid power systems and components — Vocabulary*

ISO 6953-1, *Pneumatic fluid power — Compressed air pressure regulators and filter-regulators — Part 1: Main characteristics to be included in literature from suppliers and product-marking requirements*

ISO 19973-1, *Pneumatic fluid power — Assessment of component reliability by testing — Part 1: General procedures*

IEC 60050-191, *International Electrotechnical Vocabulary. Chapter 191: Dependability and quality of service*

1) Under revision.

3 Terms and definitions

For the purposes of this document, the terms and definitions given in ISO 5598, ISO 6953-1, ISO 19973-1, IEC 60050-191 and the following apply. Where a conflict of definitions exists for a term in any of these five documents, the following priority order shall apply: first, ISO 19973-4; second, ISO 19973-1; third, ISO 6953-1; fourth, ISO 5598; and fifth, IEC 60050-191.

3.1 body size

size of the regulator in relation to the size of its main ports: if the regulator has two main port sizes, the body size is related to the larger port size; if the regulator has three main port sizes, the body size is related to the middle port size

4 Symbols and units

- 4.1 The units of measurement are in accordance with ISO 1000.
- 4.2 The graphic symbols used in this part of ISO 19973 conform to the requirements of ISO 1219-1.

5 Test equipment

5.1 Basic test equipment

5.1.1 Each pressure regulator to be tested shall be installed in a test circuit that includes the components shown in Figure 1. Multiple test units of pressure regulators may use the same source of compressed air, but each test unit shall have identical components in its test circuit.

NOTE The basic circuit in Figure 1 does not incorporate all the safety devices necessary to protect against damage in the event of component failure. It is important that those responsible for carrying out the test give due consideration to safeguarding both personnel and equipment.

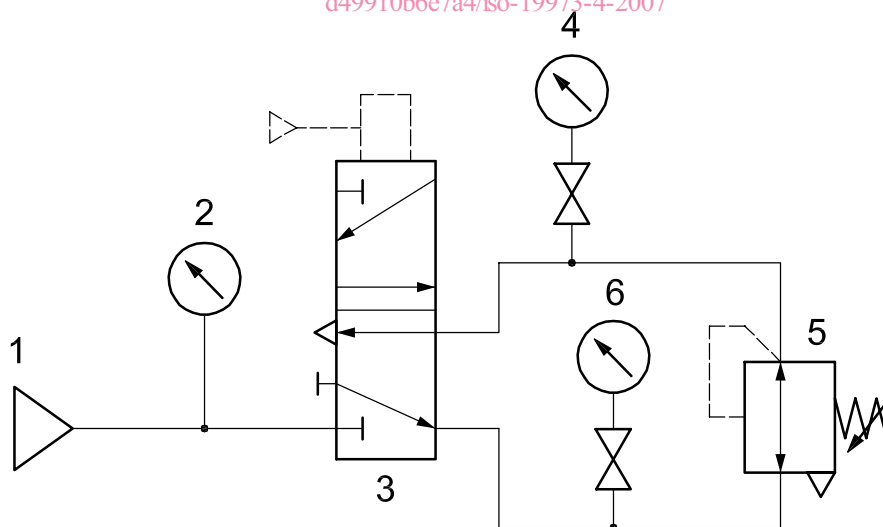

Key

- 1 supply
- 2 pressure gauge for measuring pressure p_1
- 3 five-port directional control valve
- 4 pressure-measuring unit and shut-off valve or quick-action coupling for measuring pressure p_3
- 5 pressure regulator under test (example)
- 6 pressure-measuring unit and shut-off valve or quick-action coupling for measuring pressure p_2

Figure 1 — Test circuit

5.1.2 The pressure regulator may be oriented in any position.

5.1.3 Install pressure gauges or pressure-recording devices into the test circuit, using either quick-action couplings or shut-off valves (see Figure 1, key items 4 and 6).

5.2 Directional control valve

An external pilot type or direct-operated type of directional control valve is used in the test circuit. The sonic conductance, C , of the directional control valve used shall ensure that the requirements of 7.4.1 b) will be reached.

5.3 Connecting piping

The outlet piping volume of the pressure regulator should be as small as possible.

6 Test conditions

6.1 General test conditions

General test conditions shall be in accordance with ISO 19973-1.

6.2 Inlet and outlet pressures

The inlet pressure for testing the regulators shall be $800 \text{ kPa} \pm 40 \text{ kPa}$.

The outlet pressure set point shall be $(80 \pm 5) \%$ of the inlet pressure or $(80 \pm 5) \%$ of the manufacturer's rated maximum outlet pressure, whichever is lower (see Figure 2, key item p_3).

NOTE To compensate for initial drift, it may be necessary to readjust the set point of the pressure regulator within 24 h before starting the test.

6.3 Pressure-cycle trace for the endurance test

Cycle the regulators in a manner to ensure that the outlet pressure drops below 10 %, and rises above 90 %, of the set pressure during the cycle (see Figure 2).

7 Test procedure

7.1 Selection of test units

NOTE See Annex A for a flow chart illustrating the test procedure specified in this clause.

Where several sizes of a regulator design use parts in common, select test units from the sizes that operate moving parts in the most severe manner. The control spring in each series which experiences the highest stress at the working pressure shall be tested. If the pressure regulator body has more than one port size (for example, ports of sizes 1/4, 3/8 and 1/2 in a single body), only one port size shall be tested.

7.2 Timing of checks and measurements

7.2.1 The following checks and measurements shall be made before the endurance test, at measuring intervals during the endurance test, and after the endurance test:

- a) functional check in accordance with 7.3.1;
- b) leakage measurement in accordance with 7.3.2.

7.2.2 The measuring intervals shall be determined in accordance with ISO 19973-1.