Ceramic tiles —

Part 4:

**Determination of modulus of rupture and
breaking strength**

Carreaux et dalles céramiques —

*Partie 4: Détermination de la résistance à la flexion et de la force de
rupture*

**iTeh STANDARD PREVIEW
(standards.iteh.ai)**

[ISO 10545-4:2004](https://standards.iteh.ai/catalog/standards/sist/b0d467db-dc82-45d1-912f-2940201d57bc/iso-10545-4-2004)

[https://standards.iteh.ai/catalog/standards/sist/b0d467db-dc82-45d1-912f-
2940201d57bc/iso-10545-4-2004](https://standards.iteh.ai/catalog/standards/sist/b0d467db-dc82-45d1-912f-2940201d57bc/iso-10545-4-2004)



PDF disclaimer

This PDF file may contain embedded typefaces. In accordance with Adobe's licensing policy, this file may be printed or viewed but shall not be edited unless the typefaces which are embedded are licensed to and installed on the computer performing the editing. In downloading this file, parties accept therein the responsibility of not infringing Adobe's licensing policy. The ISO Central Secretariat accepts no liability in this area.

Adobe is a trademark of Adobe Systems Incorporated.

Details of the software products used to create this PDF file can be found in the General Info relative to the file; the PDF-creation parameters were optimized for printing. Every care has been taken to ensure that the file is suitable for use by ISO member bodies. In the unlikely event that a problem relating to it is found, please inform the Central Secretariat at the address given below.

iTeh STANDARD PREVIEW
(standards.iteh.ai)

[ISO 10545-4:2004](https://standards.iteh.ai/catalog/standards/sist/b0d467db-dc82-45d1-912f-2940201d57bc/iso-10545-4-2004)

<https://standards.iteh.ai/catalog/standards/sist/b0d467db-dc82-45d1-912f-2940201d57bc/iso-10545-4-2004>

© ISO 2004

All rights reserved. Unless otherwise specified, no part of this publication may be reproduced or utilized in any form or by any means, electronic or mechanical, including photocopying and microfilm, without permission in writing from either ISO at the address below or ISO's member body in the country of the requester.

ISO copyright office
Case postale 56 • CH-1211 Geneva 20
Tel. + 41 22 749 01 11
Fax + 41 22 749 09 47
E-mail copyright@iso.org
Web www.iso.org

Published in Switzerland

Foreword

ISO (the International Organization for Standardization) is a worldwide federation of national standards bodies (ISO member bodies). The work of preparing International Standards is normally carried out through ISO technical committees. Each member body interested in a subject for which a technical committee has been established has the right to be represented on that committee. International organizations, governmental and non-governmental, in liaison with ISO, also take part in the work. ISO collaborates closely with the International Electrotechnical Commission (IEC) on all matters of electrotechnical standardization.

International Standards are drafted in accordance with the rules given in the ISO/IEC Directives, Part 2.

The main task of technical committees is to prepare International Standards. Draft International Standards adopted by the technical committees are circulated to the member bodies for voting. Publication as an International Standard requires approval by at least 75 % of the member bodies casting a vote.

Attention is drawn to the possibility that some of the elements of this document may be the subject of patent rights. ISO shall not be held responsible for identifying any or all such patent rights.

ISO 10545-4 was prepared by Technical Committee ISO/TC 189, *Ceramic tile*.

This second edition cancels and replaces the first edition (ISO 10545-4:1994), which has been technically revised.

ISO 10545 consists of the following parts, under the general title *Ceramic tiles*:

- *Part 1: Sampling and basis for acceptance*
- *Part 2: Determination of dimensions and surface quality*
- *Part 3: Determination of water absorption, apparent porosity, apparent relative density and bulk density*
- *Part 4: Determination of modulus of rupture and breaking strength*
- *Part 5: Determination of impact resistance by measurement of coefficient of restitution*
- *Part 6: Determination of resistance to deep abrasion for unglazed tiles*
- *Part 7: Determination of resistance to surface abrasion for glazed tiles*
- *Part 8: Determination of linear thermal expansion*
- *Part 9: Determination of resistance to thermal shock*
- *Part 10: Determination of moisture expansion*
- *Part 11: Determination of crazing resistance for glazed tiles*
- *Part 12: Determination of frost resistance*
- *Part 13: Determination of chemical resistance*
- *Part 14: Determination of resistance to stains*
- *Part 15: Determination of lead and cadmium given off by glazed tiles*
- *Part 16: Determination of small colour differences*

iTeh STANDARD PREVIEW
(standards.iteh.ai)

ISO 10545-4:2004

<https://standards.iteh.ai/catalog/standards/sist/b0d467db-dc82-45d1-912f-2940201d57bc/iso-10545-4-2004>

Ceramic tiles —

Part 4: Determination of modulus of rupture and breaking strength

1 Scope

This part of ISO 10545 specifies a test method for determining the modulus of rupture and breaking strength of all ceramic tiles.

NOTE ISO 13006 provides property requirements for tiles and other useful information on these products.

2 Normative references

The following referenced documents are indispensable for the application of this document. For dated references, only the edition cited applies. For undated references, the latest edition of the referenced document (including any amendments) applies.

ISO 48, *Rubber, vulcanized or thermoplastic — Determination of hardness (hardness between 10 IRHD and 100 IRHD)*

3 Terms and definitions

For the purposes of this document, the following terms and definitions apply.

3.1

breaking load

F_{bl}

force necessary to cause the test specimen to break, as read from the pressure gauge

NOTE 1 See 7.5 and Figure 2.

NOTE 2 The breaking load is expressed in newtons.

3.2

breaking strength

F_{bs}

force obtained by multiplying the breaking load by the ratio (span between support rods)/(width of the test specimen)

NOTE 1 See Equation (1) in Clause 8.

NOTE 2 The breaking strength is expressed in newtons.

3.3

modulus of rupture

$\sigma_{F_{bl}}$

quantity obtained by dividing the calculated breaking strength by the square of the minimum thickness along the broken edge

NOTE 1 See Equation (2) in Clause 8.

NOTE 2 The modulus of rupture is expressed in newtons per square millimetre.

4 Principle

Determination of the breaking load, breaking strength and modulus of rupture of a tile by applying a force at a specified rate to the centre of the tile, the point of application being in contact with the proper surface of the tile.

5 Apparatus

5.1 Drying oven, capable of being operated at $(110 \pm 5) \text{ }^\circ\text{C}$.

Microwave, infrared or other drying systems may be used provided that it has been determined that equal results are obtained.

5.2 Recording pressure gauge, accurate to 2,0 %.

5.3 Two cylindrical support rods, made of metal, the parts in contact with the test specimens being covered with rubber having a hardness of (50 ± 5) IRHD, measured in accordance with ISO 48.

One rod shall be slightly pivotable (see Figure 1) and the other shall be slightly rotatable about its own axis. (See Table 1 for relevant dimensions.)

5.4 Central cylindrical rod, of the same diameter as the support rods (5.3) and covered with the same rubber, for transmission of the load F_{bl} . (standards.iteh.ai)

This rod shall also be slightly pivotable (see Figure 1). (See Table 1 for relevant dimensions.)

<https://standards.iteh.ai/catalog/standards/sist/b0d467db-dc82-45d1-912f-2940201d57bc/iso-10545-4-2004>

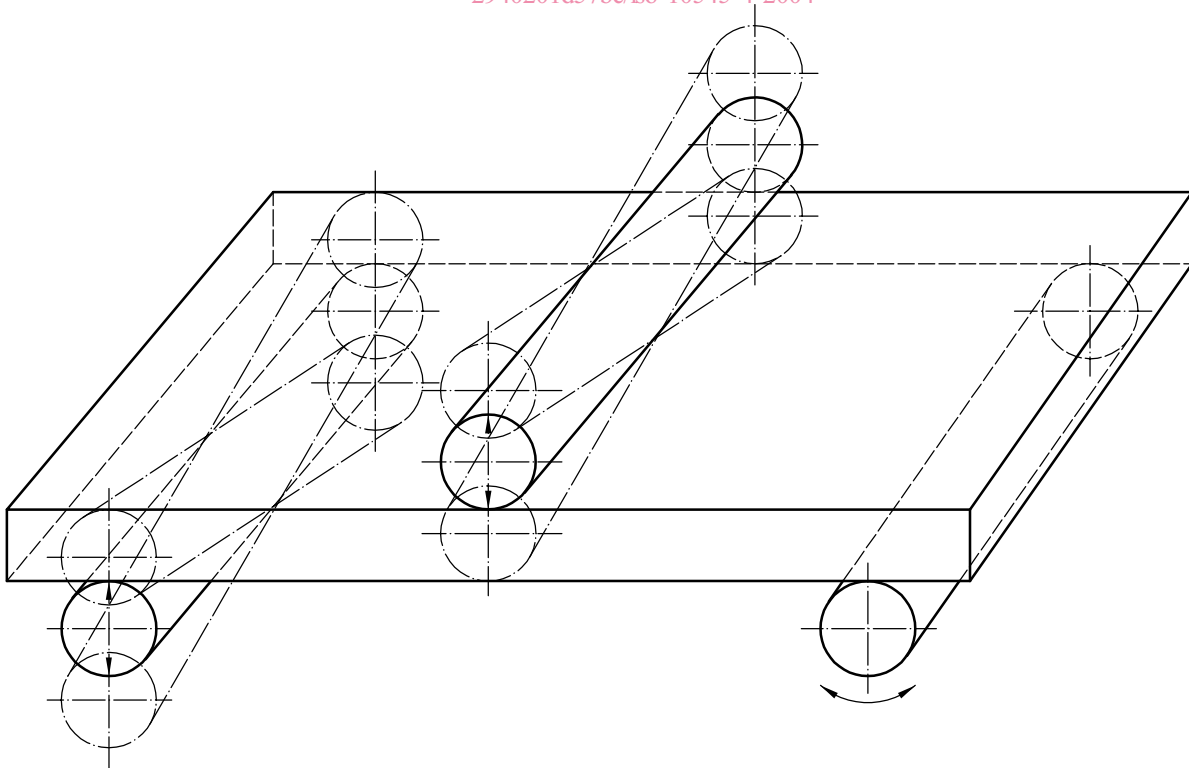
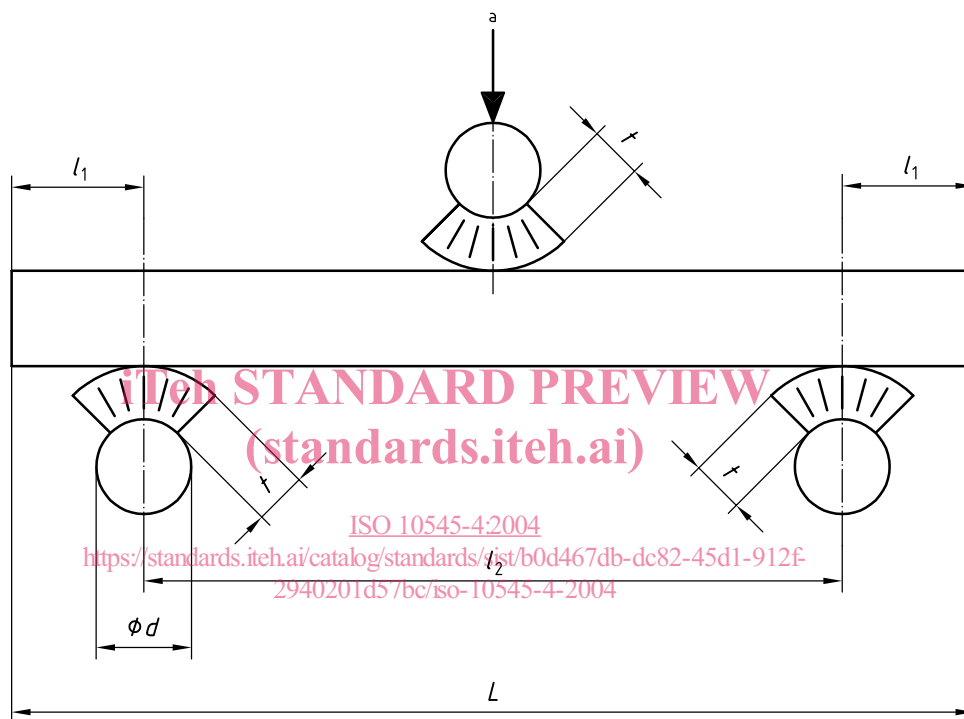

Figure 1 — Allowable movement of rods

Table 1 — Diameter of rods, d , thickness of rubber, t , and overlap of tile beyond the edge supports l_1 (see Figure 2)

Dimensions in millimetres

Dimension of tile L	Diameter of rod d	Thickness of rubber t	Overlap of tile beyond the edge supports l_1
$18 \leq L < 48$	5	$1 \pm 0,2$	2
$48 \leq L < 95$	10	$2,5 \pm 0,5$	5
$L \geq 95$	20	5 ± 1	10



^a F_{bl}

Figure 2 — Application of load to test specimen

6 Test specimens

6.1 Select the specimens at random from the lot to be tested. Whenever possible, whole tiles shall be tested. However, it may be necessary to cut exceptionally large tiles (that is, those greater than 300 mm in length) and some non-rectangular shapes in order to fit them in the apparatus. Rectangular test specimens of the largest possible size shall then be cut, having their centres coinciding with the centres of the tiles. In case of doubt, results obtained using whole tiles shall always be preferred to results obtained with cut tiles.

6.2 The minimum number of test specimens for each sample is given in Table 2.

Table 2 — Minimum number of test specimens

Dimension of tile <i>L</i> mm	Minimum number of test specimens
$18 \leq L < 48$	10
$L \geq 48$	7

7 Procedure

7.1 Remove any loosely adhering particles from the back of each test specimen with a stiff brush. Dry each test specimen in the oven (5.1) maintained at (110 ± 5) °C until constant mass is reached, i.e. when the difference between two successive weighings at intervals of 24 h is less than 0,1 %. The test specimens may be cooled in the closed oven or in a desiccator over silica gel or another suitable desiccant, but not over an acid, until they reach room temperature.

Test specimens shall be tested no later than 3 h after they have reached room temperature.

7.2 Place a test specimen on the support rods (5.3), with the glazed or proper surface uppermost so that the test specimen projects by a length l_1 (see Table 1 and Figure 2) beyond each support rod.

7.3 In the case of reversible tiles, such as unglazed ceramic mosaic tiles, it does not matter which side of the tile is uppermost. For extruded tiles, place the test specimen so that the projecting ribs are at right angles to the support rods. For all other rectangular tiles, place the test specimens so that the longer side, L , is at right angles to the support rods.

7.4 For tiles with a relief surface, place a second layer of rubber, of the appropriate thickness given in Table 1, on the central rod (5.4) in contact with the relief surface.

7.5 Position the central rod equidistant between the support rods. Apply the load evenly in such a way as to obtain a rate of increase in stress of $(1 \pm 0,2)$ N/mm² per second; the actual rate per second can be calculated by Equation (2) given in Clause 8. Record the breaking load F_{bl} .

8 Calculation

Use only the results for test specimens that break within a central portion of length equivalent to the diameter of the central rod to calculate the mean breaking strength and the mean modulus of rupture. A minimum of five acceptable results is necessary to calculate the mean value.

If there are fewer than five acceptable results, a second sample shall be tested consisting of twice the number of tiles. A minimum of 10 acceptable results is then required to calculate the average value.

The breaking strength F_{bs} , expressed in newtons, is calculated by means of Equation (1)

$$F_{bs} = \frac{F_{bl}l_2}{b} \tag{1}$$

where

F_{bl} is the breaking load, expressed in newtons;

l_2 is the span, expressed in millimetres, between the support rods (see Figure 2);

b is the width, expressed in millimetres, of the test specimen;

The modulus of rupture $\sigma_{F_{bl}}$, expressed in newtons per square millimetre, is calculated by means of Equation (2)

$$\begin{aligned}\sigma_{F_{bl}} &= \frac{3F_{bl}l_2}{2bh^2} \\ &= \frac{3F_{bs}}{2h^2}\end{aligned}\quad (2)$$

where

- F_{bl} is the breaking load, expressed in newtons;
- l_2 is the span, expressed in millimetres, between the support rods (see Figure 2);
- b is the width, expressed in millimetres, of the test specimen;
- h is the minimum thickness of the test specimen, expressed in millimetres, measured after the test along the broken edge.

The calculation of the modulus of rupture is based on a rectangular cross-section. In the case of tiles with variable thickness along the broken edge, approximate results only are produced. The shallower the relief, the more exact are the approximations.

Record all individual results.

Calculate the mean breaking strength and the mean modulus of rupture of the sample as the mean of the acceptable results.

iTech STANDARD PREVIEW
(standards.iteh.ai)

9 Test report

ISO 10545-4:2004

<https://standards.iteh.ai/catalog/standards/sist/b0d467db-dc82-45d1-912f-293201d576c1/iso-10545-4-2004>

The test report shall include the following information:

- a) reference to this part of ISO 10545 (ISO 10545-4:2004);
- b) description of the tiles, including relief surface, if any;
- c) number of test specimens in the sample;
- d) the values of d , t , l_1 and l_2 (see Figure 2);
- e) the breaking load F_{bl} of each test specimen;
- f) the mean breaking load;
- g) the breaking strength F_{bs} of each test specimen;
- h) the mean value of the breaking strength;
- i) the modulus of rupture $\sigma_{F_{bl}}$ of each test specimen;
- j) the mean value of the modulus of rupture.