



Standard Specification for Plastic Insert Fittings Utilizing a Copper Crimp Ring for SDR9 Cross-linked Polyethylene (PEX)¹

This standard is issued under the fixed designation F2159; the number immediately following the designation indicates the year of original adoption or, in the case of revision, the year of last revision. A number in parentheses indicates the year of last reapproval. A superscript epsilon (ϵ) indicates an editorial change since the last revision or reapproval.

1. Scope

1.1 This specification establishes requirements for sulfone plastic insert fittings and copper crimp rings for four sizes ($\frac{3}{8}$, $\frac{1}{2}$, and $\frac{3}{4}$ and 1) of cross-linked polyethylene (PEX) plastic tubing. These fittings are intended for use in 100 psi (690 kPa) cold- and hot-water distribution systems operating at temperatures up to and including 180°F (82°C). Included are the requirements for material, molded part properties, performance, workmanship, dimensions, and markings to be used on the fittings and rings.

1.2 *Units*—The values stated in inch-pound units are to be regarded as the standard. The values given in parentheses are mathematical conversions to SI units, which are provided for information only and are not considered the standard.

1.3 The following is an index of the appendix in this specification:

GO/NO-GO Crimp Gauges

Appendix X1

1.4 The following precautionary caveat pertains only to the test method portions, Sections 11 and 12, of this specification. *This standard does not purport to address all of the safety concerns, if any, associated with its use. It is the responsibility of the user of this standard to establish appropriate safety and health practices and determine the applicability of regulatory requirements prior to use.*

2. Referenced Documents

2.1 ASTM Standards:²

- D618 Practice for Conditioning Plastics for Testing
- D1598 Test Method for Time-to-Failure of Plastic Pipe Under Constant Internal Pressure
- D1599 Test Method for Resistance to Short-Time Hydraulic Pressure of Plastic Pipe, Tubing, and Fittings
- D1600 Terminology for Abbreviated Terms Relating to Plastics

¹ This specification is under the jurisdiction of ASTM Committee F17 on Plastic Piping Systems and is the direct responsibility of Subcommittee F17.10 on Fittings.

Current edition approved May 1, 2005. Published May 2005. Originally approved 2001. Last previous approved in 2003 as F2159-03^{e1}. DOI: 10.1520/F2159-05.

² For referenced ASTM standards, visit the ASTM website, www.astm.org, or contact ASTM Customer Service at service@astm.org. For *Annual Book of ASTM Standards* volume information, refer to the standard's Document Summary page on the ASTM website.

D2122 Test Method for Determining Dimensions of Thermoplastic Pipe and Fittings

D6394 Specification for Sulfone Plastics (SP)

F412 Terminology Relating to Plastic Piping Systems

F876 Specification for Crosslinked Polyethylene (PEX) Tubing

F877 Specification for Crosslinked Polyethylene (PEX) Plastic Hot- and Cold-Water Distribution Systems

F1498 Specification for Taper Pipe Threads 60° for Thermoplastic Pipe and Fittings

F1807 Specification for Metal Insert Fittings Utilizing a Copper Crimp Ring for SDR9 Cross-linked Polyethylene (PEX) Tubing

2.2 ASME Standard:

B 1.20.1 Pipe Threads General Purpose Inch³

2.3 NSF International Standard:

ANSI/NSF Standard No. 14 for Plastic Piping Components and Related Materials⁴

ANSI/NSF Standard No. 61 for Drinking Water System Components-Health Effects⁴

3. Terminology

3.1 *Definitions*—Definitions are in accordance with Terminology F412 and abbreviations are in accordance with Terminology D1600, unless otherwise indicated.

4. Classification

4.1 This specification governs one class of fittings and copper crimp rings suitable for use with nominal size $\frac{3}{8}$, $\frac{1}{2}$, $\frac{3}{4}$ and 1 size PEX tubing that meets the requirements of ASTM Specifications F876 or F877.

5. Materials and Manufacture

5.1 *Material*—Fittings shall be molded from sulfone plastic (SP) as specified in Specification D6394. The material shall be unreinforced polysulfone (group 01, class 1, grade 2) or polyphenylsulfone (group 03, class 1, grade 2). Material may also be an unreinforced blend of these two materials with the

³ Available from the American National Standards Institute, 11 West 42nd St., 13th Floor, New York, NY 10036.

⁴ Available from the National Sanitation Foundation (NSF International), P.O. Box 130140, Ann Arbor, MI 48113.

polyphenylsulfone continuous phase comprising 55 to 80 % of the blend. Fittings shall be made from virgin plastic or reworked plastic in accordance with 5.1.2.

5.1.1 *Discussion*—Since fittings specified by this standard will be used in hot-and-cold water plumbing systems, a material used to manufacture fittings in accordance with this specification must demonstrate qualities consistent with that application in addition to the performance requirements of this specification. Those qualifying characteristics include, but are not limited to, an established hydrostatic design basis (HDB) or stress design basis (SDB) in accordance with PPI TR-3 or similar rating and a demonstration of resistance to the long-term effects of those chemicals normally found in potable water at the maximum temperature stated in this specification.

5.1.2 *Rework Material*—Clean rework material of the same commercial designation, generated from the manufacturer’s own production may be used by the same manufacturer, provided the fittings meet all of the requirements of this specification. Reworked material shall not be introduced at a ratio exceeding 25 %.

5.2 *Potable Water Requirements*—Products intended for the transport of potable water shall be evaluated, tested and certified for conformance with ANSI/NSF Standard No. 61 or the health effects portion of ANSI/NSF Standard No. 14 by an acceptable certifying organization when required by the regulatory authority having jurisdiction.

5.3 *Crimp Rings*—Crimp rings shall be manufactured and marked in accordance with the requirements of Specification F1807.

6. Molded Part Properties

6.1 *Insert Crush*—The fitting insert shall not crack, split, or shatter when tested in accordance with 12.1.

6.2 *Splay*—The molded part shall be free of visible splay excepting some slight blushing at the gate location.

7. Performance Requirements

7.1 *General*—All performance tests shall be performed on assemblies of fittings, crimp rings, and PEX tubing. Fittings and crimp rings shall meet the material and dimensional requirements of this standard. PEX tubing shall meet the requirements of Specification F876 or F877. Assembly of test specimens shall be in accordance with Section 10. Use separate sets of assemblies for each performance test requirement.

7.2 *Hydrostatic Burst*—Assemblies shall meet the minimum hydrostatic burst requirements shown in Table 1, when tested in accordance with 11.5.

TABLE 1 Minimum Hydrostatic Burst Strength Requirements for Fitting, Crimp Ring, and PEX Tubing Assemblies

Nominal Tubing Size	Minimum Burst Pressures at Different Temperatures			
	psig ^A at 73.4°F	(kPa) at (23°C)	psig ^A at 180°F	(kPa) at (82.2°C)
in.				
3/8	620	(4275)	275	(1896)
1/2	480	(3309)	215	(1482)
3/4 and larger	475	(3275)	210	(1448)

^A The fiber stress to derive this test pressure is: at 73.4°F (23.0°C) 1900 psi (13.10 MPa) at 180°F (82.2°C) 850 psi (5.86 MPa).

7.3 *Hydrostatic Sustained Pressure Strength*—Assemblies shall meet the hydrostatic sustained pressure requirements shown in Table 2 when tested in accordance with 11.6.

7.4 *Thermocycling*—Assemblies shall not leak or separate when thermocycled 1000 cycles between the temperatures of 60°F (16°C) and 180°F (82°C) when tested in accordance with 11.7.

7.5 *Excessive Temperature-Pressure Capability:*

7.5.1 *General*—Assemblies shall have adequate strength to accommodate short-term conditions, 30 days (720 h) of 210° F (99° C) and 150 psi (1034 kPa) when tested in accordance with 11.8.

8. Dimensions

8.1 *Dimensions and Tolerances*—The dimensions and tolerances of fittings shall be as shown in Fig. 1, when measured in accordance with 11.4.

8.1.1 *Alignment*—The maximum angular variation of any opening shall not exceed 1° off the true centerline axis.

8.1.2 *Tapered Threads*—Fitting threads shall be American National Standard Taper Pipe Thread Form conforming to Specification F1498.

8.1.3 *Straight Threads*—Straight pipe threads, intended for the making of a gasketed seal with taper pipe threads, shall be NPSM and conform to ASME B 1.20.1.

9. Workmanship, Finish and Appearance

9.1 The sealing surfaces of the insert shall be smooth and free of foreign material. The fitting walls shall be free of cracks, holes, blisters, voids, foreign inclusions, or other defects that are visible to the unaided eye and that affect the wall integrity.

9.2 Except for the insert, the molded part shall be free of flash in excess of 0.005 in. Flash, mismatch, and witness mark requirements for the insert shall be in accordance with Fig. 1.

10. Assembly

10.1 *Crimp Joints*—Insert fittings shall be joined to PEX tubing by the compression of a copper crimp ring around the outer circumference of the tubing forcing the tubing material into annular spaces formed by ribs on the fitting. Insert fittings and crimp rings shall meet the dimensional and material requirements of this standard. PEX tubing shall meet the requirements of Specifications F876 or F877. The dimensions and out-of-roundness of the crimp ring after it has been crimped shall be in accordance with Table 3.

TABLE 2 Minimum Hydrostatic Sustained Pressure Requirements for Fitting, Crimp Ring and PEX Tubing Assemblies^{A,B}

Nominal Tubing Size	Pressure Required for Test, psig (kPa)	
	180°F	(82.2°C)
in.		
3/8	250	(1724)
1/2	195	(1344)
3/4 and larger	190	(1310)

^A The fiber stress to derive this test pressure is: 770 psi (5.31 MPa) at 180° F (82.2°C).

^B Test duration is 1000 h.

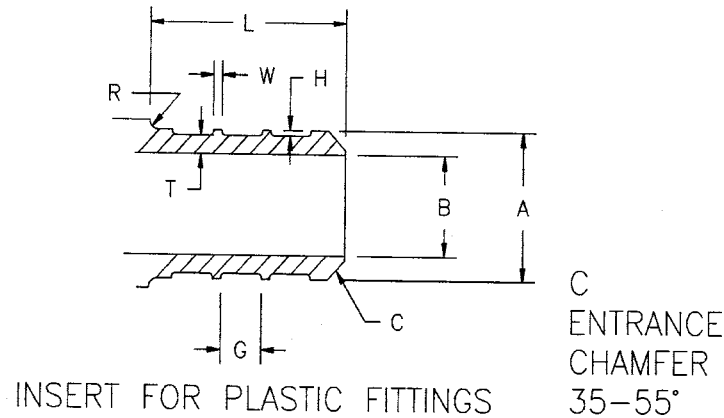

SIZE	A OUTSIDE DIAMETER	B MINIMUM ID	L INSERT LENGTH ^A	H MINIMUM RIB HEIGHT	NUMBER OF RIBS ^B	W RIB WIDTH TYP	G GAP WIDTH TYP	T MINIMUM WALL ^A	R MINIMUM RADIUS	MAXIMUM FLASH AND MISMATCH TOTAL ON CREST DIAMETER ^{C,D}
3/8"	0.347±.003	0.197	0.70+.020	0.015	2	0.03-0.05	0.135- 0.152	0.050	0.03	0.005
1/2"	0.473±.003	0.315	0.70+.020	0.015	2	0.03-0.05	0.135- 0.152	0.056	0.03	0.005
3/4"	0.668±.003	0.460	0.70+.020	0.015	2	0.03-0.05	0.135- 0.152	0.082	0.03	0.005
1"	0.856±.003	0.610	0.85+.020	0.015	3	0.03-0.05	0.135- 0.152	0.100	0.03	0.005

^A APPLIES TO ENTIRE FITTING NOT JUST INSERT AREA.
^B FITTING SHALL BE DESIGNED WITH SUFFICIENT OVERALL DIMENSIONS TO ALLOW PROPER USE OF CRIMP TOOL WITHOUT INTERFERENCE WITH PREVIOUSLY COMPLETED CRIMPS ON THE SAME FITTING.
^C THE MAXIMUM FLASH AND MISMATCH AT THE ROOT DIAMETER BETWEEN THE RIBS MAY NOT EXCEED 30% OF THE RIB HEIGHT.
^D THE TOTAL FLASH AND MISMATCH IS ASSUMED TO BE THE DIFFERENCE BETWEEN THE DIMENSIONS X AND Y (SEE FIG. 1A). THESE DIMENSIONS MAY BE MEASURED WITH APPROPRIATE CALIPERS OR MICROMETERS. SEE FIG. 1B FOR A GRAPHIC DEFINITION OF FLASH AND MISMATCH CREATED BY IMPERFECTION IN DIE HALF INTERFACES.
^E LEAD CHAMFER AREA IS NOT CONSIDERED A RIB.
^F THE MINIMUM ID SHALL BE MAINTAINED THROUGH THE INSERT LENGTH AND INTO THE FITTING, INTERSECTING THE MINIMUM ID OF THE OTHER FITTING INSERT(S).

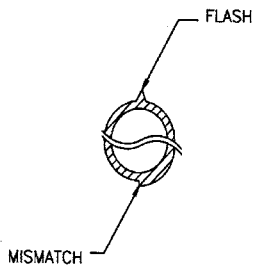

FIG. 1A FLASH AND MISMATCH CREATED BY IMPERFECTION IN DIE HALF INTERFACES.

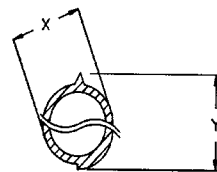

FIG. 1B TOTAL FLASH AND MISMATCH

FIG. 1 Fitting Insert Dimensions and Tolerances

10.1.1 *Crimping Procedure*—To affix the insert fitting to the tubing with the crimp ring, the crimping procedure shall be as follows: slide the crimp ring onto the tubing, insert the ribbed end of the fitting into the end of the tubing until the tubing contacts the shoulder of the fitting or tube stop. The crimp ring shall then be positioned on the tubing so the edge of the crimp

ring is 1/8 in. to 1/4 in. (3.2 to 6.4 mm) from the end of the tube. The jaws of the crimping tool shall be centered over the crimp ring and the tool shall be held so that the crimping jaws are approximately perpendicular to the axis of the barb. The jaws of the crimping tool shall be closed around the crimp ring, compressing the crimp ring onto the tubing. The crimp ring