**Timber structures — Glued laminated
timber — Methods of test for glue-line
delamination**

*Structures en bois — Bois lamellé-collé — Méthodes d'essai de
décollement des plans de collage*

iTeh STANDARD PREVIEW
(standards.iteh.ai)

[ISO 12580:2007](https://standards.iteh.ai/catalog/standards/sist/1c2de525-9739-45ad-8895-0cc3c78ddca0/iso-12580-2007)

[https://standards.iteh.ai/catalog/standards/sist/1c2de525-9739-45ad-8895-
0cc3c78ddca0/iso-12580-2007](https://standards.iteh.ai/catalog/standards/sist/1c2de525-9739-45ad-8895-0cc3c78ddca0/iso-12580-2007)



PDF disclaimer

This PDF file may contain embedded typefaces. In accordance with Adobe's licensing policy, this file may be printed or viewed but shall not be edited unless the typefaces which are embedded are licensed to and installed on the computer performing the editing. In downloading this file, parties accept therein the responsibility of not infringing Adobe's licensing policy. The ISO Central Secretariat accepts no liability in this area.

Adobe is a trademark of Adobe Systems Incorporated.

Details of the software products used to create this PDF file can be found in the General Info relative to the file; the PDF-creation parameters were optimized for printing. Every care has been taken to ensure that the file is suitable for use by ISO member bodies. In the unlikely event that a problem relating to it is found, please inform the Central Secretariat at the address given below.

iTeh STANDARD PREVIEW
(standards.iteh.ai)

[ISO 12580:2007](https://standards.iteh.ai/catalog/standards/sist/1c2de525-9739-45ad-8895-0cc3c78ddca0/iso-12580-2007)

<https://standards.iteh.ai/catalog/standards/sist/1c2de525-9739-45ad-8895-0cc3c78ddca0/iso-12580-2007>



COPYRIGHT PROTECTED DOCUMENT

© ISO 2007

All rights reserved. Unless otherwise specified, no part of this publication may be reproduced or utilized in any form or by any means, electronic or mechanical, including photocopying and microfilm, without permission in writing from either ISO at the address below or ISO's member body in the country of the requester.

ISO copyright office
Case postale 56 • CH-1211 Geneva 20
Tel. + 41 22 749 01 11
Fax + 41 22 749 09 47
E-mail copyright@iso.org
Web www.iso.org

Published in Switzerland

Contents

Page

Foreword.....	iv
Introduction	v
1 Scope	1
2 Terms and definitions.....	1
3 Symbols and abbreviated terms	1
4 Principle.....	1
5 Apparatus	2
5.1 Pressure vessel for methods A, B, C.....	2
5.2 Boiling and cooling vessels for method D.....	2
5.3 Drying duct for methods A, B, C, D, E.....	2
6 Preparation of test pieces.....	2
7 Procedure	3
7.1 General.....	3
7.2 Test cycle for method A.....	4
7.3 Test cycle for method B.....	4
7.4 Test cycle for method C.....	4
7.5 Test cycle for method D.....	5
7.6 Test cycle for method E.....	5
8 Results	5
8.1 General.....	5
8.2 Total delamination	6
8.3 Maximum delamination	6
9 Test report	6
Bibliography	7

Foreword

ISO (the International Organization for Standardization) is a worldwide federation of national standards bodies (ISO member bodies). The work of preparing International Standards is normally carried out through ISO technical committees. Each member body interested in a subject for which a technical committee has been established has the right to be represented on that committee. International organizations, governmental and non-governmental, in liaison with ISO, also take part in the work. ISO collaborates closely with the International Electrotechnical Commission (IEC) on all matters of electrotechnical standardization.

International Standards are drafted in accordance with the rules given in the ISO/IEC Directives, Part 2.

The main task of technical committees is to prepare International Standards. Draft International Standards adopted by the technical committees are circulated to the member bodies for voting. Publication as an International Standard requires approval by at least 75 % of the member bodies casting a vote.

Attention is drawn to the possibility that some of the elements of this document may be the subject of patent rights. ISO shall not be held responsible for identifying any or all such patent rights.

ISO 12580 was prepared by Technical Committee ISO/TC 165, *Timber structures*.

iTeh STANDARD PREVIEW (standards.iteh.ai)

[ISO 12580:2007](https://standards.iteh.ai/catalog/standards/sist/1c2de525-9739-45ad-8895-0cc3c78ddca0/iso-12580-2007)

<https://standards.iteh.ai/catalog/standards/sist/1c2de525-9739-45ad-8895-0cc3c78ddca0/iso-12580-2007>

Introduction

This International Standard was developed by TC 165 as a factory quality-assurance test to be used for structural glulam. It is intended that it be used in conjunction with ISO 12578 and be applied to each production batch. The frequency of testing and the pass/fail criteria are detailed in ISO 12578. However, there is nothing in principle that would prevent the test method from being applied to non-structural glulam.

iTeh STANDARD PREVIEW (standards.iteh.ai)

[ISO 12580:2007](https://standards.iteh.ai/catalog/standards/sist/1c2de525-9739-45ad-8895-0cc3c78ddca0/iso-12580-2007)

<https://standards.iteh.ai/catalog/standards/sist/1c2de525-9739-45ad-8895-0cc3c78ddca0/iso-12580-2007>

iTeh STANDARD PREVIEW
(standards.iteh.ai)

ISO 12580:2007

<https://standards.iteh.ai/catalog/standards/sist/1c2de525-9739-45ad-8895-0cc3c78ddca0/iso-12580-2007>

Timber structures — Glued laminated timber — Methods of test for glue-line delamination

1 Scope

This International Standard specifies five delamination methods for factory quality assurance of the glue line of glued laminated timber.

2 Terms and definitions

For the purposes of this document, the following terms and definitions apply.

2.1

delamination length

sum of the lengths of open glue lines on both end-grain surfaces of each test piece

2.2

glued laminated timber (glulam)

structural member formed by bonding together timber laminations with their grain essentially parallel

2.3

gauge pressure

NOTE Atmospheric pressure at sea level approximates 100 kPa.

<https://standards.iteh.ai/catalog/standards/sist/1c2de525-9739-45ad-8895-0cc3c78ddca0/iso-12580-2007>

3 Symbols and abbreviated terms

b : width of cross-section, in millimetres;

h : depth of cross-section, in millimetres;

$l_{\text{max, delam}}$: maximum delamination length of one glue line in the test piece, measured on both end grain surfaces of the test specimen, in millimetres, see Figure 1;

$l_{\text{glue line}}$: length of one glue line, normally the width b , in millimetres, see Figure 1;

$l_{\text{tot, delam}}$: delamination length of all glue lines on the two end-grain surfaces in the test piece, in millimetres;

$l_{\text{tot, glue line}}$: entire length of glue lines on the two end-grain surfaces of each test piece, in millimetres.

4 Principle

A gradient is introduced in the moisture content of the wood to build up internal stresses. This results in tensile stresses perpendicular to the glue lines, so that an inadequate bonding quality will result in delamination of the glue lines.

5 Apparatus

5.1 Pressure vessel for methods A, B, C

A pressure vessel designed to safely withstand a gauge pressure of at least 600 kPa and a gauge vacuum of at least 85 kPa, and equipped with pumps or similar devices capable of giving the required pressure and vacuum are required.

5.2 Boiling and cooling vessels for method D

Boiling and cooling vessels, of sufficient size to hold the specimens so that they are completely submerged, are required.

5.3 Drying duct for methods A, B, C, D, E

A drying duct capable of circulating air at a velocity of 2 m/s to 3 m/s at the temperatures and relative humidities given in Table 1 is required.

Table 1 — Climate in the drying duct for the different methods

Method (see 7.2 to 7.6)	Drying temperature °C	Relative humidity %
A	60 to 70	< 15
B	65 to 75	8 to 10
C	25 to 30	25 to 35
D	67 to 73	8 to 10
E	67 to 73	8 to 10

6 Preparation of test pieces

The test pieces shall be prepared or selected in such a manner that they are representative of the production run.

Each test piece shall be taken from a full cross-section of the glued laminated timber to be tested, prepared by cutting perpendicular to the grain of the wood. It shall be (75 ± 5) mm in length (along the grain). The end-grain surfaces of the test piece shall be cut with a sharp saw or tool that produces a smooth surface.

If the width b of the cross-section is greater than 300 mm, it is permissible to split the test piece into two or more test pieces, each at least 130 mm wide. If the depth h is greater than 600 mm, the test piece(s) may be cut into two or more pieces, each with a depth of at least 300 mm (Figure 1).

Dimensions in millimetres

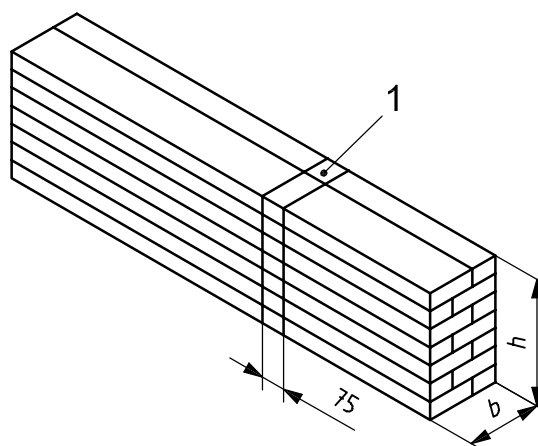
**Key**

1 rectangular test specimen

Figure 1 — Test specimen cut from a glulam member**7 Procedure**

iTeh STANDARD PREVIEW
(standards.iteh.ai)

7.1 General

The total length of glue lines on the end-grain surfaces of the test pieces shall be measured to the nearest millimetre.

The test pieces shall be weighed and subjected to the appropriate test cycle described in 7.2 to 7.6. The number of test cycles shall be as given in Table 2.

Table 2 — Number of test cycles to be used in the different test methods

Method	Number of initial cycles	Number of extra cycles
A	1	1
B	1	1
C	1	0
D	2	0
E	2	0

An extra test cycle shall be carried out for methods A and B, if the total delamination percentage according to 8.2 is larger than the prescribed maximum value upon completion of the required initial cycles.

Within a maximum of one h after the end of the final drying period, the length of open glue lines on the end-grain surfaces of the test pieces shall be measured. Open glue lines at knots shall be ignored and failure in the wood due to checking or other causes shall not be included as delamination. Isolated delamination less than 3 mm long and more than 5 mm away from the nearest delamination shall also be ignored.