



Designation: D 2582 – 00

## Standard Test Method for Puncture-Propagation Tear Resistance of Plastic Film and Thin Sheeting<sup>1</sup>

This standard is issued under the fixed designation D 2582; the number immediately following the designation indicates the year of original adoption or, in the case of revision, the year of last revision. A number in parentheses indicates the year of last reapproval. A superscript epsilon ( $\epsilon$ ) indicates an editorial change since the last revision or reapproval.

### 1. Scope \*

1.1 This test method covers the determination of the dynamic tear resistance of plastic film and thin sheeting subjected to end-use snagging-type hazards.

1.2 The values stated in SI units are to be regarded as the standard. The values given in parentheses are for information only.

1.3 *This standard does not purport to address all of the safety concerns, if any, associated with its use. It is the responsibility of the user of this standard to establish appropriate safety and health practices and determine the applicability of regulatory limitations prior to use.*

NOTE 1—There is no equivalent ISO test method.

### 2. Referenced Documents

#### 2.1 ASTM Standards:

D 618 Practice for Conditioning Plastics and Electrical Insulating Materials for Testing<sup>2</sup>

D 883 Terminology Relating to Plastics<sup>2</sup>

D 4000 Classification System for Specifying Plastic Materials<sup>3</sup>

D 4805 Terminology for Plastics Standards<sup>4</sup>

D 5947 Test Methods for Physical Dimensions of Solid Plastic Specimens<sup>4</sup>

E 691 Practice for Conducting an Interlaboratory Study to Determine the Precision of a Test Method<sup>5</sup>

### 3. Terminology

#### 3.1 Descriptions of Terms Specific to This Standard:

3.1.1 *slit tear*—a single tear parallel to the direction of the falling carriage.

3.1.2 “*V*” *tear*—a tear that has two individual tear legs (not necessarily of equal length) radiating approximately  $\pm 45^\circ$  from the point the tear was initiated.

### 4. Significance and Use

4.1 The puncture-propagation of tear test measures the resistance of a material to snagging, or more precisely, to dynamic puncture and propagation of that puncture resulting in a tear. Failures due to snagging occur in a variety of end uses, including industrial bags, liners, and tarpaulins. The units reported in this test method are Newtons (tear resistance).

4.2 Experience has shown that for many materials puncture does not contribute significantly to the force value determined, due to the sharpness of the propagating probe used. However, comparing the results of prepunctured test specimens with normal nonpunctured specimens will give an indication of the extent of any puncture resistance in the reported result.

4.3 For many materials, there may be a specification that requires the use of this test method, but with some procedural modifications that take precedence when adhering to the specification. Therefore, it is advisable to refer to that material specification before using this test method. Table 1 of Classification System D 4000 lists the current ASTM materials standards.

### 5. Apparatus

5.1 As shown in Fig. 1, the instrument consists of:

5.1.1 Carriages of different weight, each with a pointed probe. Each carriage weight shall have a tolerance of  $\pm 1\%$  of the weight desired.

5.1.2 A test stand including:

5.1.2.1 Carriage release mechanism,

5.1.2.2 Scale marked in millimetres,

5.1.2.3 Curved specimen holder with a tear slot and five clamps,

5.1.2.4 Drop base with a guide channel to accommodate the carriage wheels, and

5.1.2.5 Bubble level to level the base.

5.2 The standard drop height is 508 mm (20.0 in.); however, it can be varied to suit the desired end-use-rate condition. See 10.3 for an alternative method for calculating tear resistance for heights other than 508 mm.

5.3 The probe is a 3.18-mm (0.125-in.) diameter drill rod having one end a truncated cone, the short base 0.40 mm (0.016 in.) in diameter, with a  $30^\circ$  included angle so that most

<sup>1</sup> This test method is under the jurisdiction of ASTM Committee D20 on Plastics and is the direct responsibility of Subcommittee D20.19 on Film and Sheeting.

Current edition approved April 10, 2000. Published July 2000. Originally published as D 2582 – 67. Last previous edition D 2582 – 93.

<sup>2</sup> *Annual Book of ASTM Standards*, Vol 08.01.

<sup>3</sup> *Annual Book of ASTM Standards*, Vol 08.02.

<sup>4</sup> *Annual Book of ASTM Standards*, Vol 08.03.

<sup>5</sup> *Annual Book of ASTM Standards*, Vol 14.02.

\*A Summary of Changes section appears at the end of this standard.

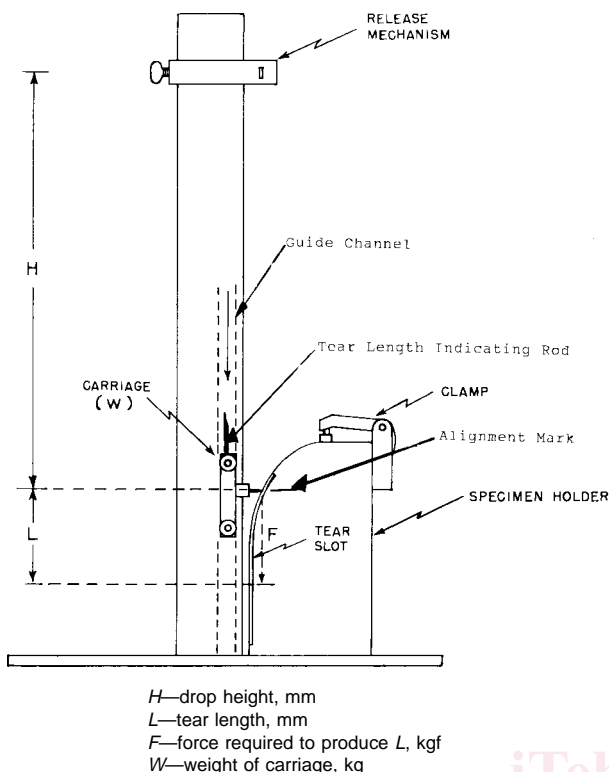

**FIG. 1 Puncture-Propagation of Tear Tester**

of the tear is propagated against the body of the rod. See Fig. 2.

5.4 *Thickness Gage*— a dead-weight micrometer as described in Test Method C of Test Method D 5947, or an equivalent measuring device, reading to 0.0025 mm (0.0001 in.) or less.

**6. Test Specimen**

6.1 Specimens can be cut in any rectangular shape so long as they are approximately 200 mm (8.0 in.) long in the direction of tear and can be held by all five clamps. Multiple tears can be made on a single sheet provided a minimum separation of 25 mm (1 in.) is maintained between tears.

6.2 Two sets of specimens shall be cut from each sample such that the direction of tear, during the test, will be parallel

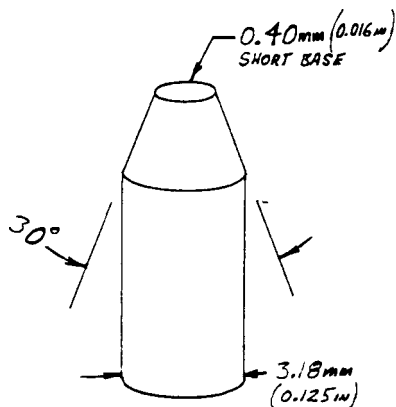

**FIG. 2 Short Base Probe**

to (1) MD, the machine direction and (2) TD, the transverse direction, respectively, of the material being tested. Enough specimens shall be cut in each direction to provide for a minimum of five tears.

**7. Preparation and Calibration of Apparatus**

7.1 Level the base of the tester by centering the spirit level bubble by adjustment of the leveling legs.

7.2 Check “sharpness” of probes by visual observation under a magnifying glass. If the short base end is not 0.40 mm (0.016 in.) in diameter or any burrs, nicks, or distortions are noted, or both, replace the probe.

7.3 Check the length of the probes by inserting each carriage in turn in the guide channel and lowering to the alignment mark on the curved specimen holder. The point of the probe should be aligned with this mark.

7.4 Measure the vertical drop height from the specimen holder mark, located near the tear slot, to the horizontal mark on the carriage release mechanism. Adjust the selected height to the nearest 2 mm (0.078 in.). The standard drop height is 508 ± 2 mm.

7.5 Check the alignment of the specimen holder receiving slot by lowering a carriage with its probe extending into the slot, up and down the slot length. The probe should be centered, that is, not touching either edge of the slot.

**8. Conditioning**

8.1 *Conditioning*—Condition the test specimens at 23 ± 2°C (73.4 ± 3.6°F) and 50 ± 5 % relative humidity for not less than 40 hours prior to test in accordance with Procedure A of Practice D 618 for those tests where conditioning is required. In cases of disagreement, the tolerances shall be ± 1°C (± 1.8°F) and ± 2 % relative humidity.

8.2 *Test Conditions*—Conduct tests in the standard laboratory atmosphere of 23 ± 2°C (73.4 ± 3.6°F) and 50 ± 5 % relative humidity, unless otherwise specified in the material specification. In cases of disagreement, the tolerances shall be ± 1°C (± 1.8°F) and ± 2 % relative humidity.

**9. Procedure**

9.1 Measure and record the thickness of each specimen tested. Read the thickness to 0.0025 mm (0.0001 in.) or better, except for sheeting greater than 0.25 mm (0.010 in.), which shall be measured to a precision of 0.025 mm (0.001 in.) or better.

9.2 Secure the specimen in the holder by placing it under the clamps and setting the clamp lever to the down position. The specimen should drape against the holder contour. Stiffer materials should be loosely held adjacent to the holder. Each clamp should apply sufficient pressure to prevent any specimen slippage.

9.3 By trial and error, select the carriage that produces a minimum tear length of 40 mm and does not bottom-out against the drop base. Lower selected carriage until the probe point touches but does not indent the specimen. Adjust the tear length indicating rod to “0” on the scale located on the guide channel.

9.4 Place the selected carriage in the release mechanism.

9.5 Cock the release mechanism on the left side and release