



Designation: D3944 – 88 (Reapproved 2005)

Standard Test Method for Solidification Point of Petroleum Wax¹

This standard is issued under the fixed designation D3944; the number immediately following the designation indicates the year of original adoption or, in the case of revision, the year of last revision. A number in parentheses indicates the year of last reapproval. A superscript epsilon (ϵ) indicates an editorial change since the last revision or reapproval.

1. Scope

1.1 This test method covers a procedure for rapidly determining the solidification point of petroleum wax.

NOTE 1—This test method is also applicable to similar materials such as synthetic waxes but the precision may vary.

1.2 The values stated in SI units are to be regarded as the standard. The values given in parentheses are for information only.

1.3 *This standard does not purport to address all of the safety problems, if any, associated with its use. It is the responsibility of the user of this standard to establish appropriate safety and health practices and determine the applicability of regulatory limitations prior to use.*

2. Referenced Documents

2.1 *ASTM Standards:*²

D87 Test Method for Melting Point of Petroleum Wax (Cooling Curve)

D127 Test Method for Drop Melting Point of Petroleum Wax, Including Petrolatum

D938 Test Method for Congealing Point of Petroleum Waxes, Including Petrolatum

E1 Specification for ASTM Liquid-in-Glass Thermometers

3. Terminology

3.1 *Definitions: Related to This Standard:*

3.2 *solidification point of petroleum wax*—that temperature in the cooling curve of the wax where the slope of the curve first changes significantly as the wax sample changes from a liquid to a solid state.

4. Summary of Test Method

4.1 A 50-mg sample of wax is placed in a test tube at ambient temperature and heated above the solidification point

¹ This test method is under the jurisdiction of ASTM Committee D02 on Petroleum Products and Lubricants and is the direct responsibility of Subcommittee D02.10.0A on Physical/Chemical Properties.

Current edition approved May 1, 2005. Published May 2005. Originally approved in 1980. Last previous edition approved in 2000 as D3944 – 88 (2000). DOI: 10.1520/D3944-88R05.

² For referenced ASTM standards, visit the ASTM website, www.astm.org, or contact ASTM Customer Service at service@astm.org. For *Annual Book of ASTM Standards* volume information, refer to the standard's Document Summary page on the ASTM website.

of the wax sample. A thermocouple probe, attached to a recorder, is inserted into the wax sample, which is allowed to cool at room temperature. The thermocouple response of the cooling wax traces a curve on the chart paper of the recorder. The first significant change in the slope of the curve is the solidification point.

5. Significance and Use

5.1 The related methods of determining the melt point of petroleum wax are relatively time-consuming. This method endeavors to reduce the duration of testing significantly and at the same time maintain a reasonable precision. This method can be useful for quality control of petroleum waxes as well as research and product development work on these waxes.

5.2 For methods used for testing melt points of petroleum waxes, see Tests Method D87, D127, including Petrolatum and Test Method D938.

6. Apparatus

6.1 *Thermocouple*, with an iron-constantan junction.³

6.2 *Recorder* capable of recording voltage and equipped with a time-base module. The recorder should have the following minimum specifications:

6.2.1 *Span*, 0 to 10 mV or other suitable ranges.

6.2.2 *Accuracy*, 0.25 % of full scale.

6.2.3 *Step Response Time*, 1-s full scale, 3-s full scale is also appropriate.

6.2.4 *Zero Junction/Reference Junction/Temperature Compensated Junction*—Must be included.

6.3 *TFE-Fluorocarbon Holder Adapter*—See Fig. 1 and Fig. 2.⁴

6.4 *TFE-Fluorocarbon Disk Centering Guide*—See Fig. 1 and Fig. 2.⁴

³ Suitable thermocouples are available from: Claud S. Gordon Co., 5710 Kenosha St., Richmond, IL 60071, (815) 678-2211. For "J" (iron-constantan) junction the following is suitable: Xactpak Type MM Assembly, Catalog No. 402-1101.

Junction: grounded (G)

Transition fitting: TH 2780-020

Thermocouple wire: J30-1-305

L (length of metal sheath)

E (lead length): specify length desired.

⁴ Not commercially available and hence must be made in a machine shop or elsewhere.

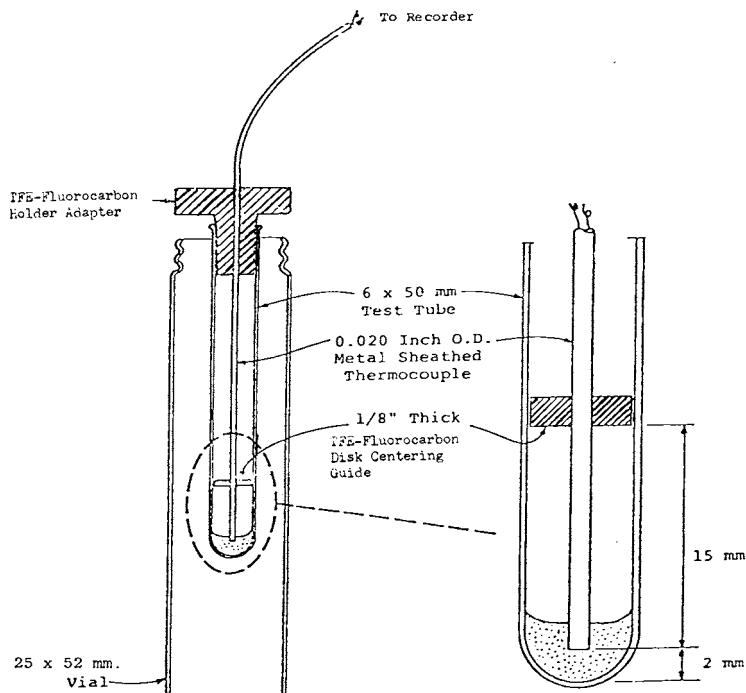

FIG. 1 Solidification Point Apparatus

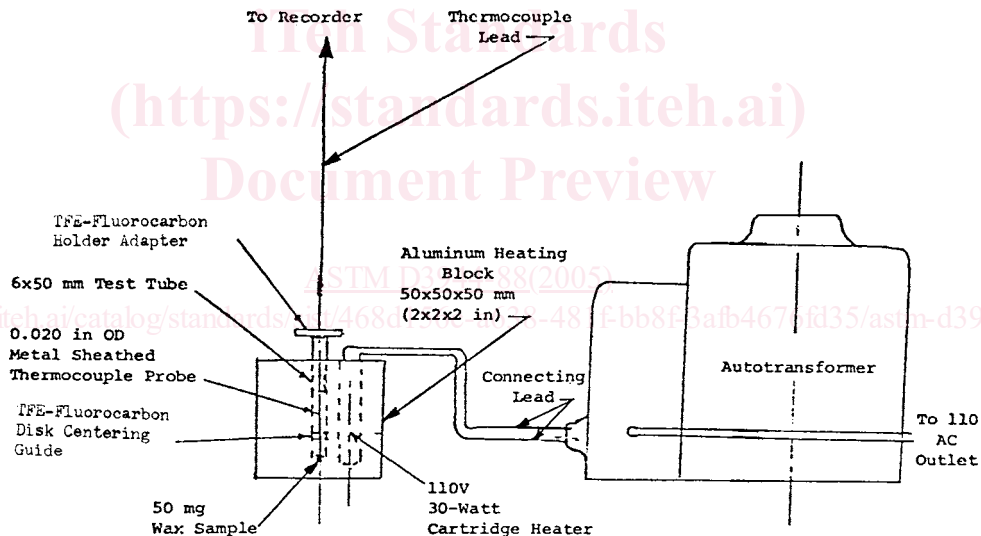

FIG. 2 Apparatus for Heating Wax Sample

6.5 Test Tubes, 6 by 50-mm.

6.6 Vial, 25 by 52-mm.

6.7 Apparatus for Calibrating Temperature Recorder:

6.7.1 Stainless Steel Beaker, 1000-mL.

6.7.2 Heating Mantle, to fit 6.7.1.

6.7.3 Autotransformer to control heat to 6.7.2.

6.7.4 Variable-Speed-Stirrer.

6.7.5 Thermometer, ASTM No. 61C or 61F, 79-mm immersion.

6.8 Methods for Heating Specimen:

6.8.1 Hot Air Blower at 1000 W, 1200 W, or other suitable power. This could be a laboratory or a household hair dryer type.

6.8.2 Aluminum Heating Block, about 50 by 50 by 50 mm.

In the center of one face of the block, a hole is made 7 mm in diameter and 37 mm deep to accommodate a 6 by 50-mm test tube and another hole adjacent to it to accommodate a 110-V, 30-W cartridge heater, about 9 by 38 mm, commercially available (see Fig. 2).

6.8.2.1 Autotransformer, to control heat in 6.8.2.

7. Procedure

7.1 Calibrate the recorder at least every 60 days when in frequent use (see Annex A1).

7.2 Obtain a wax sample representative of the material to be tested.