



SLOVENSKI STANDARD
kSIST FprEN ISO 3691-2:2015
01-oktober-2015

Vozila za talni transport - Varnostne zahteve in preverjanje - 2. del: Samognana vozila s spremenljivim dosegom (ISO/FDIS 3691-2:2015)

Industrial trucks - Safety requirements and verification - Part 2: Self-propelled variable-reach trucks (ISO/FDIS 3691-2:2015)

Flurförderzeuge - Sicherheitsanforderungen und Verifizierung - Teil 2: Motorkraftbetriebene Flurförderzeuge mit veränderlicher Reichweite (ISO/FDIS 3691-2:2015)

Chariots de manutention - Exigences de sécurité et vérification - Partie 2: Chariots automoteurs à portée variable (ISO/FDIS 3691-2:2015)

Ta slovenski standard je istoveten z: FprEN ISO 3691-2

ICS:

53.060 Industrijski tovornjaki Industrial trucks

kSIST FprEN ISO 3691-2:2015 en

FINAL
DRAFTINTERNATIONAL
STANDARDISO/FDIS
3691-2

ISO/TC 110/SC 2

Secretariat: SIS

Voting begins on:
2015-08-20Voting terminates on:
2015-10-20**Industrial trucks — Safety
requirements and verification —****Part 2:
Self-propelled variable-reach trucks***Chariots de manutention — Exigences de sécurité et vérification —**Partie 2: Chariots automoteurs à portée variable*iTeh STANDARD PREVIEW
(standards.iteh.ai)SIST EN ISO 3691-2:2016<https://standards.iteh.ai/catalog/standards/sist/d2dd9a79-4c8a-4f8a-903d-66780e474d63/sist-en-iso-3691-2-2016>**Please see the administrative notes on page iii**

RECIPIENTS OF THIS DRAFT ARE INVITED TO SUBMIT, WITH THEIR COMMENTS, NOTIFICATION OF ANY RELEVANT PATENT RIGHTS OF WHICH THEY ARE AWARE AND TO PROVIDE SUPPORTING DOCUMENTATION.

IN ADDITION TO THEIR EVALUATION AS BEING ACCEPTABLE FOR INDUSTRIAL, TECHNOLOGICAL, COMMERCIAL AND USER PURPOSES, DRAFT INTERNATIONAL STANDARDS MAY ON OCCASION HAVE TO BE CONSIDERED IN THE LIGHT OF THEIR POTENTIAL TO BECOME STANDARDS TO WHICH REFERENCE MAY BE MADE IN NATIONAL REGULATIONS.

Reference number
ISO/FDIS 3691-2:2015(E)

© ISO 2015

ISO/CEN PARALLEL PROCESSING

This final draft has been developed within the International Organization for Standardization (ISO), and processed under the **ISO-lead** mode of collaboration as defined in the Vienna Agreement. The final draft was established on the basis of comments received during a parallel enquiry on the draft.

This final draft is hereby submitted to the ISO member bodies and to the CEN member bodies for a parallel two-month approval vote in ISO and formal vote in CEN.

Positive votes shall not be accompanied by comments.

Negative votes shall be accompanied by the relevant technical reasons.

iTeh STANDARD PREVIEW (standards.iteh.ai)

[SIST EN ISO 3691-2:2016](https://standards.iteh.ai/catalog/standards/sist/d2dd9a79-4c8a-4f8a-903d-66780e474d63/sist-en-iso-3691-2-2016)

<https://standards.iteh.ai/catalog/standards/sist/d2dd9a79-4c8a-4f8a-903d-66780e474d63/sist-en-iso-3691-2-2016>



COPYRIGHT PROTECTED DOCUMENT

© ISO 2015, Published in Switzerland

All rights reserved. Unless otherwise specified, no part of this publication may be reproduced or utilized otherwise in any form or by any means, electronic or mechanical, including photocopying, or posting on the internet or an intranet, without prior written permission. Permission can be requested from either ISO at the address below or ISO's member body in the country of the requester.

ISO copyright office
Ch. de Blandonnet 8 • CP 401
CH-1214 Vernier, Geneva, Switzerland
Tel. +41 22 749 01 11
Fax +41 22 749 09 47
copyright@iso.org
www.iso.org

Contents

	Page
Foreword	vi
Introduction	vii
1 Scope	1
2 Normative references	1
3 Terms and definitions	3
4 Safety requirements and/or protective measures	5
4.1 General.....	5
4.1.1 Overall requirements.....	5
4.1.2 Normal climatic conditions.....	5
4.1.3 Normal operating conditions.....	5
4.1.4 Sharp edges.....	6
4.1.5 Electrical requirements.....	6
4.1.6 Stored energy components.....	6
4.2 Starting/moving.....	6
4.2.1 Unauthorized starting.....	6
4.2.2 Unintended movement and inadvertent activation.....	6
4.3 Brakes.....	6
4.3.1 General.....	6
4.3.2 Failure of energy supply.....	7
4.4 Manual control actuator.....	7
4.4.1 General.....	7
4.4.2 Travel and braking controls.....	7
4.4.3 Steering controls.....	8
4.4.4 Load-handling controls.....	8
4.4.5 Other controls.....	9
4.4.6 Marking.....	9
4.5 Power systems and accessories.....	9
4.5.1 Exhaust system.....	9
4.5.2 Cooling system.....	9
4.5.3 Fuel tanks.....	9
4.5.4 Access to engine and other compartments.....	10
4.5.5 Liquefied petroleum gas (LPG)-powered trucks.....	10
4.6 Systems for telescoping, lifting and tilting.....	12
4.6.1 Lift chains.....	12
4.6.2 Hydraulic lifting, telescoping and carriage tilting.....	13
4.6.3 Hydraulic systems.....	14
4.6.4 Fork arms.....	14
4.6.5 Fork-arm extensions.....	14
4.6.6 Fork carriers.....	14
4.6.7 Load-handling attachments.....	15
4.7 Operator positions.....	15
4.7.1 Dimensions.....	15
4.7.2 Operator's seat.....	15
4.7.3 Operator restraint.....	16
4.7.4 Operator access and egress.....	16
4.7.5 Protection from road wheels and objects thrown up by the wheels.....	17
4.7.6 Protection from burning.....	17
4.7.7 Protection against crushing, shearing and trapping.....	17
4.8 Stability.....	17
4.8.1 General.....	17
4.8.2 Specific operating conditions.....	18
4.8.3 Longitudinal stability determination.....	18
4.9 Protective devices.....	18

ISO/FDIS 3691-2:2015(E)

4.9.1	Overhead guard.....	18
4.9.2	Load backrest extension.....	18
4.9.3	Roll-over protective structures.....	19
4.9.4	Warning device.....	19
4.9.5	Starter battery requirements.....	19
4.10	Visibility and lighting.....	19
4.10.1	Visibility.....	19
4.10.2	Lighting.....	19
4.11	Operator's cab.....	19
4.11.1	General.....	19
4.11.2	Doors and windows.....	19
4.11.3	Fire resistance.....	20
4.11.4	Ventilation.....	20
4.11.5	Heating, air conditioning and ventilation system.....	20
4.11.6	Air filters.....	21
4.11.7	Demisting and defrosting.....	21
4.11.8	Pressurization system.....	21
4.11.9	Wipers and washers.....	21
4.11.10	Access and an emergency exit.....	22
4.11.11	Storage of instruction handbook.....	22
4.11.12	Additional operator's position.....	22
4.12	Provisions for transportation of the truck and removable attachments.....	22
4.13	Environmental requirements.....	22
4.13.1	Noise emissions.....	22
4.13.2	Vibration.....	22
4.13.3	Electromagnetic compatibility (EMC).....	23
4.14	Devices for towing.....	23
5	Verification of safety requirements and/or protective measures.....	23
5.1	General.....	23
5.2	Structural verification.....	23
5.2.4	Test loads.....	23
5.2.5	Static test.....	23
5.3	Dynamic testing.....	24
5.3.1	Purpose.....	24
5.3.2	Test procedure.....	24
5.3.3	Acceptance criteria.....	24
5.4	Functional verification.....	24
6	Information for use.....	25
6.1	General.....	25
6.2	Instruction handbook.....	25
6.2.1	Truck/attachments.....	25
6.2.2	Operation of truck.....	25
6.2.3	Details for battery powered trucks.....	26
6.2.4	Details for internal-combustion-engine powered trucks.....	26
6.2.5	Service and maintenance.....	27
6.2.6	Transportation, commissioning and storage.....	27
6.2.7	Truck modification.....	27
6.3	Marking.....	28
6.3.1	Information plates.....	28
6.3.2	Load chart.....	29
6.3.3	Information plate for trucks operating in special conditions.....	31
6.3.4	Other information.....	31
6.3.5	Languages.....	32
6.3.6	Operator restraint.....	32
Annex A (informative)	Rated capacity of truck.....	33
Annex B (informative)	List of significant hazards.....	36

Annex ZA (informative) Relationship between this International Standard and the Essential Requirements of Directive 2006/42/EC	42
Bibliography	43

iTeh STANDARD PREVIEW
(standards.iteh.ai)

[SIST EN ISO 3691-2:2016](https://standards.iteh.ai/catalog/standards/sist/d2dd9a79-4c8a-4f8a-903d-66780e474d63/sist-en-iso-3691-2-2016)

<https://standards.iteh.ai/catalog/standards/sist/d2dd9a79-4c8a-4f8a-903d-66780e474d63/sist-en-iso-3691-2-2016>

ISO/FDIS 3691-2:2015(E)

Foreword

ISO (the International Organization for Standardization) is a worldwide federation of national standards bodies (ISO member bodies). The work of preparing International Standards is normally carried out through ISO technical committees. Each member body interested in a subject for which a technical committee has been established has the right to be represented on that committee. International organizations, governmental and non-governmental, in liaison with ISO, also take part in the work. ISO collaborates closely with the International Electrotechnical Commission (IEC) on all matters of electrotechnical standardization.

The procedures used to develop this document and those intended for its further maintenance are described in the ISO/IEC Directives, Part 1. In particular the different approval criteria needed for the different types of ISO documents should be noted. This document was drafted in accordance with the editorial rules of the ISO/IEC Directives, Part 2 (see www.iso.org/directives).

Attention is drawn to the possibility that some of the elements of this document may be the subject of patent rights. ISO shall not be held responsible for identifying any or all such patent rights. Details of any patent rights identified during the development of the document will be in the Introduction and/or on the ISO list of patent declarations received (see www.iso.org/patents).

Any trade name used in this document is information given for the convenience of users and does not constitute an endorsement.

For an explanation on the meaning of ISO specific terms and expressions related to conformity assessment, as well as information about ISO's adherence to the WTO principles in the Technical Barriers to Trade (TBT) see the following URL: [Foreword - Supplementary information](#)

The committee responsible for this document is ISO/TC 110, *Industrial trucks*, Subcommittee SC 2, *Safety of powered industrial trucks*.

ISO 3691 consists of the following parts, under the general title *Industrial trucks — Safety requirements and verification*: <https://standards.iteh.ai/catalog/standards/sist/d2dd9a79-4c8a-4f8a-903d-66780e474d63/sist-en-iso-3691-2-2016>

- *Part 1: Self-propelled industrial trucks, other than driverless, variable-reach and burden-carrier trucks*
- *Part 2: Self-propelled variable-reach trucks*
- *Part 3: Additional requirements for trucks with elevating operator position and trucks specifically designed to travel with elevated loads*
- *Part 4: Driverless industrial trucks and their systems*
- *Part 5: Pedestrian-propelled trucks*
- *Part 6: Burden and personnel carriers*
- *Part 7: Regional requirements for countries within the European Community* [Technical Specification]
- *Part 8: Regional requirements for countries outside the European Community* [Technical Specification]

Introduction

General

This document is a type-C standard as stated in ISO 12100.

The machines concerned and the extent to which hazards, hazardous situations or hazardous events are covered are indicated in the Scope of this document.

When requirements of this type-C standard are different from those which are stated in type-A or B standards, the requirements of this type-C standard take precedence over the requirements of the other standards for machines that have been designed and built according to the requirements of this type-C standard.

The ISO 3691- series of standards covers safety requirements and their verification for industrial trucks as defined in ISO 5053-1.

Structure

An important step forward in the work on the ISO 3691- series of standards was the agreement to issue a new structure of International Standards for industrial trucks having on one side basic standards for all kinds of trucks (see Foreword) and on the other side independent standards to cover the respective specific functions of industrial trucks, e.g. visibility, noise, vibration, electrical requirements, etc.

Assessment of hazards

The product needs to be designed in such a way that it is fit for its purpose or function and can be adjusted and maintained without putting persons at risk when used under the conditions foreseen by the manufacturer.

In order to properly design a product and to cover all specific safety requirements, the manufacturer will have to identify the hazards that apply to his product and carry out a risk assessment. The manufacturer will then need to design and construct the product taking this assessment into account.

The aim of this procedure is to eliminate the risk of accidents throughout the foreseeable lifetime of the machinery, including the phases of assembling and dismantling where risks of accidents could also arise from foreseeable abnormal situations.

In selecting the most appropriate methods, the manufacturer will need to apply the following principles, in the order given here:

- a) eliminate or reduce risks as far as possible by design (inherently safe machinery design and construction);
- b) take the necessary protective measures in relation to risks that cannot be eliminated by design;
- c) inform users of any shortcoming of the protective measures adopted;
- d) indicate whether any particular training is required;
- e) specify any need to provide personal protection equipment;
- f) refer to the appropriate user's document for proper operating instructions.

Industrial trucks need to be designed to prevent foreseeable misuse wherever possible, if such would engender risk. In other cases, the instructions will need to draw the user's attention to ways shown by experience in which the machinery ought not to be used.

This part of ISO 3691 does not repeat all the technical rules which are state-of-the art and which are applicable to the material used to construct the industrial truck. Reference will also need to be made to ISO 12100.

ISO/FDIS 3691-2:2015(E)

Legislative situation/Vienna Agreement

From the very beginning, the task of the working group was to revise ISO 3691:1980 and establish worldwide basic standards to comply with the major legislative regulations in, for example, the EU, Japan, Australia and North America.

Every effort was made to develop a globally relevant International Standard. That goal was achieved with most of the issues. For several potential problem areas compromises were needed and will be needed in the future. Where divergent regional requirements remain, these are addressed by ISO/TS 3691-7 and ISO/TS 3691-8.

In order to ensure that the revised International Standard will be actively used in the ISO member countries, worldwide, procedures will be necessary to replace the existing national standards and technical regulations by the revised International Standard. In the European Community, ISO and the European Committee for Standardization (CEN) agreed on technical co-operation under the Vienna Agreement, with the aim of replacing European Standards (EN) by International Standards. Other countries are asked to make similar agreements to ensure that their national standards and technical regulations are replaced by this International Standard.

Only by these actions will there be the guarantee that products in accordance with International Standards can be shipped worldwide freely without any technical barriers.

iTeh STANDARD PREVIEW (standards.iteh.ai)

[SIST EN ISO 3691-2:2016](https://standards.iteh.ai/catalog/standards/sist/d2dd9a79-4c8a-4f8a-903d-66780e474d63/sist-en-iso-3691-2-2016)

<https://standards.iteh.ai/catalog/standards/sist/d2dd9a79-4c8a-4f8a-903d-66780e474d63/sist-en-iso-3691-2-2016>

Industrial trucks — Safety requirements and verification —

Part 2: Self-propelled variable-reach trucks

1 Scope

This part of ISO 3691 gives safety requirements and the means for their verification for self-propelled industrial variable-reach trucks and variable-reach container handlers/reach stackers as defined in ISO 5053-1 (hereafter referred to as *trucks*), equipped with forks or integral load-handling devices for normal industrial duties (e.g. fork arms or means, such as spreaders, for handling containers).

It is not applicable to

- rough-terrain variable-reach trucks,
- rough-terrain variable-reach trucks for handling containers,
- machines designed primarily for earth-moving (e.g. loaders and dozers), even when their buckets and blades are replaced with forks,
- machines from which the load can swing freely in all directions.

For the purposes of this part of ISO 3691, fork arms and integrated attachments are considered to be a part of the truck, whereas attachments/equipment mounted on the load carrier or on the fork arms which are removable by the user are not. Nevertheless, requirements for such attachments are also given by the document.

Any regional requirements additional to the provisions of this part of ISO 3691 are addressed in ISO/TS 3691-7 and ISO/TS 3691-8.

This part of ISO 3691 deals with all significant hazards, hazardous situations or hazardous events, as listed in [Annex B](#), with the exception of the following, relevant to the applicable machines when used as intended and under conditions of misuse which are reasonably foreseeable by the manufacturer.

It does not establish requirements for hazards that can occur

- during construction,
- when using trucks on public roads,
- when operating in potentially explosive atmospheres, or
- when lifting persons.

2 Normative references

The following documents, in whole or in part, are normatively referenced in this document and are indispensable for its application. For dated references, only the edition cited applies. For undated references, the latest edition of the referenced document (including any amendments) applies.

ISO 2328, *Fork-lift trucks — Hook-on type fork arms and fork arm carriages — Mounting dimensions*

ISO 2330, *Fork-lift trucks — Fork arms — Technical characteristics and testing*

ISO/FDIS 3691-2:2015(E)

ISO 2867, *Earth-moving machinery — Access systems*

ISO 3287, *Powered industrial trucks — Symbols for operator controls and other displays*

ISO/TS 3691-7, *Industrial trucks — Safety requirements and verification — Part 7: Regional requirements for countries within the European Community*

ISO/TS 3691-8, *Industrial trucks — Safety requirements and verification — Part 8: Regional requirements for countries outside the European Community*

ISO 3411:2007, *Earth-moving machinery — Physical dimensions of operators and minimum operator space envelope*

ISO 3795, *Road vehicles, and tractors and machinery for agriculture and forestry — Determination of burning behaviour of interior materials*

ISO 4413, *Hydraulic fluid power — General rules and safety requirements for systems and their components*

ISO 5053-1, *Industrial trucks — Terminology and classification — Part 1: Types of industrial trucks*

ISO 5353, *Earth-moving machinery, and tractors and machinery for agriculture and forestry — Seat index point*

ISO 6055:2004, *Industrial trucks — Overhead guards — Specification and testing*

ISO 6292, *Powered industrial trucks and tractors — Brake performance and component strength*

ISO 10263-2, *Earth-moving machinery — Operator enclosure environment — Part 2: Air filter element test method*

ISO 10263-3, *Earth-moving machinery — Operator enclosure environment — Part 3: Pressurization test method*

ISO 10263-4, *Earth-moving machinery — Operator enclosure environment — Part 4: Heating, ventilating and air conditioning (HVAC) test method and performance*

ISO 12100:2010, *Safety of machinery — General principles for design — Risk assessment and risk reduction*

ISO 13284, *Fork-lift trucks — Fork-arm extensions and telescopic fork arms — Technical characteristics and strength requirements*

ISO 13564-1, *Powered industrial trucks — Test methods for verification of visibility — Part 1: Sit-on and stand-on operator trucks and variable-reach trucks up to and including 10 t capacity*

ISO 15870, *Powered industrial trucks — Safety signs and hazard pictorials — General principles*

ISO 15871, *Industrial trucks — Specifications for indicator lights for container handling and grapples arm operations*

ISO 21281, *Construction and layout of pedals of self-propelled sit-down rider-controlled industrial trucks — Rules for the construction and layout of pedals*

ISO 22915-1, *Industrial trucks — Verification of stability — Part 1: General*

ISO 22915-10, *Industrial trucks — Verification of stability — Part 10: Additional stability test for trucks operating in the special condition of stacking with load laterally displaced by powered devices*

ISO 22915-11, *Industrial trucks — Verification of stability — Part 11: Industrial variable-reach trucks*

ISO 22915-12, *Industrial trucks — Verification of stability — Part 12: Industrial variable-reach trucks handling freight containers of 6 m (20 ft) length and longer*

ISO 22915-20, *Industrial trucks — Verification of stability — Part 20: Additional stability test for trucks operating in the special condition of offset load, offset by utilization*

ISO 24135-1, *Industrial trucks — Specifications and test methods for operator restraint systems — Part 1: Lap-type seat belts*

3 Terms and definitions

For the purposes of this document, the terms and definitions given in ISO 5053-1 and ISO 12100, and the following apply.

3.1

self-propelled industrial variable-reach truck

seated-rider-operated, counterbalanced lift truck with one or more articulated arms, telescopic, non-slewing, used for stacking loads and for operation on smooth, level, prepared and consolidated surfaces

3.2

actual capacity at maximum lift height with forks

maximum load, Q_2 , specified by the manufacturer that the truck is capable of lifting to its maximum height in normal operating conditions

Note 1 to entry: It is equal to the maximum load, with centre of gravity G (see [Figure A.1](#)), carried on the *fork arms* ([3.7](#)) at the standard load centre distance, D , as specified in [Annex A](#), and with the *boom* ([3.9](#)) adjusted to its maximum height. It is expressed in kilograms.

3.3

actual capacity at container position with spreader

maximum load, Q , with row (d) and height (h), specified by the manufacturer that the truck is capable of lifting to its maximum height in normal operating conditions

3.4

axle locking

mechanism designed to stop oscillation of the rear axle so as to improve truck stability

3.5

stabilizer

extendable or pivoting mechanical supports used to improve stability of a stationary truck

3.6

lateral levelling

act of changing the angular relationship between the boom pivot and the ground in order to adjust the boom pivot to horizontal when the truck is standing on a side slope

Note 1 to entry: Used to ensure that the *boom* ([3.9](#)) operates in a vertical plane.

3.7

fork arms

device consisting of two or more solid forks, hook-mounted or shaft-mounted, that is fitted on the carriage and usually spread manually

3.8

fork arm extension

device fitted over the *fork arms* ([3.7](#)) to increase their length

3.9

boom

pivoting support member providing radial and telescoping (if equipped) movement of the load-engaging means

ISO/FDIS 3691-2:2015(E)

**3.10
spreader**

device fitted to the *boom* (3.9), designed to connect the lifting points of freight containers, swap bodies and semi-trailers

Note 1 to entry: It can include powered devices used to connect the lifting points of the load and an articulated mechanism to facilitate engagement.

**3.11
bucket**

device intended for carrying bulk products such as sand, gravel or coal

**3.12
overhead guard**

device fitted to the truck for the purpose of protecting the operator against falling objects

**3.13
load backrest**

portion of the fork carriage serving to restrain the load when the load is tilted rearward or upward

**3.14
normal operating position**

position in which the operator is able to control all functions for driving and load handling as defined by the manufacturer

Note 1 to entry: Additional positions may be defined by the manufacturer if it is not possible to control all the functions of the truck from a single position. A rotating seat or stand-up end-control truck with more than one operating direction is considered as being or having a single operating position.

**3.15
fork carrier**

device fitted at the end of the *boom* (3.9) to connect and lock interchangeable attachments without the use of a tool

**3.16
auxiliary mast**

mast at the end of the *boom* (3.9) intended for reaching greater lifting heights

Note 1 to entry: Referred to simply as *mast* in this part of ISO 3691.

**3.17
non-slewing**

having a slewing movement not greater than 5° on either side of the longitudinal axis of the truck

Note 1 to entry: See Figure 1.

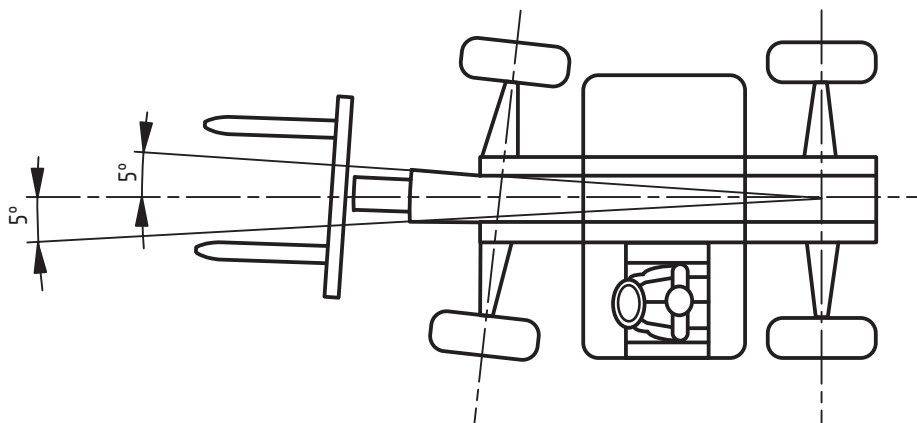

Figure 1 — Slewing movement $\leq 5^\circ$ (non-slewing)

3.18**rated capacity with fork arms**

load, Q_1 , in kilograms, permitted by the manufacturer, that the truck type is capable of transporting and lifting in normal operating conditions with the boom fully retracted

Note 1 to entry: For centre of gravity G.

Note 2 to entry: The rated capacity is used to compare the capacity of different manufacturers' trucks and to provide the break points used in technical standards and statistics. The operating limits for the truck are defined by the *actual capacity* (3.2, 3.3).

3.19**rated capacity with spreader**

load, Q_1 , in kilograms, permitted by the manufacturer that the truck type is capable of transporting and lifting in normal operating conditions with the spreader in the position of the first container row at measurement d_1 and lift height 6,5 m

Note 1 to entry: For the second container, see [Figure A.2](#).

4 Safety requirements and/or protective measures**4.1 General****4.1.1 Overall requirements**

The truck shall comply with the safety requirements and/or protective measures of this clause.

In addition, the truck shall be designed according to the principles of ISO 12100:2010 for relevant but not significant hazards which are not dealt with by this document.

4.1.2 Normal climatic conditions

For truck operation, the following climatic conditions apply:

- average ambient temperature for continuous duty: + 25 °C;
- maximum ambient temperature, short term (up to 1 h): + 40 °C;
- lowest ambient temperature for trucks intended for use in normal indoor conditions: + 5 °C;
- lowest ambient temperature for trucks intended for use in normal outdoor conditions: – 20 °C;
- altitude: up to 2 000 m.

4.1.3 Normal operating conditions

Normal operating conditions are the following:

- driving (travelling and lifting) on substantially firm, smooth, level and prepared surfaces — the surface conditions on which the truck is designed to operate shall be specified in the instruction handbook (see [6.2](#));
- driving with the horizontal load centre of gravity approximately on the longitudinal centre plane of the truck;
- travelling with the mast or fork arms tilted backwards, where applicable, and the load in the lowered (travel) position.

If the above is not sufficient to allow the conditions for stability of a particular truck type to be specified, then the operating conditions shall be according to the International Standards referenced for stability in [4.8](#).