**Rubber and plastics hoses and tubing —
Determination of transmission of liquids
through hose and tubing walls**

*Tuyaux et tubes en caoutchouc et en plastique — Détermination de la
transmission des liquides à travers les parois des tuyaux et des tubes*

iTeh STANDARD PREVIEW
(standards.iteh.ai)

[ISO 8308:2006](https://standards.iteh.ai/catalog/standards/sist/aea78083-9965-416e-8077-8395a21e007c/iso-8308-2006)

[https://standards.iteh.ai/catalog/standards/sist/aea78083-9965-416e-8077-
8395a21e007c/iso-8308-2006](https://standards.iteh.ai/catalog/standards/sist/aea78083-9965-416e-8077-8395a21e007c/iso-8308-2006)



PDF disclaimer

This PDF file may contain embedded typefaces. In accordance with Adobe's licensing policy, this file may be printed or viewed but shall not be edited unless the typefaces which are embedded are licensed to and installed on the computer performing the editing. In downloading this file, parties accept therein the responsibility of not infringing Adobe's licensing policy. The ISO Central Secretariat accepts no liability in this area.

Adobe is a trademark of Adobe Systems Incorporated.

Details of the software products used to create this PDF file can be found in the General Info relative to the file; the PDF-creation parameters were optimized for printing. Every care has been taken to ensure that the file is suitable for use by ISO member bodies. In the unlikely event that a problem relating to it is found, please inform the Central Secretariat at the address given below.

iTeh STANDARD PREVIEW
(standards.iteh.ai)

[ISO 8308:2006](#)

<https://standards.iteh.ai/catalog/standards/sist/aea78083-9965-416e-8077-8395a21e007c/iso-8308-2006>

© ISO 2006

All rights reserved. Unless otherwise specified, no part of this publication may be reproduced or utilized in any form or by any means, electronic or mechanical, including photocopying and microfilm, without permission in writing from either ISO at the address below or ISO's member body in the country of the requester.

ISO copyright office
Case postale 56 • CH-1211 Geneva 20
Tel. + 41 22 749 01 11
Fax + 41 22 749 09 47
E-mail copyright@iso.org
Web www.iso.org

Published in Switzerland

Contents

Page

1	Scope	1
2	Normative references	1
3	Principle	1
3.1	Method A	1
3.2	Method B	1
4	Test liquid	1
5	Method A	2
5.1	Apparatus	2
5.2	Test pieces	3
5.3	Test temperature	3
5.4	Test pressure	3
5.5	Procedure	3
5.6	Expression of results	4
5.7	Test report	4
6	Method B	4
6.1	Apparatus	4
6.2	Test piece	4
6.3	Test temperature	5
6.4	Procedure	5
6.5	Expression of results	7
6.6	Test report	7

ITeH STANDARD PREVIEW
(standards.iteh.ai)

ISO 8308:2006

<https://standards.iteh.ai/catalog/standards/sist/aea78083-9965-416e-8077->

<6395a21e007c/iso-8308-2006>

Foreword

ISO (the International Organization for Standardization) is a worldwide federation of national standards bodies (ISO member bodies). The work of preparing International Standards is normally carried out through ISO technical committees. Each member body interested in a subject for which a technical committee has been established has the right to be represented on that committee. International organizations, governmental and non-governmental, in liaison with ISO, also take part in the work. ISO collaborates closely with the International Electrotechnical Commission (IEC) on all matters of electrotechnical standardization.

International Standards are drafted in accordance with the rules given in the ISO/IEC Directives, Part 2.

The main task of technical committees is to prepare International Standards. Draft International Standards adopted by the technical committees are circulated to the member bodies for voting. Publication as an International Standard requires approval by at least 75 % of the member bodies casting a vote.

Attention is drawn to the possibility that some of the elements of this document may be the subject of patent rights. ISO shall not be held responsible for identifying any or all such patent rights.

ISO 8308 was prepared by Technical Committee ISO/TC 45, *Rubber and rubber products*, Subcommittee SC 1, *Hoses (rubber and plastics)*.

This third edition cancels and replaces the second edition (ISO 8308:1993), which has been technically revised, the main changes being made in the procedure for method B.

iTeh STANDARD PREVIEW
(standards.iteh.ai)
ISO 8308:2006
<https://standards.iteh.ai/catalog/standards/sist/aea78083-9965-416e-8077-8395a21e007c/iso-8308-2006>

Rubber and plastics hoses and tubing — Determination of transmission of liquids through hose and tubing walls

1 Scope

This International Standard specifies two methods for the determination of transmission of liquids through hose and tubing walls. Both methods are applicable to rubber and plastics hose and tubing, and comprise:

- method A, for all hose sizes and constructions: a practical comparative test, simulating working conditions;
- method B, for hose and tubing up to 16 mm internal diameter.

2 Normative references

The following referenced documents are indispensable for the application of this document. For dated references, only the edition cited applies. For undated references, the latest edition of the referenced document (including any amendments) applies.

ISO 4671, *Rubber and plastics hoses and hose assemblies — Methods of measurement of dimensions of hoses and length of hose assemblies*

ISO 4788, *Laboratory glassware — Graduated measuring cylinders*

ISO 23529, *Rubber — General procedures for preparing and conditioning test pieces for physical test methods*

3 Principle

3.1 Method A

This method is carried out on an assembly mounted in a test apparatus fitted with equipment to fill and measure a charged volume of a volatile liquid. The system is put under pressure, and the change in volume measured at 24 h intervals until the change has become constant with time, i.e. an equilibrium state has been reached. The test result is this steady-state evaporation rate, expressed as the volume of liquid lost per hour per unit inside surface area of the hose or tubing.

3.2 Method B

This method uses a pressureless reservoir. A length of hose or tubing is attached to the reservoir, the other end of the hose or tubing being plugged. The reservoir is partially filled with test liquid and sealed. The assembly is weighed at the start of the test, and once every 24 h for eight days. The test result is the maximum mass of liquid lost in any one 24 h period per unit inside surface area of the hose or tubing.

NOTE The method accounts for loss by permeation and evaporation and helps to minimize selective permeation of components in a fuel mixture since the liquid is agitated daily.

4 Test liquid

The test liquid shall be that specified in the appropriate product standard.

5 Method A

WARNING — Because of the presence of potentially hazardous vapours, ensure that this test is carried out in a well-ventilated area.

5.1 Apparatus

The apparatus consists of a nitrogen gas source connected to a pipe system. The gas pressure is controlled by a regulator and pressure gauge.

It is essential that the system be provided with a safety valve.

The test piece is fixed vertically and is connected to the apparatus at the top via a measuring cylinder conforming to ISO 4788 and at the bottom via a charging valve (see Figure 1).

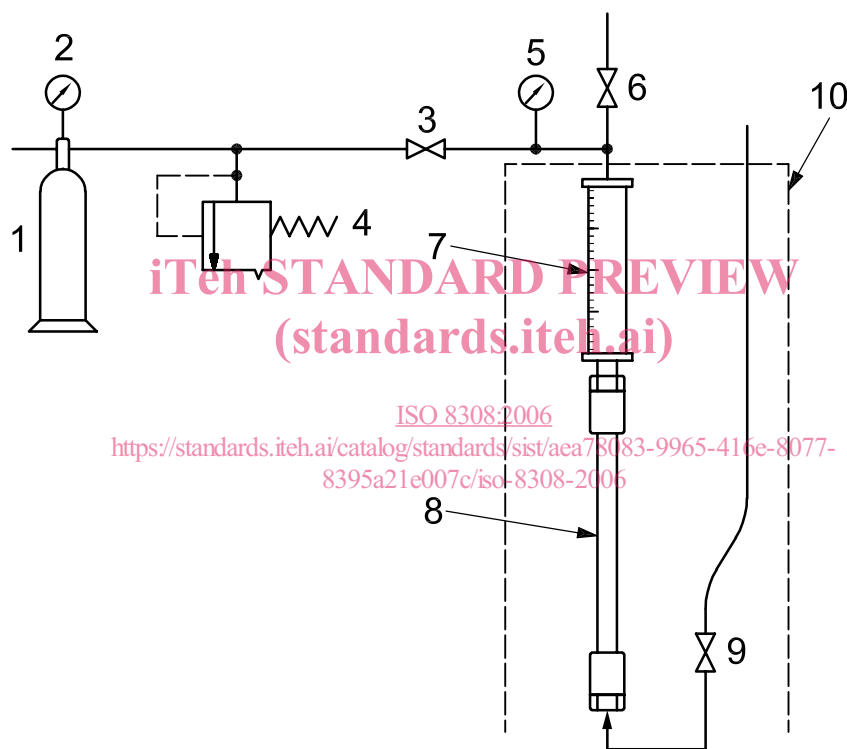

Key

- 1 pressurized-nitrogen source
- 2 pressure regulator
- 3 main valve
- 4 safety valve
- 5 pressure gauge
- 6 venting valve
- 7 measuring cylinder
- 8 test piece
- 9 charging valve
- 10 safety shield

Figure 1 — Apparatus for method A

5.2 Test pieces

Each test piece shall be either a hose assembly with a free hose length of 250 mm, or a sample of tubing, in accordance with Figure 2, fitted with suitable couplings and adapters.

Three test pieces shall be tested.

Dimensions in millimetres

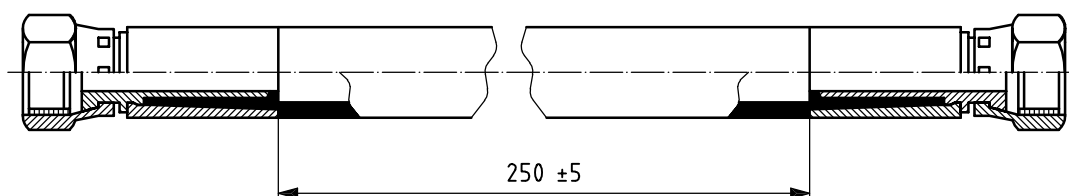

Figure 2 — Internal free length, with tolerance, of test piece

5.3 Test temperature

The test temperature shall be one of the standard temperatures defined in ISO 23529, i.e. either $(23 \pm 2)^\circ\text{C}$ or $(27 \pm 2)^\circ\text{C}$ in accordance with national practice.

(standards.iteh.ai)

5.4 Test pressure

The test pressure shall be $0,5 \text{ bar} \pm 0,05 \text{ bar}$ gauge pressure

ISO 8308:2006

<https://standards.iteh.ai/en/standards/cis/iso-8308-9965-416e-8077-8395a21e007c/iso-8308-2006>

5.5 Procedure

5.5.1 Determine the internal free length l , as indicated in Figure 2, and the internal diameter d , as specified in ISO 4671.

5.5.2 Connect the test piece to the test apparatus (see Figure 1).

5.5.3 Fill the test piece and the measuring cylinder with test liquid up to the top graduation mark of the measuring cylinder.

5.5.4 Maintain the test piece at the test pressure for 5 min, compensating for the dilation of the hose or tubing at the test pressure. Release the pressure and allow the dissolved nitrogen to escape over a period of 5 min, then record the initial reading V_1 shown by the measuring cylinder.

5.5.5 Apply the test pressure.

5.5.6 Take measurements after 24 h, 48 h, 72 h and 96 h, using the following method:

Close the main valve, then release the test pressure and wait 5 min before recording the new reading of V_1 . Close the venting valve, and then open the main valve to re-apply the test pressure.

If, after 96 h, the loss in volume per 24 h interval has not stabilized, take another measurement after 120 h (and another after 144 h if necessary).

5.6 Expression of results

5.6.1 Calculate the loss in volume for each 24 h interval between measurements, and determine the point at which the loss becomes constant. Beyond this point, diffusion of the liquid into the hose or tubing wall no longer contributes to the loss in volume, and the loss observed thus represents evaporation only.

5.6.2 If the steady state is reached before 72 h, calculate the evaporation rate, in millilitres per square metre per hour, using the formula

$$\frac{(V_{72} - V_{96}) \times 10^6}{\pi \times d \times l \times 24}$$

where

V_{72} is the volume, in millilitres, after 72 h;

V_{96} is the volume, in millilitres, after 96 h;

d is the internal diameter, in millimetres, of the hose or tubing;

l is the internal free length, in millimetres, of the hose or tubing.

In cases where further measurements have been made after periods longer than 96 h, replace V_{72} and V_{96} in the above formula by the corresponding penultimate and final volume measurements.

iTeh STANDARD PREVIEW
(standards.iteh.ai)

5.7 Test report

The test report shall include the following information:

- a) a full description of the hose or tubing tested; [ISO 8308:2006](#)
- b) a reference to this International Standard; <https://standards.iteh.ai/catalog/standards/sist/aea78083-9965-416e-8077-8395a21e007c/iso-8308-2006>
- c) the test method (method A);
- d) the test liquid used;
- e) the steady-state evaporation rate, expressed as millilitres lost per square metre per hour;
- f) the test temperature used;
- g) the date of the test.

6 Method B

6.1 Apparatus

6.1.1 Reservoir unit, consisting of a half-litre can, with a metal-foil or fluoroelastomer-lined screw-on cap, and with a standard hose nipple soldered into the bottom of the can at the corner opposite the filling hole (see Figure 3).

6.1.2 Scales or balance, with a minimum capacity of 400 g and readable to 0,01 g.

6.1.3 Impermeable hose plug, of sufficient size to seal one end of the hose or tubing to a depth of 12,5 mm.

6.1.4 Standard hose clamps, of the correct size for the hose or tubing being tested.

6.2 Test piece

Cut hose and tubing to 300 mm length.

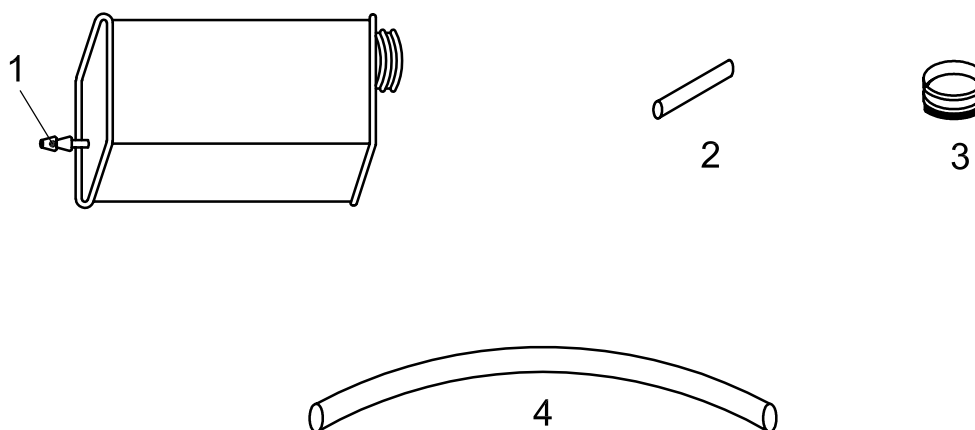

Key

- 1 standard hose nipple
- 2 hose plug
- 3 lined cap
- 4 hose or tubing

Figure 3 — Apparatus for method B

6.3 Test temperature

The test temperature shall be one of the standard temperatures defined in ISO 23529, i.e. either $(23 \pm 2) ^\circ\text{C}$ or $(27 \pm 2) ^\circ\text{C}$ in accordance with national practice.

<https://standards.iteh.ai/catalog/standards/sist/aea78083-9965-416e-8077-8395a21e007c/iso-8308-2006>

6.4 Procedure

<https://standards.iteh.ai/catalog/standards/sist/aea78083-9965-416e-8077-8395a21e007c/iso-8308-2006>

6.4.1 Gauge the hose or tubing bore and record the result in millimetres.

6.4.2 Plug one end of the test piece to a depth of 12,5 mm using an impermeable plug (6.1.3), as well as a hose clamp (6.1.4) if necessary.

6.4.3 Attach the other end of the test piece to the nipple on the reservoir (6.1.1) to a depth of 12,5 mm, using a hose clamp (6.1.4) if necessary.

6.4.4 Fill the reservoir with 300 ml of the specified test liquid.

It is important that the test piece remain filled with test liquid during the whole of the test, so that the whole of the inside surface remains in contact with the test liquid. If necessary, therefore, add more liquid during the test.

6.4.5 Seal the reservoir with the screw cap (see 6.1.1).

6.4.6 Weigh the reservoir/test piece assembly to the nearest 0,01 g and record the result.

6.4.7 To ensure complete filling of the hose, orient the assembly vertically and gently tap the hose to eliminate any air trapped in the hose (see Figure 4).

6.4.8 Place the assembly horizontally in its storage position with the reservoir resting on the narrow side nearest the nipple, and with the hose in a horizontal position (see Figure 5). The storage location shall be temperature-controlled to standard temperature (see 6.3), with free-flowing air to prevent fume build-up.

6.4.9 Weigh the assembly every $24 \text{ h} \pm 0,5 \text{ h}$ for eight days, recording each mass reading. If weekend weighings are to be eliminated and the results averaged for the weekends, then the test shall be started on a Monday.