



SLOVENSKI STANDARD
kSIST FprEN 16723-2:2017
01-marec-2017

Zemeljski plin in biometan za uporabo v prometu in biometan za dodajanje v omrežje zemeljskega plina - 2. del: Specifikacije goriv za motorna vozila

Natural gas and biomethane for use in transport and biomethane for injection in the natural gas network - Part 2: Automotive fuels

Erdgas und Biomethan zur Verwendung im Transportwesen und Biomethan zur Einspeisung ins Erdgasnetz - Teil 2: Festlegungen für Kraftstoffe für Kraftfahrzeuge

Gaz naturel et biométhane pour utilisation dans le transport et biométhane pour injection dans les réseaux de gaz naturel - Partie 2: Spécifications du carburant pour véhicules automobiles

Ta slovenski standard je istoveten z: FprEN 16723-2

ICS:

43.060.40	Sistemi za gorivo	Fuel systems
75.160.30	Plinska goriva	Gaseous fuels

kSIST FprEN 16723-2:2017 **en,fr,de**

EUROPEAN STANDARD
NORME EUROPÉENNE
EUROPÄISCHE NORM

FINAL DRAFT
FprEN 16723-2

January 2017

ICS 27.190; 75.160.30

English Version

Natural gas and biomethane for use in transport and biomethane for injection in the natural gas network - Part 2: Automotive fuels specification

Gaz naturel et biométhane pour utilisation dans le transport et biométhane pour injection dans les réseaux de gaz naturel - Partie 2: Spécifications du carburant pour véhicules automobiles

Erdgas und Biomethan zur Verwendung im Transportwesen und Biomethan zur Einspeisung ins Erdgasnetz - Teil 2: Festlegungen für Kraftstoffe für Kraftfahrzeuge

This draft European Standard is submitted to CEN members for formal vote. It has been drawn up by the Technical Committee CEN/TC 408.

If this draft becomes a European Standard, CEN members are bound to comply with the CEN/CENELEC Internal Regulations which stipulate the conditions for giving this European Standard the status of a national standard without any alteration.

This draft European Standard was established by CEN in three official versions (English, French, German). A version in any other language made by translation under the responsibility of a CEN member into its own language and notified to the CEN-CENELEC Management Centre has the same status as the official versions.

CEN members are the national standards bodies of Austria, Belgium, Bulgaria, Croatia, Cyprus, Czech Republic, Denmark, Estonia, Finland, Former Yugoslav Republic of Macedonia, France, Germany, Greece, Hungary, Iceland, Ireland, Italy, Latvia, Lithuania, Luxembourg, Malta, Netherlands, Norway, Poland, Portugal, Romania, Serbia, Slovakia, Slovenia, Spain, Sweden, Switzerland, Turkey and United Kingdom.

Recipients of this draft are invited to submit, with their comments, notification of any relevant patent rights of which they are aware and to provide supporting documentation.

Warning : This document is not a European Standard. It is distributed for review and comments. It is subject to change without notice and shall not be referred to as a European Standard.



EUROPEAN COMMITTEE FOR STANDARDIZATION
COMITÉ EUROPÉEN DE NORMALISATION
EUROPÄISCHES KOMITEE FÜR NORMUNG

CEN-CENELEC Management Centre: Avenue Marnix 17, B-1000 Brussels

Contents	Page
European foreword.....	3
Introduction	4
1 Scope.....	6
2 Normative references.....	6
3 Terms and definitions	6
4 Parameters and test methods.....	8
4.1 General.....	8
4.2 Standard reference conditions.....	8
4.3 Requirements, limit values and related test methods for natural gas and biomethane as automotive fuels.....	9
4.4 Requirement on climate-dependant characteristic and test methods for natural gas and biomethane as automotive fuels	10
5 Sampling.....	10
6 Marking, labelling and packaging	10
Annex A (informative) Parameters.....	11
A.1 Total silicon.....	11
A.2 Hydrogen.....	11
A.3 Compressor oil and solid particulates.....	12
A.4 Water dew point	12
A.5 Hydrocarbon dew temperature	13
A.6 Hydrogen sulfide plus Carbonyl sulfide.....	13
Annex B (informative) Odorization and sulfur.....	14
B.1 CEN/TC 408 approach	14
B.2 General.....	14
B.3 Total sulfur from Odorants.....	14
Annex C (informative) Properties of gases at the extremities of the Wobbe index ranges of the gas groups for gases of the second family.....	15
C.1 Introduction	15
C.2 Basis of calculations of indicative ranges.....	16
C.3 Calculated properties	17
C.4 Conclusions	17
Annex D (informative) Voluntary dedicated grades.....	20
Bibliography.....	22

European foreword

This document (FprEN 16723-2:2017) has been prepared by Technical Committee CEN/TC 408 “Natural gas and biomethane for use in transport and biomethane for injection in the natural gas grid”, the secretariat of which is held by AFNOR.

This document is currently submitted to the Formal Vote.

This document has been prepared under a mandate given to CEN by the European Commission and the European Free Trade Association.

EN 16723 consists of the following parts, under the general title “Natural gas and biomethane for use in transport and biomethane for injection in the natural gas network”:

- *Part 1: Specifications for biomethane for injection in the natural gas network*
- *Part 2: Automotive fuel specifications*

Introduction

This European Standard was prepared by CEN/TC 408 in response to the European Commission standardization mandate M/475.

The mandate asks for the development of a set of quality specifications for biomethane to be used as a fuel for vehicle engines and to be injected in natural gas pipelines (network).

However, the scope of the standard was widened according to BT decision C109/2012 that redefined the scope of CEN/TC 408: 'Standardization of specifications for natural gas and biomethane as vehicle fuel and of biomethane for injection in the natural gas grid, including any necessary related methods of analysis and testing. Production process, source and the origin of the source are excluded'.

NOTE 1 The CEN Technical Board (CEN/BT) is responsible for coordinating the work between technical bodies in order to achieve a coherent set of standards and to avoid overlaps.

NOTE 2 One of the aims of European policy in the field of energy is to increase the security of energy supply in the EU, as well as to contribute to reducing the emission of greenhouse gases accepted by the EU at Kyoto. In this context, special focus is given to the development and use of energy from renewable sources of biological and non-biological origin.

Figure 1 provides a visual representation of some applications of biomethane.

Mandate M/475 indicates that the requirements for natural gas quality for injection in the natural gas network are developed by CEN/TC 234 in answer to Mandate M/400 on natural gas quality. CEN/TC 408 should consider the work of the pending mandate M/400 on gas quality, and should refer to the parameters as defined and specified in EN 16726. This standard should exclude the definition of any parameters or substances that are addressed in EN 16726. However, it may specify more strict limits for parameters or substances unique to biomethane if deemed technically necessary. If needed, additional parameters or substances should be defined.

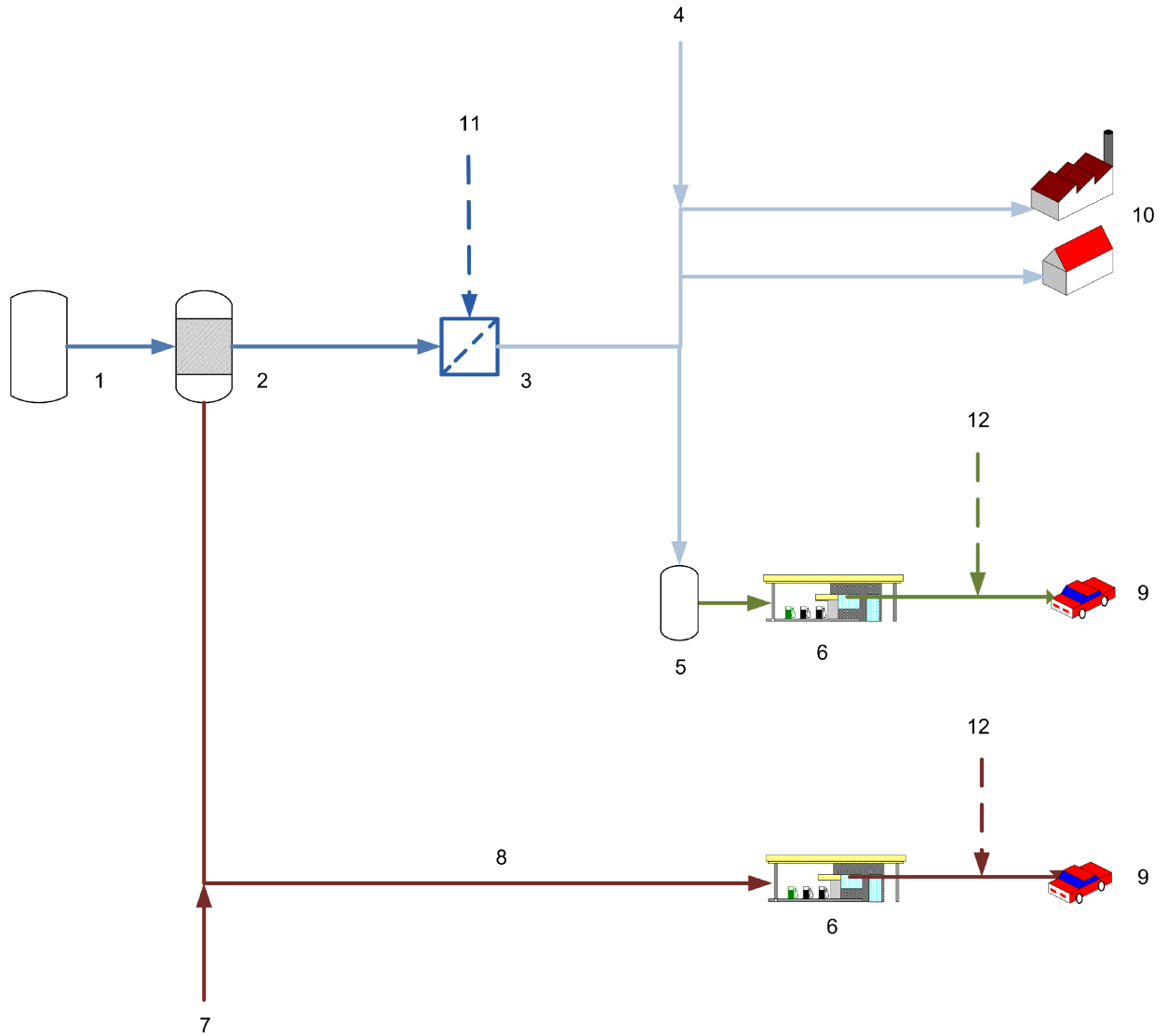

Key

- | | | | |
|---|---|----|----------------------------------|
| 1 | biogas from digestion or thermos chemical process | 7 | non-grid sourced natural gas |
| 2 | upgrading | 8 | local dedicated infrastructure |
| 3 | injection into the gas grid | 9 | automotive use |
| 4 | natural gas grid | 10 | domestic and industrial use |
| 5 | conditioning | 11 | Part 1: grid specification |
| 6 | refuelling station | 12 | Part 2: automotive specification |

Figure 1 — Representation of some flows and uses of biomethane and natural gas

FprEN 16723-2:2017 (E)

1 Scope

This European Standard specifies the requirements and test methods for natural gas (group L and H, as in EN 437), biomethane and blends of both at the point of use as automotive fuels.

This European Standard applies to the previously mentioned fuels irrespective of the storage state (compressed or liquefied).

To check compliance with some requirements set by the standard, LNG or liquefied biomethane should be re-gasified prior to testing.

2 Normative references

The following documents, in whole or in part, are normatively referenced in this document and are indispensable for its application. For dated references, only the edition cited applies. For undated references, the latest edition of the referenced document (including any amendments) applies.

EN 437, *Test gases - Test pressures - Appliance categories*

EN 16726:2015, *Gas infrastructure - Quality of gas - Group H*

EN 16942, *Fuels - Identification of vehicle compatibility - Graphical expression for consumer information*

EN ISO 10715, *Natural gas - Sampling guidelines (ISO 10715)*

EN ISO 13443, *Natural gas - Standard reference conditions (ISO 13443)*

3 Terms and definitions

For the purposes of this document, the terms and definitions given in EN 16726 as well as the following apply.

3.1 biogas

gas, comprising principally methane and carbon dioxide, obtained from the anaerobic digestion of biomass

3.2 biomass

biological material from living, or recently living organisms, typically this may be plants or plant-derived materials

3.3 biomethane

gas comprising principally methane, obtained from either upgrading of biogas or methanation of bio-syngas

3.4 bio-syngas

gas, comprising principally carbon monoxide and hydrogen, obtained from gasification of biomass

3.5 compressed natural gas CNG

natural gas used as a fuel for vehicles, typically compressed up to 20 000 kPa in the gaseous state