**Connections for hydraulic fluid power
and general use — Hose fittings —**

**Part 6:
Hose fittings with ISO 8434-6 60° cone
ends**

iTeh STANDARD PREVIEW
(standards.iteh.ai)

*Raccordements pour transmissions hydrauliques et applications
générales — Flexibles de raccordement —*

*Partie 6. Flexibles avec embouts à cône à 60° conformes
à l'ISO 8434-6*

ISO 12151-6:2009

<https://standards.iteh.ai/catalog/standards/sist/0b45dfc5-d61e-4e53-bbab-a6ca2cbc8254/iso-12151-6-2009>



PDF disclaimer

This PDF file may contain embedded typefaces. In accordance with Adobe's licensing policy, this file may be printed or viewed but shall not be edited unless the typefaces which are embedded are licensed to and installed on the computer performing the editing. In downloading this file, parties accept therein the responsibility of not infringing Adobe's licensing policy. The ISO Central Secretariat accepts no liability in this area.

Adobe is a trademark of Adobe Systems Incorporated.

Details of the software products used to create this PDF file can be found in the General Info relative to the file; the PDF-creation parameters were optimized for printing. Every care has been taken to ensure that the file is suitable for use by ISO member bodies. In the unlikely event that a problem relating to it is found, please inform the Central Secretariat at the address given below.

iTeh STANDARD PREVIEW
(standards.iteh.ai)

[ISO 12151-6:2009](https://standards.iteh.ai/catalog/standards/sist/0b45dfc5-d61e-4e53-bbab-a6ca2cbc8254/iso-12151-6-2009)

<https://standards.iteh.ai/catalog/standards/sist/0b45dfc5-d61e-4e53-bbab-a6ca2cbc8254/iso-12151-6-2009>



COPYRIGHT PROTECTED DOCUMENT

© ISO 2009

All rights reserved. Unless otherwise specified, no part of this publication may be reproduced or utilized in any form or by any means, electronic or mechanical, including photocopying and microfilm, without permission in writing from either ISO at the address below or ISO's member body in the country of the requester.

ISO copyright office
Case postale 56 • CH-1211 Geneva 20
Tel. + 41 22 749 01 11
Fax + 41 22 749 09 47
E-mail copyright@iso.org
Web www.iso.org

Published in Switzerland

Contents

Page

Foreword.....	iv
Introduction	v
1 Scope	1
2 Normative references	1
3 Terms and definitions	2
4 Performance requirements	2
5 Designation of hose fittings	2
6 Design	3
7 Manufacture.....	3
8 Assembly instructions	4
9 Procurement information.....	5
10 Marking	5
11 Identification statement (reference to this part of ISO 12151)	5
Bibliography	12

iTech STANDARD PREVIEW
(standards.iteh.ai)

ISO 12151-6:2009
<https://standards.iteh.ai/catalog/standards/sist/0b45dfc5-d61e-4e53-bbab-a6ca2cbc8254/iso-12151-6-2009>

Foreword

ISO (the International Organization for Standardization) is a worldwide federation of national standards bodies (ISO member bodies). The work of preparing International Standards is normally carried out through ISO technical committees. Each member body interested in a subject for which a technical committee has been established has the right to be represented on that committee. International organizations, governmental and non-governmental, in liaison with ISO, also take part in the work. ISO collaborates closely with the International Electrotechnical Commission (IEC) on all matters of electrotechnical standardization.

International Standards are drafted in accordance with the rules given in the ISO/IEC Directives, Part 2.

The main task of technical committees is to prepare International Standards. Draft International Standards adopted by the technical committees are circulated to the member bodies for voting. Publication as an International Standard requires approval by at least 75 % of the member bodies casting a vote.

Attention is drawn to the possibility that some of the elements of this document may be the subject of patent rights. ISO shall not be held responsible for identifying any or all such patent rights.

ISO 12151-6 was prepared by Technical Committee ISO/TC 131, *Fluid power systems*, Subcommittee SC 4, *Connectors and similar products and components*.

ISO 12151 consists of the following parts, under the general title *Connections for hydraulic fluid power and general use — Hose fittings*:

- Part 1: *Hose fittings with ISO 8434-3 O-ring face seal ends*
- Part 2: *Hose fittings with ISO 8434-1 and ISO 8434-4 24° cone connector ends with O-rings*
- Part 3: *Hose fittings with ISO 6162-1 or ISO 6162-2 flange ends*
- Part 4: *Hose fittings with ISO 6149 metric stud ends*
- Part 5: *Hose fittings with ISO 8434-2 37° flared ends*
- Part 6: *Hose fittings with ISO 8434-6 60° cone ends*

Introduction

In hydraulic fluid power systems, power is transmitted and controlled through a liquid under pressure within an enclosed circuit. In general applications, the fluid may be conveyed under pressure.

Components are connected through their ports by stud ends on fluid conductor connectors to tubes or pipes or to hose fittings and hoses.

ISO/TC 131/SC 4 recommends that hose fittings that conform to ISO 12151-1 and ISO 12151-2 be used because these International Standards represent the state of the art. However, this part of ISO 12151 has been developed because it specifies hose fittings that are currently used worldwide.

iTeh STANDARD PREVIEW (standards.iteh.ai)

[ISO 12151-6:2009](https://standards.iteh.ai/catalog/standards/sist/0b45dfc5-d61e-4e53-bbab-a6ca2cbc8254/iso-12151-6-2009)

<https://standards.iteh.ai/catalog/standards/sist/0b45dfc5-d61e-4e53-bbab-a6ca2cbc8254/iso-12151-6-2009>

iTeh STANDARD PREVIEW
(standards.iteh.ai)

ISO 12151-6:2009

<https://standards.iteh.ai/catalog/standards/sist/0b45dfc5-d61e-4e53-bbab-a6ca2cbc8254/iso-12151-6-2009>

Connections for hydraulic fluid power and general use — Hose fittings —

Part 6: Hose fittings with ISO 8434-6 60° cone ends

1 Scope

This part of ISO 12151 specifies the general and dimensional requirements for the design and performance of hose fittings made of carbon steel with 60° cone ends for hose sizes 5 to 51 inclusive, in accordance with ISO 4397.

These hose fittings (see Figure 1 for a typical example) are for use in hydraulic fluid power systems with hoses that meet the requirements of the respective hose standards and in general applications with suitable hoses.

NOTE 1 Other materials can be supplied as agreed between the manufacturer and user.

NOTE 2 For hose fittings used in hydraulic and pneumatic braking systems on road vehicles (as defined in the scope of ISO/TC 22), see ISO 4038, ISO 4039-1 and ISO 4039-2.

2 Normative references

The following referenced documents are indispensable for the application of this document. For dated references, only the edition cited applies. For undated references, the latest edition of the referenced document (including any amendments) applies.

ISO 228-1, *Pipe threads where pressure-tight joints are not made on the threads — Part 1: Dimensions, tolerances and designation*

ISO 4397, *Fluid power systems and components — Connectors and associated components — Nominal outside diameters of tubes and nominal sizes of hoses*¹⁾

ISO 4759-1, *Tolerances for fasteners — Part 1: Bolts, screws, studs and nuts — Product grades A, B and C*

ISO 5598, *Fluid power systems and components — Vocabulary*

ISO 6605, *Hydraulic fluid power — Hoses and hose assemblies — Test methods*

ISO 8434-6, *Metallic tube connections for fluid power and general use — Part 6: 60° cone connectors with or without O-ring*²⁾

ISO 9227, *Corrosion tests in artificial atmospheres — Salt spray tests*

ISO 19879, *Metallic tube connections for fluid power and general use — Test methods for hydraulic fluid power connections*

1) Under development. (Revision of ISO 4397:1993)

2) To be published.

3 Terms and definitions

For the purposes of this part of ISO 12151, the terms and definitions given in ISO 5598 shall apply.

4 Performance requirements

Hose assemblies shall meet the performance requirements specified in the appropriate hose specification without leakage or failure when tested in accordance with ISO 6605.

The rated (working) pressure of the hose assembly shall be the lower of the rated pressure given for its size in ISO 8434-6 and the working pressure in the relevant hose specification.

The rated pressure of the hose fitting shall be verified through testing conducted in accordance with ISO 19879, but the entire hose assembly shall be tested in accordance with ISO 6605. During the cyclic endurance test, the hose assembly shall be subjected to the number of cycles specified in the relevant hose specification.

5 Designation of hose fittings

5.1 Hose fittings shall be designated by an alphanumeric code to facilitate ordering. They shall be designated by the phrase "Hose fitting," followed by "ISO 12151-6", followed by a spaced hyphen, then the connection end type, shape and sealing style letter symbols (see 5.4), followed by another spaced hyphen, the 60° cone connector end size (nominal tube outside diameter in accordance with ISO 8434-6) and the hose size (nominal hose inside diameter in accordance with ISO 4397), each separated by a multiplication symbol (×).

EXAMPLE A swivel hose fitting O-ring sealing with 45° elbow, for 12 mm nominal OD tubing and 12,5 mm nominal ID hose, is designated as follows:

Hose fitting ISO 12151-6 - SWE45A - 12 × 12,5

5.2 The letter symbol designation of the hose fitting shall consist of the connection end type, immediately followed by the shape of the fitting and the nut style, where applicable.

5.3 Tube ends are assumed to be male and thus do not need to be included in the code. However, if another end is involved, it shall be designated.

5.4 The following letter symbols shall be used:

Connection end type	Letter
Swivel	SW

Shape	Letter
Straight	S
90° elbow	E
45° elbow	E45

Sealing	Style
O-ring	A
Non O-ring	B

6 Design

6.1 Figure 1 shows a typical example of a hose fitting with a 60° cone connection end.

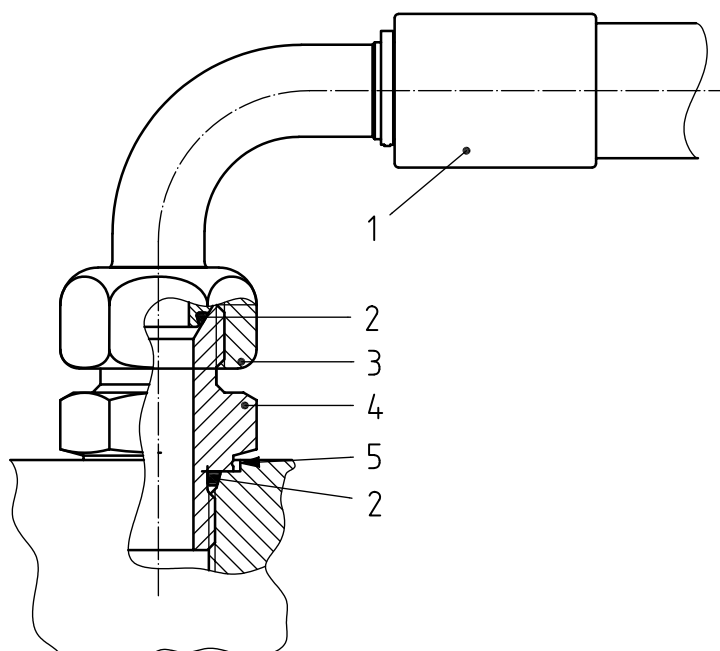

Key

- 1 hose fitting
- 2 O-ring seal
- 3 nut
- 4 straight stud connector conforming to ISO 8434-6
- 5 port conforming to ISO 6149-1

iTech STANDARD PREVIEW
(standards.iteh.ai)

<https://standards.iteh.ai/standards/sist/0b45dfc5-d61e-4e53-bbab-a6ca2cbc8254/iso-12151-6-2009>

Figure 1 — Typical example of hose fitting with 60° cone connection

6.2 Hose fitting dimensions shown in Figures 2 through 5 shall conform to the dimensions in Tables 1 through 4 and to the relevant dimensions in ISO 8434-6.

6.3 Hex tolerances across flats shall be in accordance with ISO 4759-1, product grade C. Minimum across-corner hex diameters are 1,092 times the nominal width across flats. The minimum side flat is 0,43 times the nominal width across flats.

6.4 Angular tolerances on axes of ends of elbows shall be $\pm 3^\circ$ for all sizes.

6.5 Details of contour shall be as chosen by the manufacturer, provided that the dimensions given in Tables 1 through 4 are maintained.

6.6 The screw threads on the connection ends of the hose fittings shall be inch screw threads in accordance with ISO 228-1.

7 Manufacture

7.1 Construction

Hose fittings may be forged, cold-formed, machined from barstock or manufactured from multiple components.

7.2 Workmanship

Workmanship shall conform to the best commercial practice to produce high-quality hose fittings. Hose fittings shall be free from visual contaminants, all hanging burrs, loose scale and slivers which can be dislodged in use and any other defects that might affect the function of the parts. All machined surfaces shall have a surface roughness value of Ra max 6,3 μm , except where otherwise specified.

7.3 Finish

The external surface and threads of all carbon steel parts shall be plated or coated with a suitable material that passes a 72 h neutral salt spray test in accordance with ISO 9227, unless otherwise agreed on by the manufacturer and the user. Any appearance of red rust during the salt spray test on any area, except those noted below, shall be considered a failure:

- all internal fluid passages;
- edges, such as hex points, serrations and crest of threads, where there may be mechanical deformation of the plating or coating typical of mass-produced parts or shipping effects;
- areas where there is a mechanical deformation of the plating or coating caused by crimping, flaring, bending and other post-plate metal forming operations;
- areas where the parts are suspended or affixed in the test chamber where condensate can accumulate.

Internal fluid passages shall be protected from corrosion during storage.

Cadmium plating is not allowed because of environmental concerns. Parts manufactured in accordance with this part of ISO 12151 shall not be cadmium-plated. Hexavalent chromate coatings are not preferred because of environmental concerns. Changes in plating may affect assembly torques and require requalification, when applicable.

<https://standards.iteh.ai/catalog/standards/sist/0b45dfc5-d61e-4e53-bbab-a6ca2cbc8254/iso-12151-6-2009>

7.4 Protection

By a method agreed upon between supplier and purchaser, the cone face of the hose fittings and threads (both internal and external) shall be protected by the manufacturer from nicks and scratches that can be detrimental to the function of the hose fitting. Passages shall be securely covered to prevent the entrance of dirt or other contaminants. Covers that contribute to contamination shall not be used.

Braze-on-type connectors require protection on the sealing face and threaded end only. Nuts and sleeves that are furnished separately from the connector shall be protected from rust but do not require capping.

8 Assembly instructions

The assembly of the hose fittings to other connectors or tubes shall be carried out without external loads. The manufacturer shall draw up assembly instructions for the use of hose fittings. These instructions shall include at least the following:

- instructions regarding the assembly of the hose fitting, such as number of wrenching turns or assembly torque;
- recommendations regarding the tools for use during assembly.

When hose fittings are used with tubes, follow the instructions related to material, preparation and attachment given in ISO 8434-6, as appropriate.

9 Procurement information

The following minimum information should be supplied by the purchaser when making an inquiry or placing an order:

- description of hose fitting (using the designation in accordance with Clause 5);
- material of hose fitting (if other than carbon steel);
- hose type and size;
- fluid being conveyed;
- rated pressure;
- working temperature (ambient and of the fluid).

10 Marking

Hose fittings shall be permanently marked with the manufacturer's name or trademark.

11 Identification statement (reference to this part of ISO 12151)

It is strongly recommended to manufacturers who have chosen to conform to this part of ISO 12151 that the following statement be used in test reports, catalogues and sales literature:

"Hose fittings with 60° cone ends in conformance with ISO 12151-6:2009, *Connections for hydraulic fluid power and general use — Hose fittings — Part 6: Hose fittings with ISO 8434-6 60° cone ends.*"