



## **Standard Test Method for Designation: E 1592 – 05 Structural Performance of Sheet Metal Roof and Siding Systems by Uniform Static Air Pressure Difference<sup>1</sup>**

This standard is issued under the fixed designation E 1592; the number immediately following the designation indicates the year of original adoption or, in the case of revision, the year of last revision. A number in parentheses indicates the year of last reapproval. A superscript epsilon ( $\epsilon$ ) indicates an editorial change since the last revision or reapproval.

### INTRODUCTION

Computations are the accepted method for determining the structural capacity of most metal products. However, some conditions are outside the scope of analysis by industry specifications.

Methods of computation and a discussion of these conditions are found in the following documents: AISI Specification for the Design of Cold-Formed Steel Structural Members and Load and Resistance Factor Specification for Cold-Formed Steel Structural Members and Aluminum Association Specifications for Aluminum Structures.

This test method is not to be considered as a wind design standard. It is a structural capacity test to determine the ability of a panel system (including attachments) to resist uniform static pressure. Actual wind pressure is nonuniform and dynamic. ~~When these~~ These uniform static test results ~~are~~ should be used in conjunction with commonly recognized wind design standards, ~~they~~ and will yield highly conservative results.

When additional fasteners are installed across panel flats at eaves, ridges, or reinforced end laps, the crosswise distortion is eliminated and *both flexural capacity and anchor-to-panel attachment strength can vary with the distance from such conditions*. This test procedure can be used to evaluate the strength of panels and attachments at any distance from end or edge perimeter conditions. The size of the specimen and limitations on air seals are designed to minimize any interference with the natural response of the panels under load.

### 1. Scope

1.1 This test method covers the evaluation of the structural performance of sheet metal panels and anchor-to-panel attachments for roof or siding systems under uniform static air pressure differences using a test chamber or support surface.

1.2 The provisions of this test method are applicable to standing seam, trapezoidal, ribbed, or corrugated metal panels in the range of thickness from 0.012 to 0.050-in. (0.3 to 1.3-mm) and apply to the evaluation of uniform pressure applied to single-skin construction or one sheet metal layer of multiple-skin construction. They do not cover requirements for the construction of a specimen to determine the load sharing that can occur with either composite or multiple-layer construction such as: (1) metal cladding over wood sheathing; or (2) field assemblies of insulation sandwiched between corrugated or formed metal panels.

1.3 Proper use of this test method requires knowledge of the principles of pressure and deflection measurement.

1.4 This test method describes optional apparatus and procedures for use in evaluating the structural performance of a given system for a range of support spacings or for confirming the structural performance of a specific installation.

1.5 The values stated in inch-pound units are to be regarded as the standard. The metric equivalents of inch-pound units are approximate.

1-6

1.6 The text of this standard references notes and footnotes exclusive of those for tables and figures. These notes and footnotes provide explanatory material and shall not be considered as requirements of the standard.

1.7 This standard does not purport to address all of the safety concerns, if any, associated with its use. It is the responsibility of the user of this standard to establish appropriate safety and health practices and determine the applicability of regulatory limitations prior to use. For specific precautionary statements, see Section 7.

~~1.7 The text of this standard references notes and footnotes exclusive of those for tables and figures. These notes and footnotes~~

<sup>1</sup> This test method is under the jurisdiction of ASTM Committee E06 on Performance of Buildings and is the direct responsibility of Subcommittee E06.57 on Performance of Metal Roofing Systems.

Current edition approved April 10, 2001. Published July 2001. Originally published as E1592-95. Last previous edition E 1592-98.

Current edition approved June 1, 2005. Published June 2005. Originally approved in 1995. Last previous edition approved in 2001 as E 1592 – 01.

provide explanatory material and shall not be considered as requirements of the standard.

## 2. Referenced Documents

### 2.1 ASTM Standards:<sup>2</sup>

A 370 [Test Methods and Definitions for Mechanical Testing of Steel Products](#)

B 557 [Test Methods for Tension Testing Wrought and Cast Aluminum- and Magnesium-Alloy Products](#)

### 2.2 Aluminum Association Standard:<sup>3</sup>

Aluminum Formed-Sheet Building Sheathing Design Guide, Appendix B of *Specifications for Aluminum Structures*, Latest Edition

### 2.3 AISI Standards:<sup>4</sup>

Specification for the Design of Cold-Formed Steel Structural Members, Latest Edition

### 2.4 Other Documents:

ASCE7 (Formerly ANSI A58.1) Minimum Design Loads for Buildings and Other Structures<sup>5</sup>

## 3. Terminology

### 3.1 Descriptions of Terms Specific to This Standard:

3.1.1 *anchor*, *n*—a fastener, bolt, screw, or formed device such as a clip that connects panels to the support structure.

3.1.2 *anchor failure*, *n*—any failure at the anchor device, including separation of the device from the panel, of the device itself, or of the connection to the structural support.

3.1.3 *crosswise restraint*, *n*—any attachment in the flat of a panel between structural elements that controls or limits pan distortion under pressure.

3.1.4 *failure*, *n*—fracture or disengagement of any of the components where the system is no longer capable of sustaining load, or the system no longer functions as a weathertight membrane.

3.1.5 *interior support*, *n*—any support other than those at either extreme in a series of supports for a continuous panel.

3.1.6 *pan distortion*, *n*—displacement under load of normally flat portions of a panel profile normal to the plane of the roof or wall surface.

3.1.7 *panel deflection*, *n*—displacement under load measured normal to the plane of the roof or wall surface of a longitudinal structural element as measured from a straight line between structural supports.

3.1.8 *permanent deformation*, *n*—the permanent displacement in any direction from an original position that remains after an applied load has been removed.<sup>6</sup>

3.1.9 *reference zero load*, *n*—nominal pressure applied to a specimen to provide a reference position free of variations from internal stresses or friction within the system assembly.

3.1.10 *rib spread*, *n*—panel distortion under load at the base of a rib or standing seam as measured crosswise to the rib in the plane of the roof or wall surface.

3.1.11 *span length*, *n*—the center-to-center distance between anchors or supports measured parallel to the longitudinal axis of the panel.

3.1.12 *specimen*, *n*—the entire assembled unit submitted for testing, as described in Section 8.

3.1.13 *specimen length*, *n*—the distance from center to center of the end supports; the sum of individual span lengths.

3.1.14 *structural element*, *n*—the width of a panel profile as measured between center lines of repeating longitudinal stiffeners for continuously supported panels in a positive load test or the width between anchor attachments to repeating stiffener elements in a negative load test.

3.1.15 *test load*, *n*—the difference in static air pressure (positive or negative) between the inside and outside face of the specimen, expressed in pounds-force per square foot (lbf/ft<sup>2</sup>) or pascals (Pa).

3.1.16 *test panel length*, *n*—specimen length plus overhangs.

3.1.17 *ultimate load*, *n*—the difference in static air pressure (positive or negative) at which failure of the specimen occurs, expressed in pounds-force per square foot (lbf/ft<sup>2</sup>) or pascals (Pa).

3.1.18 *unlatching failure*, *n*—disengagement of a panel seam or anchor that occurs in an unloaded assembly due to permanent

<sup>2</sup> Annual Book of ASTM Standards, Vol 01.05.

<sup>2</sup> For referenced ASTM standards, visit the ASTM website, [www.astm.org](http://www.astm.org), or contact ASTM Customer Service at [service@astm.org](mailto:service@astm.org). For *Annual Book of ASTM Standards* volume information, refer to the standard's Document Summary page on the ASTM website.

<sup>3</sup> Annual Book of ASTM Standards, Vol 02.02.

<sup>3</sup> Available from Aluminum Association, 900 19th Street, NW, Washington, DC 20006.

<sup>4</sup> Available from Aluminum Association, 900 19th Street, NW, Washington, DC 20006.

<sup>4</sup> Available from American Iron and Steel Institute (AISI), 1140 Connecticut Ave., Suite 705, Washington, DC 20036.

<sup>5</sup> Available from American Iron and Steel Institute, 1101 17th Street NW, Suite 1300 Washington, DC 20036-4700.

<sup>5</sup> Available from The American Society of Civil Engineers (ASCE), 1801 Alexander Bell Dr., Reston, VA 20191.

<sup>6</sup> Available from American Society of Civil Engineers, 345 East 47th Street, New York, NY 10017-2398.

<sup>6</sup> Industry design procedures propose different factors of safety on yield and ultimate strength. Not all permanent distortion is harmful to the structural performance of the system. Only permanent distortion that interferes with the performance of the system is significant.

set or distortion that occurred under a previous load condition.<sup>7</sup>

3.1.19 *yield load, n*—that pressure at which deflection increases are no longer proportional to the increase in pressure. Yielding is not failure.<sup>8</sup>

3.1.20 *zero load, n*—the absence of air pressure difference across the specimen.

#### 4. Summary of Test Method

4.1 This test method consists of the following: (1) sealing the test specimen into or against one face of a test chamber; (2) supplying air to, or exhausting air from, the chamber at the rate required to maintain the test pressure difference across the specimen; and (3) observing, measuring, and recording the deflection, deformations, and nature of any failures of principal or critical elements of the panel profile or members of the anchor system.

4.2 The increments of load application shall be chosen such that a sufficient number of readings will be obtained to determine the load deformation curve of the system.

4.3 End and edge restraint shall be representative of field conditions, and the unit shall contain sufficient individual components to minimize the effect of variations in material and workmanship.

#### 5. Significance and Use

5.1 This test method provides a standard procedure to evaluate or confirm structural performance under uniform static air pressure difference. This procedure is intended to represent the effects of uniform loads on exterior building surface elements.

5.2 It is also permissible to develop data for load-span tables by interpolating between the test results at different spans.

NOTE 1—When applying the results of tests to determine allowable design loads by application of a factor of safety, bear in mind that the performance of a wall or roof and its components, or both, can be a function of fabrication, installation, and adjustment. The specimen must represent the actual structure closely. In service, the performance can also depend on the rigidity of supporting construction and on the resistance of components to deterioration by various causes, to vibration, to thermal expansion and contraction, etc.—and so forth.

#### 6. Apparatus

6.1 The description of apparatus is general in nature; any equipment capable of performing the test procedure within the allowable tolerances is permitted. Major components are shown in Fig. 1.

6.2 *Test Chamber*—A test chamber, air bag, or box with an opening, a removable mounting panel, or one open surface in which or against which the specimen is installed. Provide at least two static pressure taps located at diagonally opposite corners to measure the chamber pressure such that the reading is unaffected by the velocity of the air supply to or from the chamber or any other air movement. The air supply opening into the chamber shall be arranged so that the air does not impinge directly on the test specimen with any significant velocity. A means of access into the chamber to facilitate adjustments and observations after the specimen has been installed is optional.

NOTE 2—The test chamber or the specimen mounting frame, or both, must not deflect under the test load in such a manner that the performance of the specimen will be affected. In general, select anchor support members sufficiently rigid that deflection under the test load will be negligible. It is desirable to be able to observe the fit of the plastic film against the specimen as well as the metal surface. When the specimen is tested with plastic film on either side, it is recommended that windows, lighting, or other methods be used to allow observation of the opposite side.

6.3 *Air System*—A compressed air supply, an exhaust system, or controllable blower is to be provided to develop the required air pressure difference across the specimen. The system shall maintain an essentially constant air pressure difference for the required test period.

NOTE 3—It is convenient to use a reversible blower or separate pressure and exhaust systems to provide the required air pressure difference so that different test specimens can be tested for the effect of positive pressure or the effect of suction (negative pressure) without reversing the position of the test specimen. The use of the same specimen for both positive and negative testing is outside the scope of this test method. If an adequate air supply is available, a completely airtight seal need not be provided around the perimeter of the test specimen and the mounting panel, although it is preferable. However, substantial air leakage will require an air supply of much greater capacity to maintain the required pressure differences.

6.4 *Pressure-Measuring Apparatus* —The devices to measure the test pressure difference shall operate within a tolerance of  $\pm 2\%$  of the design pressure, or within 0.1 in. (2.5 mm) of water pressure (0.52 psf or 25 Pa) and be located as described in 6.1.

6.5 *Deflection and Distortion Measurement Precision:*

6.5.1 The means of measuring deflections of structural ribs between the reaction supports and movement of the ribs at the supports shall provide readings within a tolerance of  $\pm 0.01$  in. (0.25 mm).

<sup>7</sup> Industry design procedures propose different factors of safety on yield and ultimate strength. Not all permanent distortion is harmful to the structural performance of the system. Only permanent distortion that interferes with the performance of the system is significant. The roof must still be capable of acting as a weather-tight membrane.

<sup>7</sup> This permanent set is not always detectable from readings taken normal to the panel.

<sup>8</sup> This permanent set is not always detectable from readings taken normal to the panel.

<sup>8</sup> It is often impractical to take direct measurements on individual elements in an assembly of components. Readings made on a panel surface opposite an anchor clip include deflection of non-axial loads in the anchor base and panel profile as well as any slippage that occurs in the panel connection or between segments of a multiple-piece clip. They may decrease with increasing pressure and produce a bi-linear curve. Subsequent small-scale tests may be required to determine whether nonlinear deflection readings represent tolerable distortions that do not interfere with long-term anchor performance.

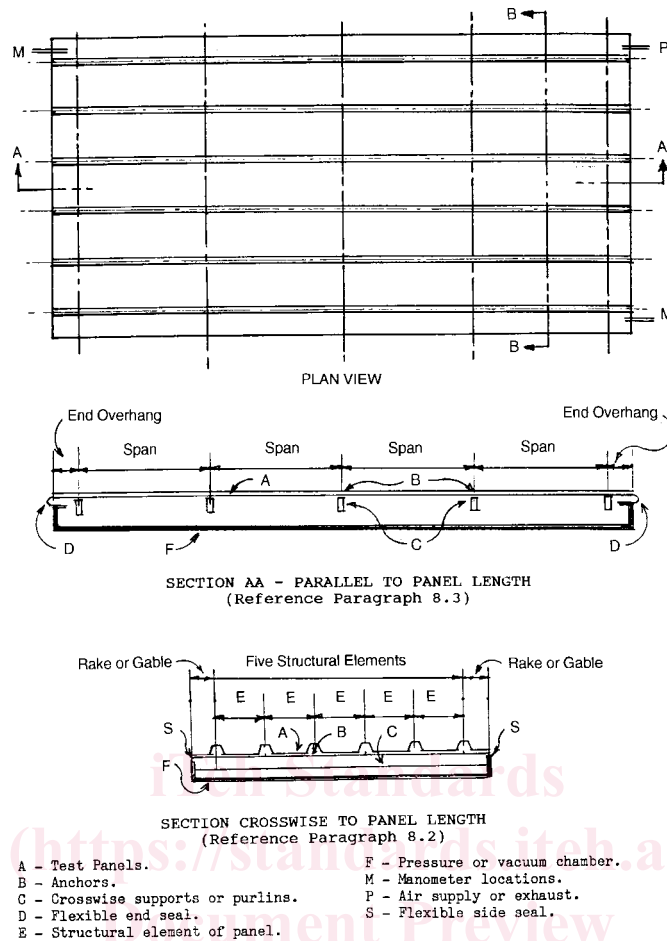

FIG. 1 Schematic of Test Apparatus

6.5.2 The means of measuring pan distortion shall provide readings within a tolerance of  $\pm 1/16$  in. (1.5 mm).

6.5.3 The means of measuring rib spread, when required, shall provide readings within a tolerance of  $\pm 1/16$  in. (1.5 mm).

6.6 Reading Locations:

6.6.1 Support deflection gages or measuring devices so that readings are not influenced by movements of, or within, the specimen or member supports.

6.6.2 Measure the maximum mid-span and span end (at anchor support) deflections of at least one structural rib not influenced by the attachment or seal to the test chamber. Additional locations for deflection measurements, if desired, shall be stated by the specifier of the test.

6.6.3 Measure pan distortion in the middle of at least one panel flat (between structural elements) at a minimum of three locations.

6.6.4 Rib spread readings are optional for measuring panel distortion.

6.7 Reading Frequency:

6.7.1 In all cases readings shall be taken at initial zero or preload, at each increment of load, and again at the zero or preload to determine permanent set. See 10.2.4 regarding the selection of zero load.

7. Safety Precautions

7.1 Take proper precautions to protect the operating personnel and observers in the event of any failure.<sup>9</sup>

8. Test Specimen

8.1 The test specimens shall be of sufficient size to determine the performance of all typical parts of the system. Conditions of

<sup>9</sup> It is often impractical to take direct measurements on individual elements in an assembly of components. Readings made on a panel surface opposite an anchor clip include deflection of non-axial loads in the anchor base and panel profile as well as any slippage that occurs in the panel connection or between segments of a multiple-piece clip. They may decrease with increasing pressure and produce a bi-linear curve. Subsequent small-scale tests may be required to determine whether nonlinear deflection readings represent tolerable distortions that do not interfere with long-term anchor performance.

<sup>9</sup> At the pressures used in this test method, considerable energy and hazard are involved. In cases of failure, the hazard to personnel is less with an exhaust system, as the specimen will tend to blow into the test chamber rather than out. Do not permit personnel in such chambers during the application of a pressure difference.

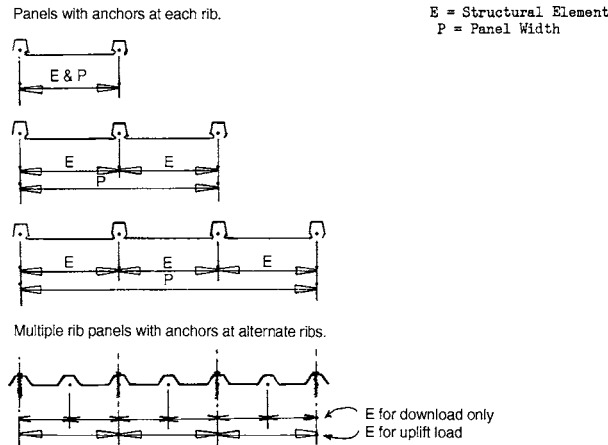

FIG. 2 Examples of Structural Elements and Panel Width for Different Profiles

TABLE 1 Minimum Number of Equal Spans To Comply With 8.3<sup>A</sup>

Ends with Crosswise Restraint	2	1
Span length	Number of equal spans	
12 ft–0 in. (3.7 m) or more	2	2
below 12 ft (3.7m) to 8 ft–0 in. (2.4 m)	3	2
below 8 ft (2.4 m) to 6 ft–0 in. (1.8 m)	4	3
below 6 ft (1.8 m) to 5 ft–0 in. (1.5 m)	5	3
below 5 ft (1.5 m) to 4 ft–0 in. (1.2 m)	24/L	3
below 4 ft (1.2 m) to 3 ft–0 in. (0.9 m)	24/L	4
below 3 ft (0.9 m) to 2 ft–0 in. (0.6 m)	24/L	5
below 2 ft (0.6 m)	24/L	1 + 8/L

<sup>A</sup> Count fractional spans as whole numbers, that is, 24/4.75 = 5.05, use 6 spans, where L is the span in feet.

structural support shall be simulated as accurately as possible, and the full length and width, including overhangs, shall be loaded. All parts of the test specimen shall be full size, using the same materials, details, and methods of construction and anchorage as used on the actual building. Except for positive load as in 8.2.2, any partial width sheets shall not be considered in figuring specimen width.

8.2 Specimen Width— Edge seals shall not contain structural attachments that restrict deflection of the test panel any more than the normal gable condition.

8.2.1 For the evaluation of either bending capacity or anchor to panel attachment strength under negative load, the specimen width shall contain not less than three full panels and five structural elements (see Fig. 2).

8.2.2 For the evaluation of panel bending capacity in resisting positive pressure, the specimen width shall be as specified in 8.2.1 or be not less than 40 % of the clear span and include not less than four structural elements with not less than one half the flat distance to the next adjacent nonincluded parallel rib, corrugation, or stiffener on each side.

8.3 Specimen Length— For negative (uplift) load tests (or any form of loading that tends to push panels away from the crosswise support), unless the test represents the full length used, the specimen length shall be sufficient to ensure that end seals or attachments do not restrict panel movement at the area under investigation.

8.3.1 For the evaluation of anchor to panel strength free of end influence, the arbitrary minimum specimen length, (exclusive of the end overhangs) when both ends have crosswise restraint, is 24 ft (7.3 m). Shorter lengths are acceptable when only one end has crosswise restraint and when the unrestrained end is a minimum of 8 ft (2.4 m) from at least one row of interior anchors. (see — For negative (uplift) load tests (or any form of loading that tends to push panels away from the crosswise support), unless the test represents the full length used, the specimen length shall be sufficient to ensure that end seals or attachments do not restrict panel movement at the area under investigation, as defined in Table 1).

8.3.2 For the evaluation of anchor to panel strength, the results are deemed to be free of end influence when measurements of panel distortion indicate that the sample is outside the effect of the end condition as follows:

8.3.2.1 When maximum mid-span panel distortion readings of an identical 24-ft (7.3-m) panel do not exceed (within the tolerance of the measurement) the maximum readings on the shorter setup; or

8.3.2.2 When maximum mid-span panel distortion readings do not exceed (within the tolerance of the measurement) the mid-span distortion readings at least 4 ft (1.2 m) on both sides of at least one purlin.

8.3.3 For positive load tests, where the panels are supported to resist the applied load at each structural element in the mid-roof



area as well as at the ends, the specimen length is not restricted.<sup>10</sup>

8.3.1 For positive load tests, where the panels are supported to resist the applied load at each structural element in the mid-roof area as well as at the ends, the specimen length is not restricted.

8.4 Structural supports used in the test shall be of sufficient strength and rigidity to minimize deflection of the assembly. For supports used in positive pressure tests, due consideration must be given to the width of the support that is in contact with the panel.<sup>11</sup>

8.5 End conditions that simulate eave or ridge flashing situations in which the panel terminates at or slightly beyond the purlin are considered to have crosswise restraint and influence distortion for some distance along the length of the panel. An open-end condition is one without crosswise restraint.

8.5.1 It is permissible to reinforce open-end conditions to prevent non-typical failures of clip to panel attachment or of web buckling caused by proximity of the free edge to the support. Acceptable reinforcement includes longitudinal stiffeners in the flats to prevent buckling of flats. Also acceptable are seam fasteners at the ends of ribs to prevent un-seaming from the free end. Seam reinforcers shall not be located more than 4 in. from the end of the test panel. The reinforcement shall not restrict crosswise panel deformation nor cause the end seal to pull away from the pan as panels distort under load.

8.5.1.1 The method of seam reinforcement must be validated by comparing the mid-span distortion nearest the open end of an open-closed specimen (consisting of the minimum number of spans allowed) with the mid-span pan distortion nearest to the longitudinal center of a closed-closed specimen (consisting of the minimum number of spans allowed), measured at the same pressure interval at which the open-closed specimen was measured. The closed-closed specimen must be identical to the open-closed specimen in panel configuration, material, gauge, panel, width, clip attachment, and span. The validation test must follow all procedures for a typical test, including load cycles. Measurements at the maximum pressure experienced just prior to the lower failure load of the two tests only need be considered.

8.5.1.2 If the magnitude of the mid-span pan distortion of the closed-closed specimen is equal to or exceeds the magnitude of the mid-span distortion of the open-closed specimen, then the seam reinforcement method shall be deemed to have no influence on mid-span pan distortion, and is therefore acceptable for use with the particular panel/seam/clip configuration being tested, regardless of panel gauge (thickness), material, seam spacing, or span. The method of seam reinforcement used on other tests must be identical to the validated seam reinforcement.

8.6 Overhangs at end conditions shall not exceed one-quarter of the span.

## 9. Calibration

9.1 The calibration of liquid column manometers, dial gages, and graduated scales or tape measures is not required for each test.<sup>12</sup>

## 10. Procedure

10.1 Omit from the test specimen any undue influence from gravity, sealing, or construction material that does not occur during actual installation.

10.1.1 If the test panel orientation is either inverted or vertical, a gravity correction, based upon the weight of the panel itself, shall be made in the determination of the allowable superimposed loading. Tests run in an inverted position shall include data from pressure reversal or an upright specimen to demonstrate that unlatching will not occur in the normal orientation.

<sup>10</sup> At the pressures used in this test method, considerable energy and hazard are involved. In cases of failure, the hazard to personnel is less with an exhaust system, as the specimen will tend to blow into the test chamber rather than out. Do not permit personnel in such chambers during the application of a pressure difference.

<sup>11</sup> The arbitrary length minimums in this section are based on tests of aluminum panels with structural elements 8 to 18-in. (203 to 457-mm) apart in nominal thicknesses from 0.0165 to 0.040 in. and of steel panels 12 to 24-in. (305 to 610-mm) apart in nominal thicknesses from 30 gage (0.0157 in.) to 22 gage (0.0336 in.). Additional testing or data (such as that listed in X1.6) may be required to validate appropriate lengths for products significantly outside these limits.

<sup>12</sup> The arbitrary length minimums in this section are based on tests of aluminum panels with structural elements 8 to 18-in. (203 to 457-mm) apart in nominal thicknesses from 0.0165 to 0.040 in. and of steel panels 12 to 24-in. (305 to 610-mm) apart in nominal thicknesses from 30 gage (0.0157 in.) to 22 gage (0.0336 in.). Additional testing or data (such as that listed in 8.3.2) may be required to validate appropriate lengths for products significantly outside these limits.

<sup>11</sup> The size of support members in this test method does not necessarily preclude the use of smaller members in actual installations. For negative loads, fastener withdrawal resistance can be calculated readily by conventional means, taking into account prying forces and actual material thickness and properties. In positive loading, due consideration must be given to the actual bearing area in the test.

<sup>12</sup> The size of support members in this test method does not necessarily preclude the use of smaller members in actual installations. For negative loads, fastener withdrawal resistance can be calculated readily by conventional means, taking into account prying forces and actual material thickness and properties. In positive loading, due consideration must be given to the actual bearing area in the test.

<sup>12</sup> Water density varies less than 0.5 % over the temperature range from 40 to 90°F (4.4 to 32°C) and the length of metal measurement devices varies even less. Persistent differences in pressure readings at opposite ends of a test chamber indicate uneven air flow within the chamber or leaks in the lines to the manometers. If reducing the rate of increase does not allow the pressure to stabilize, the test readings are suspect. Leaks in manometer lines produce readings that are less than the actual pressures.