**Road vehicles — Automotive multimedia
interface —**

Part 1:
General technical overview

Véhicules routiers — Interface multimédia pour l'automobile

Partie 1: Vue d'ensemble technique générale

iTeh STANDARD PREVIEW
(standards.iteh.ai)

ISO 22902-1:2006

<https://standards.iteh.ai/catalog/standards/sist/928f7686-c567-4114-ad31-c7e58e05da6a/iso-22902-1-2006>



PDF disclaimer

This PDF file may contain embedded typefaces. In accordance with Adobe's licensing policy, this file may be printed or viewed but shall not be edited unless the typefaces which are embedded are licensed to and installed on the computer performing the editing. In downloading this file, parties accept therein the responsibility of not infringing Adobe's licensing policy. The ISO Central Secretariat accepts no liability in this area.

Adobe is a trademark of Adobe Systems Incorporated.

Details of the software products used to create this PDF file can be found in the General Info relative to the file; the PDF-creation parameters were optimized for printing. Every care has been taken to ensure that the file is suitable for use by ISO member bodies. In the unlikely event that a problem relating to it is found, please inform the Central Secretariat at the address given below.

iTeh STANDARD PREVIEW
(standards.iteh.ai)

ISO 22902-1:2006

<https://standards.iteh.ai/catalog/standards/sist/928f7686-c567-4114-ad31-c7e58e05da6a/iso-22902-1-2006>

© ISO 2006

All rights reserved. Unless otherwise specified, no part of this publication may be reproduced or utilized in any form or by any means, electronic or mechanical, including photocopying and microfilm, without permission in writing from either ISO at the address below or ISO's member body in the country of the requester.

ISO copyright office
Case postale 56 • CH-1211 Geneva 20
Tel. + 41 22 749 01 11
Fax + 41 22 749 09 47
E-mail copyright@iso.org
Web www.iso.org

Published in Switzerland

Contents

Page

Foreword.....	iv
1 Scope	1
2 Normative references	1
3 Terms and definitions.....	2
3.1 Terms and definitions.....	2
3.2 Abbreviations	11
4 Introduction to the User Guide.....	13
5 General architecture	13
5.1 Architectural views	13
5.2 Structural view	13
5.3 Functional view	19
5.4 Application view of the architecture	24
6 System architecture configurations	27
7 Relationship between uses cases and interface specifications	27

iTeh STANDARD PREVIEW
(standards.iteh.ai)

[ISO 22902-1:2006](https://standards.iteh.ai/catalog/standards/sist/928f7686-c567-4114-ad31-c7e58e05da6a/iso-22902-1-2006)

<https://standards.iteh.ai/catalog/standards/sist/928f7686-c567-4114-ad31-c7e58e05da6a/iso-22902-1-2006>

Foreword

ISO (the International Organization for Standardization) is a worldwide federation of national standards bodies (ISO member bodies). The work of preparing International Standards is normally carried out through ISO technical committees. Each member body interested in a subject for which a technical committee has been established has the right to be represented on that committee. International organizations, governmental and non-governmental, in liaison with ISO, also take part in the work. ISO collaborates closely with the International Electrotechnical Commission (IEC) on all matters of electrotechnical standardization.

International Standards are drafted in accordance with the rules given in the ISO/IEC Directives, Part 2.

The main task of technical committees is to prepare International Standards. Draft International Standards adopted by the technical committees are circulated to the member bodies for voting. Publication as an International Standard requires approval by at least 75 % of the member bodies casting a vote.

Attention is drawn to the possibility that some of the elements of this document may be the subject of patent rights. ISO shall not be held responsible for identifying any or all such patent rights.

ISO 22902-1 was prepared by Technical Committee ISO/TC 22, *Road vehicles*, Subcommittee SC 3, *Electrical and electronic equipment*.

ISO 22902 consists of the following parts, under the general title *Road vehicles — Automotive multimedia interface*:

iTeh STANDARD PREVIEW
(standards.iteh.ai)

- *Part 1: General technical overview*
- *Part 2: Use cases*
- *Part 3: System requirements*
- *Part 4: Network protocol requirements for vehicle interface access*
- *Part 5: Common message set*
- *Part 6: Vehicle interface requirements*
- *Part 7: Physical specification*

Road vehicles — Automotive multimedia interface —

Part 1: General technical overview

1 Scope

This multimedia and telematics standard is based on the AMI-C specifications and reference documents for automotive industry.

It is established to facilitate the development, promotion and standardisation of automotive information and entertainment system interfaces to motor vehicle communication networks.

Technical glossary is a compilation of terms and definitions used in AMI-C technical publications.

User guide describes the organisation and classification and scope of the reference information for ISO specifications listed below.

Architectural overview describes the structural, functional, and applications views of the AMI-C architecture.

2 Normative references

[ISO 22902-1:2006](https://standards.iteh.ai/catalog/standards/sist/928f7686-c567-4114-ad31-c7e58e05da6a/iso-22902-1-2006)

<https://standards.iteh.ai/catalog/standards/sist/928f7686-c567-4114-ad31-c7e58e05da6a/iso-22902-1-2006>

The following referenced documents are indispensable for the application of this document. For dated references, only the edition cited applies. For undated references, the latest edition of the referenced document (including any amendments) applies.

ISO 22902-2, *Road vehicles — Automotive multimedia interface — Part 2: Use cases*

ISO 22902-3, *Road vehicles — Automotive multimedia interface — Part 3: System requirements*

ISO 22902-4, *Road vehicles — Automotive multimedia interface — Part 4: Network protocol requirements for vehicle interface access*

ISO 22902-5, *Road vehicles — Automotive multimedia interface — Part 5: Common message set*

ISO 22902-6, *Road vehicles — Automotive multimedia interface — Part 6: Vehicle interface requirements*

ISO 22902-7, *Road vehicles — Automotive multimedia interface — Part 7: Physical specification*

3 Terms and definitions

For the purposes of all parts of ISO 22902, the following terms and definitions apply.

3.1 Terms and definitions

3.1.1

1394 Automotive

the automotive version of IEEE 1394 network technology

3.1.2

AMI-C component

component that meets AMI-C specification(s)

3.1.3

AMI-C guideline

AMI-C statement of what should be done on a subject for which AMI-C adopts a standard or specification from another organization

3.1.4

AMI-C recommendation

AMI-C guideline that AMI-C proposes to another organization for adoption

3.1.5

AMI-C requirement

requirement of one or more interfaces for one or more elements in the architecture; requirements do not address performance and quality issues

3.1.6

AMI-C specification

automotive multimedia interface specification published for connecting or implementing information, communication, entertainment systems to motor vehicles

3.1.7

Application

distinct executable software element that provides functionality or utility to a user

3.1.8

architecture

description of the key elements of a system, their functions, and the interrelationships among the elements

3.1.9

ASN.1 Reference

the AMI-C CMS has been developed in ASN.1. In this textual document the messages are presented in a tabular format for readability. The CMS in ASN.1 is available as a download from the AMI-C web site, although ASN.1 has a large number of type definitions, only the following definitions are used in the AMI-C CMS

3.1.10

audio Gateway

[Bluetooth] device embedded with the Bluetooth transceiver that serves as the gateway (access) to the phone audio for both input and output; typically, devices acting as audio gateways are cellular or mobile phones these devices are implemented with the Hands-Free Profile

3.1.11

boolean

logical values TRUE and FALSE

**3.1.12
bundle**

[software] mechanism to organize the delivery of software to the platform/OSGi framework

**3.1.13
common message set
CMS**

sequence of network messages between two functional modules that enable the exchange of data

**3.1.14
Car Communication Application Promotion
CCAP**

Bluetooth Hands-Free phone application guideline for implementers to improve device interoperability and enhance customer convenience by providing consistent user experience

**3.1.15
choice**
between types

**3.1.16
common mode bulk current injection
CBCI**

test method used to determine a component's or subsystem's immunity to electromagnetic fields, "common mode" refers to the phase at which the signal is applied

**3.1.17
commonality**

the possession, along with one or more other systems, of a certain attribute or set of attributes: the characteristic of being a shared feature or attribute

iTeh STANDARD PREVIEW

(standards.iteh.ai)

**3.1.18
component**

a device that is one of the individual parts of which a vehicle is made up; especially a part that can be separated from or attached to a system

ISO 22902-1:2006
<https://standards.iteh.ai/catalog/standards/sist/928f7686-c567-4114-ad31-c7e58e05da6a/iso-22902-1-2006>

**3.1.19
configure-ability**

characteristic of a system that supports the rearrangement of features and attributes to support different features and uses

**3.1.20
consumer connector**

connector intended for use in applications where the consumer regularly mates and un-mates the connector for the purpose of installing and removing components or devices

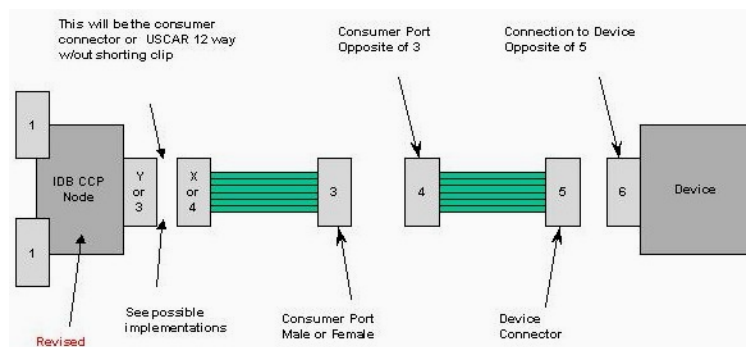

Figure 1 — Consumer device connection — General configuration

3.1.21

**consumer convenience port
CCP**

connection point for portable consumer devices to connect to an AMI-C network

3.1.22

controllers

computer-based units performing a dedicated function or feature

NOTE They frequently use network devices to gather information to control a system.

3.1.23

custom access adaptor

interface device between an AMI-C interface connector and an embedded device to a customer access connector

3.1.24

customer access connector

the connector accessible to a driver or passenger for the connection of an external or consumer device to an AMI-C compliant network system

NOTE It provides access to the system signal set (power, network data, power mode, etc.).

3.1.25

device

low-level components with little or no programmable intelligence

NOTE They are generally driven by other components and customer commands.

3.1.26

**differential Mode Bulk Current Injection
DBCi**

test method used to determine a component's or subsystem's immunity to electromagnetic fields

NOTE Differential mode refers to the phase at which the signal is applied.

3.1.27

embedded

components or devices that are installed by the automaker

3.1.28

embedded component

component installed in a vehicle by the vehicle manufacturer or service technician using conventional wiring and mounting technologies

3.1.29

embedded connector

separable interface that is an integral part of an embedded component or device

3.1.30

execution environment

(see software execution environment)

3.1.31

expandability

characteristic of a system that supports and/or facilitates the addition of new features and capabilities

3.1.32 functional module FM

an abstraction within the AMI-C network architecture that is used to address a device

EXAMPLE Audio-related functions such as accessing vehicle audio resources, changing volume, etc., are grouped in an audio functional module.

3.1.33 gateway

interface between two networks carrying different protocols

3.1.34 Hands-Free Car Kit HFCK

[Bluetooth] car kit composed of two major components:

- Hands-Free Unit (HFU): Device that the customer can use without need to manipulate by hands, the most well-known is hand free phone;
- User Interface (UI): Appropriate interface to facilitate complete phone operations from the hands-free unit.

3.1.35 Hands-Free Profile HFP

[Bluetooth] specification defining the minimum set of functions required to use a mobile phone together with a hands-free device in a car via a Bluetooth link

3.1.36 Hands-Free Unit HFU

[Bluetooth] device embedded with the Bluetooth transceiver and implemented with the Bluetooth Hands-Free Profile

NOTE The device serves as a remote unit to the audio gateway. It provides audio input, output and control functions of the audio gateway over the Bluetooth link.

3.1.37 host

general-purpose computers having the capability to execute a variety of application software

NOTE Hosts easily allow a user to select and change software on demand.

3.1.38 implementation

physical realization of a specification or specifications

3.1.39 instance number I-Num

a number statically or dynamically assigned to each functional module that shares the same function type

3.1.40 interchangeability

characteristic of a system that allows hardware and/or software components to be replaced by other components with no perceptible change in system function or performance

3.1.41 integer

whole numbers (positive or negative), possibly named

3.1.42

interoperability

characteristic of providing an intended function in coordination with other components, the characteristic of sharing information with other system functions or components to provide additional functionality

3.1.43

isochronous data

data that arrive at the destination at the same rate that they leave the source; the word “isochronous” means “of equal time”; isochronous data are used for streaming video and audio data

3.1.44

L2CAP

(see Logical Link Control and Adaptation Protocol)

3.1.45

link key

[Bluetooth] authentication key used to establish a link between devices

3.1.46

listener

[software] Java object that responds to external events such as a change in the host operating state OR an application with a well-defined interface that does something useful for another application of a user

3.1.47

local functional modules

functional modules that are within the same AML-C component

3.1.48

logical address

address used to identify a functional module and is made up of the combination of F-Type and I-Num

3.1.49

Logical Link Control and Adaptation Protocol

L2CAP

protocol supporting higher level protocol multiplexing, packet segmentation and reassembly, and the conveying of quality of service information

3.1.50

object body

has, Message Type (Msg Type), Message Class, Object Type and Operand

3.1.51

object type

an identification of object in a functional module

EXAMPLE In the case of body module, mirror, window, seat and so on.

3.1.52

octet string

byte strings

3.1.53

enumerated

enumeration of identifiers (state of a machine, for instance)

3.1.54

operand

data in a message

ITIH STANDARD PREVIEW
(standards.iteh.ai)

<https://standards.iteh.ai/catalog/standards/sist/928f7686-c567-4114-ad31-c7e58e05da6a/iso-22902-1-2006>

3.1.54.1**message type**

there are six kinds of message type for application messages; INQUIRE, REPORT, SET, CONFIRM, COMMAND, and WARNING

3.1.54.2**message class**

the message class shows a class within which a message is comprised, the message class defines thirteen types:

- Management – Network device management, audio/video stream management, and service discovery.
- Core – Information that are originally inherent in a vehicle (VIN, static configuration information, etc.).
- Body Module – Control and status related with body module (window, seat, mirror, light, trip meter, vehicle speed, etc.).
- Powertrain – Status related with powertrain (Oil temperature, coolant temperature, gear, etc.).
- Vehicle Diagnostics – Message for vehicle diagnostic (ISO 15031-5 emission related, ISO 14229-1 non emission related).
- Amplifier – Control related with amplifier and codec (volume, fade/balance, codec, etc.).
- General Player – Common functions for disk and tape player.
- Disk Media – Audio/video player for disk media (CD, MD, DVD, MP3, etc.).
- Tape Media – Audio/video player for tape media (audio tape, VCR, etc.).
- Tuner – Audio/video broadcast tuner (AM, FM, XM, TV, etc.).
- General Phone – Basic phone functionality (dial, hang-up, phone book, etc.).
- Advanced Phone – Advanced phone functionality (short message, multi party call, conference call, etc.).
- Text Display – Command to display simple texts and input texts.

3.1.55**mode**

the power level of a system, modes include ON, OFF, and SLEEP; a system is in a mode, a device or a component is in a state

3.1.56**modularity**

exhibiting separable functions embodied within discrete and removable hardware or software components or modules

3.1.57**MSC**

Modem Status Command

3.1.58**network adaptation layer**

network layer that adapts the messages from the functional modules to those of the network specific layer and resolves addressing issues (optional use of a registry)

3.1.59

network transport layer

network layer that puts network transactions in packets according to the network transport protocols of the specific network

3.1.60

network transaction

sequence of network messages between two functional modules enabling the exchange of data

3.1.61

network transaction

CBCI

See common mode bulk current injection

3.1.62

NULL

Includes the single value NULL, used for delivery report or some alternatives of the CHOICE type (particularly for the recursive types)

3.1.63

operability

the capability of being used or operated effectively to provide an intended result or function

3.1.64

pairing

[Bluetooth] the creation and exchange of a link key between two devices; the devices use the link key for future authentication when exchanging information

3.1.65

PMODE line

signal wire used to control and sense wake-up and sleep states in an AMI-C system

3.1.66

PMODE signal

signal carried by the PMODE line or optionally a signal on the AMI-C network identifying the power mode of the network

3.1.67

portability

characteristic of a component or a solution that allows it to be used effectively in multiple locations or application venues

3.1.68

preference

default value preferred by a user, such as a radio preset value

3.1.69

preference service

service that returns the preferences for a given vehicle occupant

3.1.70

proof-of-concept implementation

implementation to validate requirements and/or specifications

3.1.71

radio frequency communication

[Bluetooth] the radio frequency oriented emulation of an RS232 serial communication over an L2CAP channel