International Standard



234/2

INTERNATIONAL ORGANIZATION FOR STANDARDIZATION • МЕЖДУНАРОДНАЯ ОРГАНИЗАЦИЯ ПО СТАНДАРТИЗАЦИИ • ORGANISATION INTERNATIONALE DE NORMALISATION

**Files and rasps —
Part 2 : Characteristics of cut**

Limes et râpes — Partie 2 : Caractéristiques de taille

First edition — 1982-05-15

iTeh STANDARD PREVIEW
(standards.iteh.ai)

ISO 234-2:1982

<https://standards.iteh.ai/catalog/standards/sist/a0e0e2c0-a93e-4b97-b478-757ee5c6ee74/iso-234-2-1982>

UDC 621.918.2

Ref. No. ISO 234/2-1982 (E)

Descriptors : tools, hand tools, files (tools), dimensions, shape, length, cutting angle, characteristics.

Foreword

ISO (the International Organization for Standardization) is a worldwide federation of national standards institutes (ISO member bodies). The work of developing International Standards is carried out through ISO technical committees. Every member body interested in a subject for which a technical committee has been set up has the right to be represented on that committee. International organizations, governmental and non-governmental, in liaison with ISO, also take part in the work.

Draft International Standards adopted by the technical committees are circulated to the member bodies for approval before their acceptance as International Standards by the ISO Council.

International Standard ISO 234/2 (formerly draft International Standard ISO/DIS 6350) was developed by Technical Committee ISO/TC 29, *Small tools*, and was circulated to the member bodies in March 1980.

It has been approved by the member bodies of the following countries :

Australia	India	South Africa, Rep. of
Belgium	Israel	Spain
Czechoslovakia	Italy	Sweden
Finland	Korea, Rep. of	United Kingdom
France	Mexico	USSR
Germany, F.R.	Netherlands	
Hungary	Romania	

The member bodies of the following countries expressed disapproval of the document on technical grounds :

Austria
Poland

Files and rasps — Part 2 : Characteristics of cut

1 Scope and field of application

This International Standard covers the coarseness of cuts for the more common files and rasps. The terms used for types of files and rasps and coarseness of cut correspond to the traditional terminology in the trade.

This International Standard applies only to those forms of files and rasps indicated in clause 4 for each tool type.

2 Reference

ISO 234/1, *Files and rasps — Part 1 : Dimensions*.¹⁾

3 Definitions

3.1 principal cut : The cut on the flat side of a single-cut file or the second cut superimposed on the first cut on a double-cut file. Principal cut corresponds to the English term "upcut", the French term "deuxième taille" and the German term "Oberhieb".

3.2 cutting angle : The angle between the principal cut and the centre line of the file (see figure).

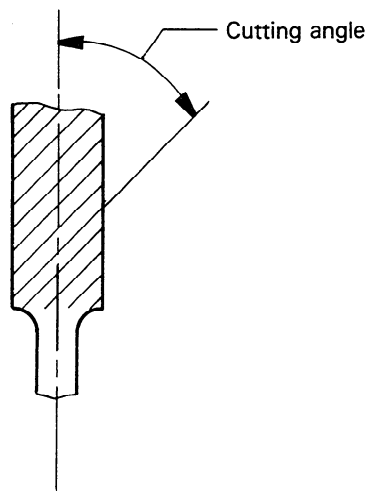

3.3 coarseness of cut for files : Number of teeth of the principal cut per centimetre along the centre line of the file.

3.4 coarseness of cut for rasps : Number of teeth per square centimetre on the non-tapered part of the rasp equivalent to

$$\frac{1\ 000 (n - 1)}{L \times W}$$

where

n is the number of teeth in each row;

L is the distance in millimetres measured between the top of a tooth of the first and the eleventh row;

W is the distance in millimetres between the top of the first and the last tooth in a row.

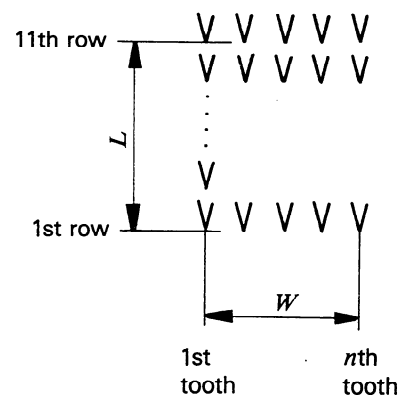

1) At present at the stage of draft. (Revision of ISO 234-1975.)

4 Coarseness of cut

4.1 Engineers' files (double cut)

Hand, flat, half-round, round, square, three-square.

Tolerances on cut : $\pm 8\%$

Cutting angle : $65^\circ \pm 5^\circ$

Coarseness of cut on edges in case the edges are cut :

The same number of teeth as for principal cut but with a tolerance of + 20 %.

Cutting angle on the edge : $90^\circ \pm 10^\circ$

Length		Number of teeth per centimetre		
mm	inch	bastard	second	smooth
100	4	17	22	28
150	6	13	18	22
200	8	10	14	18
250	10	9	12	16
300	12	8	11	14
350	14	7	10	13

4.2 Mill files (single cut)

Taper or blunt, flat section with square or round edges or one round edge.

Tolerances on cut : $\pm 5\%$

Cutting angle : $60^\circ \pm 5^\circ$

Coarseness of cut on edges :

The same number of teeth as for principal cut but with a tolerance of + 20 %.

Length		Number of teeth per centimetre	
mm	inch	bastard	second
150	6	20	24
200	8	18	20
250	10	16	18
300	12	14	16
350	14	12	14

4.3 Taper saw files (single cut)

Triangular section.

Tolerances on cut : $\pm 5\%$

Cutting angle : $60^\circ \pm 5^\circ$

Coarseness of cut on edges :

The same number of teeth as for principal cut but with a tolerance of + 20 %.

Length		Number of teeth per centimetre		
mm	inch	regular	slim	extra slim
100	4	20	23	26
125	5	19	22	24
150	6	17	20	22
175	7	16	19	21
200	8	15	17	20
250	10	14	16	—

4.4 Wood rasps

Flat, half-round, round, cabinet.

Tolerances on cut : $\pm 12\%$

Coarseness of cut on edges :

The number of teeth per centimetre along the edges of the rasp is $(70 \pm 12)\%$ of the number of teeth per square centimetre of the rasp cut.

Length		Number of teeth per square centimetre		
mm	inch	coarse	medium	fine
150	6	14	20	28
200	8	10	16	22
250	10	8	12	18
300	12	6	10	14

iTeh STANDARD PREVIEW
(standards.iteh.ai)

ISO 234-2
<https://standards.iteh.ai/catalog/standards/sis/a00c239-493e-4917-0470-757ee5c6ee74/iso-234-2-1982>