

---

# INTERNATIONAL STANDARD



# 239

---

INTERNATIONAL ORGANIZATION FOR STANDARDIZATION • МЕЖДУНАРОДНАЯ ОРГАНИЗАЦИЯ ПО СТАНДАРТИЗАЦИИ • ORGANISATION INTERNATIONALE DE NORMALISATION

---

## Drill chuck tapers

*Cônes d'emmanchement pour mandrins de perceuses*

First edition — 1974-12-01

ITeH STANDARD PREVIEW  
(standards.iteh.ai)

[ISO 239:1974](#)

<https://standards.iteh.ai/catalog/standards/sist/0e620cc2-01e1-4ea7-9845-1f11d36697a/iso-239-1974>



---

UDC 621-229.2

Ref. No. ISO 239-1974 (E)

**Descriptors** : tools, drills, chucks, cones, dimensions.

## FOREWORD

ISO (the International Organization for Standardization) is a worldwide federation of national standards institutes (ISO Member Bodies). The work of developing International Standards is carried out through ISO Technical Committees. Every Member Body interested in a subject for which a Technical Committee has been set up has the right to be represented on that Committee. International organizations, governmental and non-governmental, in liaison with ISO, also take part in the work.

Draft International Standards adopted by the Technical Committees are circulated to the Member Bodies for approval before their acceptance as International Standards by the ISO Council.

Prior to 1972, the results of the work of the Technical Committees were published as ISO Recommendations; these documents are now in the process of being transformed into International Standards. As part of this process, Technical Committee ISO/TC 29 has reviewed ISO Recommendation R 239 and found it technically suitable for transformation. International Standard ISO 239 therefore replaces ISO Recommendation R 239-1961 to which it is technically identical.

[https://standards.iteh.ai/catalog/standards/sist/0e620cc2-01e1-4ea7-9845-](https://standards.iteh.ai/catalog/standards/sist/0e620cc2-01e1-4ea7-9845-1f11d36697a/iso-239-1974)

ISO Recommendation R 239 was approved by the Member Bodies of the following countries :

Austria	India	Romania
Belgium	Italy	Sweden
Czechoslovakia	Mexico	Switzerland
France	Netherlands	United Kingdom
Germany	Pakistan	U.S.A.
Greece	Poland	U.S.S.R.
Hungary	Portugal	

No Member Body expressed disapproval of the Recommendation.

No Member Body disapproved the transformation of ISO/R 239 into an International Standard.

# Drill chuck tapers

## iTeh STANDARD PREVIEW (standards.iteh.ai)

### 1 SCOPE AND FIELD OF APPLICATION

This International Standard lays down the dimensions of drill chuck tapers and includes two distinct types:

- 1) Morse taper type;
- 2) Jacobs taper type.

It comprises, for each type of taper, two tables giving respectively the dimensions in millimetres and the corresponding dimensions in inches.

### 2 INTERCHANGEABILITY

For each type of taper, Morse or Jacobs, complete interchangeability is assured between the two systems of units of measurement, millimetres and inches, as the dimensions expressed in any one system have been converted from those expressed in the other with sufficiently close approximation, having regard to the magnitude of the tolerances.

### 2.1 Morse taper type

The tapered portions are identical with the following Morse tapers:

- No. 1, for tapers B10 and B12;
- No. 2, for tapers B16 and B18;
- No. 3, for tapers B22 and B24.

The length of each of these tapers is, of course, distinctly less than the overall length of the corresponding Morse taper; each taper may be regarded as corresponding approximately either to that part of the Morse taper nearest the small end (for example : B10), or to the part nearest the large end (for example : B12).

### 2.2 Jacobs taper type

The tables in 4.1 and 4.2 merely reproduce and classify the normal dimensions of Jacobs tapers; they also observe the generally accepted designations, in spite of their somewhat illogical appearance.

In effect, the range of increasing values for diameter  $D$  contains two 2 tapers, the first of which is a short taper 2, and between the tapers 2 and 3, there are two interpolated tapers which bear the out-of-series numbers 33 and 6 respectively.

3 MORSE TAPER TYPE

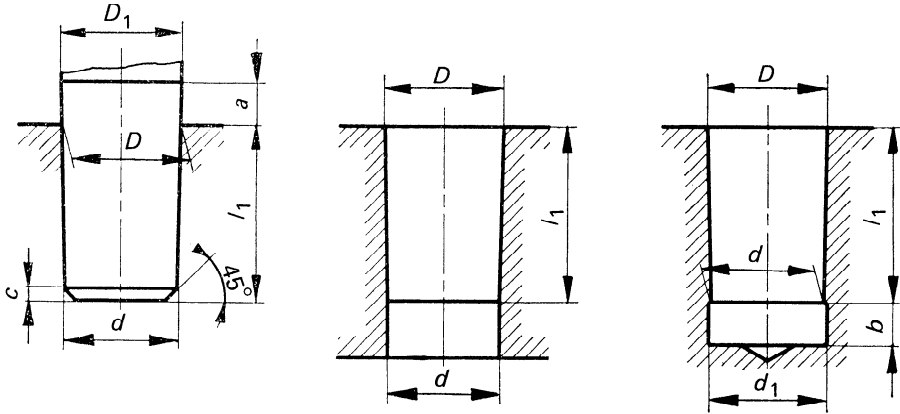

3.1 Dimensions in millimetres

Reference No.	D	D <sub>1</sub> *	d*	d <sub>1</sub>	l <sub>1</sub>	a max.	b	c	Morse No.	Taper on diameter
B10	10,094	10,3	9,4	9,8	14,5	3,5	3,5	1,0	1	0,049 88
B12	12,065	12,2	11,1	11,5	18,5					
B16	15,733	16,0	14,5	15,0	24,0	5,0	4,0	1,5	2	0,049 95
B18	17,780	18,0	16,2	16,8	32,0					
B22	21,793	22,0	19,8	20,5	40,5	5,0	4,5	2,0	3	0,050 20
B24	23,825	24,1	21,3	22,0	50,5					

3.2 Dimensions in inches

Reference No.	D	D <sub>1</sub> *	d*	d <sub>1</sub>	l <sub>1</sub>	a max.	b	c	Morse No.	Taper on diameter
B10	0.397 4	0.403 6	0.368 9	<sup>25</sup> / <sub>64</sub>	0.571	1/8	1/8	3/64	1	0.049 88
B12	0.475 0	0.481 2	0.438 7	<sup>29</sup> / <sub>64</sub>	0.728					
B16	0.619 4	0.628 8	0.572 2	<sup>19</sup> / <sub>32</sub>	0.945	3/16	5/32	1/16	2	0.049 95
B18	0.700 0	0.709 4	0.637 1	<sup>21</sup> / <sub>32</sub>	1.260					
B22	0.858 0	0.867 4	0.778 0	<sup>13</sup> / <sub>16</sub>	1.594	3/16	3/16	5/64	3	0.050 20
B24	0.938 0	0.947 4	0.838 2	7/8	1.988					

\* D<sub>1</sub> and d = calculated values given for information.

(The effective values are obtained by applying the rate of taper and the basic dimension D to the actual values of a and l<sub>1</sub> respectively.)

4 JACOBS TAPER TYPE

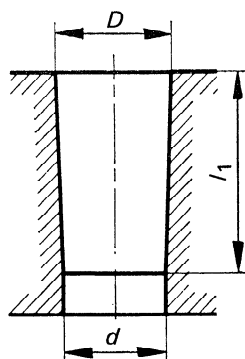

4.1 Dimensions in millimetres

Jacob's taper No.	$D$	$d$ ≈	$l_1$	Taper on diameter
0	6,350	5,802	11,112	0,049 29
1	9,754	8,469	16,669	0,077 09
2 short	13,940	12,386	19,050	0,081 55
2	14,199	12,386	22,225	0,081 55
33	15,850	14,237	25,400	0,063 50
6	17,170	15,852	25,400	0,051 91
3	20,599	18,951	30,956	0,053 25
(4)	28,550	26,346	42,069	0,052 40
(5)	35,890	33,422	47,625	0,051 83

Sizes shown in brackets should be avoided whenever possible.

4.2 Dimensions in inches

Jacob's taper No.	$D$	$d$ ≈	$l_1$	Taper on diameter
0	0.250 0	0.228 4	0.437 50	0.591 45
1	0.384 0	0.333 4	0.656 25	0.925 08
2 short	0.548 8	0.487 6	0.750 00	0.978 61
2	0.559 0	0.487 6	0.875 00	0.978 61
33	0.624 0	0.560 5	1.000 00	0.761 94
6	0.676 0	0.624 1	1.000 00	0.622 92
3	0.811 0	0.746 1	1.218 75	0.638 98
(4)	1.124 0	1.037 2	1.656 25	0.628 86
(5)	1.413 0	1.316 1	1.875 00	0.620 10

Sizes shown in brackets should be avoided whenever possible.

## iTeh STANDARD PREVIEW

This page intentionally left blank  
(standards.iteh.ai)

ISO 239:1974

<https://standards.iteh.ai/catalog/standards/sist/0e620cc2-01e1-4ea7-9845-1f11d36697a/iso-239-1974>

## iTeh STANDARD PREVIEW

This page intentionally left blank  
(standards.iteh.ai)

ISO 239:1974

<https://standards.iteh.ai/catalog/standards/sist/0e620cc2-01e1-4ea7-9845-1f11d36697a/iso-239-1974>

## iTeh STANDARD PREVIEW

This page intentionally left blank  
(standards.iteh.ai)

ISO 239:1974

<https://standards.iteh.ai/catalog/standards/sist/0e620cc2-01e1-4ea7-9845-1f11d36697a/iso-239-1974>