



Designation: F1342 – 05

Standard Test Method for Protective Clothing Material Resistance to Puncture¹

This standard is issued under the fixed designation F1342; the number immediately following the designation indicates the year of original adoption or, in the case of revision, the year of last revision. A number in parentheses indicates the year of last reapproval. A superscript epsilon (ϵ) indicates an editorial change since the last revision or reapproval.

1. Scope

1.1 This test method determines the puncture resistance of a protective clothing material specimen by measuring the force required to cause a pointed puncture probe to penetrate through the specimen. This test method describes three protocols that may be used: Method A, Method B, and Method C.

1.1.1 Method A requires the use of Probe A only. The probe used for testing shall be recorded in the test report.

1.1.1.1 Probe A may be used to measure puncture resistance for the following types of materials:

- (1) Elastomeric materials
- (2) Textiles
- (3) Coated materials

1.1.2 Method B requires the use of Probe B. The probe used for testing shall be recorded in the test report.

1.1.2.1 Probe B may be used to measure puncture resistance for the following types of materials:

- (1) Textiles
- (2) Coated materials

NOTE 1—Probe B is not suited for measuring the puncture resistance of unsupported elastomeric materials.

1.2 The values stated in SI units are to be regarded as the standard. The values in inch-pound units in brackets are for information purposes only. The values stated in each system may not be exact equivalents; therefore, each system must be used independently of the other, without combining values in any way.

1.3 *This standard does not purport to address all of the safety concerns, if any, associated with its use. It is the responsibility of the user of this standard to establish appropriate safety and health practices and determine the applicability of regulatory limitations prior to use.*

¹ This test method is under the jurisdiction of ASTM Committee F23 on Personal Protective Clothing and Equipment and is the direct responsibility of Subcommittee F23.20 on Physical.

Current edition approved May 1, 2005. Published June 2005. Originally approved in 1991. Last previous edition approved in 1996 as F1342 91 (96)*². DOI: 10.1520/F1342-05.

2. Referenced Documents

2.1 *ASTM Standards*:²

D2582 Test Method for Puncture-Propagation Tear Resistance of Plastic Film and Thin Sheeting

D3767 Practice for Rubber—Measurement of Dimensions

3. Terminology

3.1 *Definitions*:

3.1.1 *protective clothing material, n*—any element, constituent, or substance from which protective clothing is composed or can be made.

4. Summary of Test Method

4.1 A material specimen is placed in a stationary support assembly that is in turn affixed to the lower arm of a tension testing machine.

4.2 A pointed puncture probe of set dimensions is mounted to the test fixture and the whole assembly is attached to the compression cell of the testing machine.

4.3 The puncture probe is moved at a constant velocity until it punctures the material specimen.

4.4 The force required to puncture the material specimen is measured by the compression cell. The elongation (or deflection) of the specimen prior to puncture is also measured. The reported puncture resistance is the average of twelve test replicates.

5. Significance and Use

5.1 This test method evaluates puncture resistance of protective clothing materials which may include plastics or elastomeric films, coated fabrics, flexible materials, laminates, or textile materials.

5.2 This test method is not intended to measure puncture resistance of all types of punctures encountered using protective clothing material. This test method involves a procedure

² For referenced ASTM standards, visit the ASTM website, www.astm.org, or contact ASTM Customer Service at service@astm.org. For *Annual Book of ASTM Standards* volume information, refer to the standard's Document Summary page on the ASTM website.

where a puncture probe of specified dimensions is used for puncturing specimens.

5.3 This test method evaluates puncture resistance of protective clothing materials, specifically for puncture forced on specimens perpendicular to material surface. There is no supporting structure under the material specimen.

5.4 Evaluation of puncture resistance for snag-type puncture should be performed in accordance with Test Method D2582.

6. Apparatus

6.1 *Thickness Gage*, suitable for measuring thickness to the nearest 0.01 mm [or the nearest 0.001 in.], as specified in Test Method D3767, shall be used to determine the thickness of each protective clothing specimen tested.

6.2 *Testing Machine*, shall meet the following criteria:

6.2.1 It shall be capable of holding the specimen securely between the two clamps and be capable of straining the specimen with a uniform movement.

6.2.2 A machine capable of providing load versus elongation data until point of rupture shall be used.

6.2.3 The error of the machine shall not exceed 2 % at any reading within its loading range.

6.2.4 It shall be outfitted with a compression cell. The testing machine may be configured with the compression cell on either the lower or upper arm. The compression cell shall have a range sufficient enough to penetrate the specimen.

6.3 *Puncture Probes*:

6.3.1 *Probe A*, shall be fabricated to meet the dimensions shown in Fig. 1. The puncture probe shall be fabricated from stainless steel with a Rockwell Hardness of not less than 35.

6.3.2 *Probe B*, shall be fabricated to meet the dimensions shown in Fig. 2. The puncture probe shall be fabricated from stainless steel with a Rockwell Hardness of not less than 35.

6.3.3 *Probe C*, shall be fabricated to meet the dimensions shown in Fig. 3. The puncture probe shall be fabricated from stainless steel with a Rockwell Hardness of not less than 35.

6.3.4 See Fig. 4 for cross-section of probe and holder.

6.4 *Specimen Support Assembly*, shall consist of two flat metal specimen support plates (see Fig. 5) that clamp together so the sample specimen is held tightly between them. It shall also consist of a machine interface plate that can be connected to the testing machine. There should be enough distance to allow for 25 mm [1 in.] of travel of the probe.

6.4.1 Each plate shall have one to three chamfered holes measuring 6.4 mm [0.25 in.] for Probe A and 10 mm [0.39 in.] for Probes B and C. For efficiency in testing, three holes spaced at the points for a 60° equilateral triangle may be used, such that each hole is 25 mm [1 in.] from the other and from the edge of the specimen plate, as shown in Fig. 5.

6.4.2 The two specimen support plates shall be connected to the testing machine using a machine interface plate.

7. Test Specimens

7.1 Four to twelve test specimens, of dimensions to the specimen support assembly, shall be prepared. The samples should be of a size that will not show puckering or slippage of samples during the test. No sample conditioning is required.

7.2 Use the specimen support plate as a template to cut test specimens.

8. Procedure

8.1 *Test Method A*, use Probe A:

8.1.1 Measure the thickness of each specimen at the puncture point (prior to puncture) to the nearest 0.01 mm [0.001 in.] and record.

8.1.2 Mount the material specimen to be tested in the support assembly as shown in Fig. 6. Take care that the holes of the specimen support assembly are aligned prior to testing to avoid damaging the probe and plates.

8.1.3 Attach the material support assembly to the test apparatus.

8.1.4 Position puncture probe on the compression cell of the test apparatus, as shown in Fig. 6.

8.1.5 Set the testing machine in operation, but stop it when the probe has been driven through the sample specimen or traveled a distance of 20 mm [0.79 in.]. This ensures that none of the equipment will be damaged. The probe shall have a velocity of 50.8 cm/min [20 in./min] under load conditions and this speed shall be uniform at all times.

8.1.6 Record the maximum load registered by the indicating device to the nearest 50 g [0.1 lb] for each determination.

8.1.7 Record the deflection of the sample to the nearest 5 mm [0.2 in.] prior to puncture.

8.1.8 If the sample specimen has not been penetrated, record the maximum load of the load cell capacity. If the force of the load cell is insufficient to penetrate the specimen, change the load cell and indicate the source of the load cell.

8.1.9 Conduct a total of twelve puncture resistance measurements.

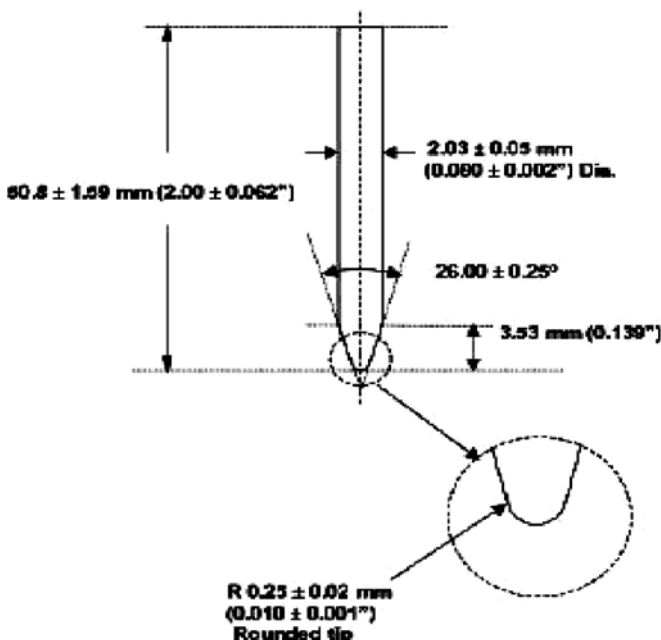

FIG. 1 Cross-Section of Puncture Probe A