**Textile machinery and accessories —
Beams for winding —**

Part 5:
**Sectional beams for warp knitting
machines**

*Matériel pour l'industrie textile — Ensouples pour enroulement —
Partie 5: Ensouples sectionnelles pour métiers à mailles jetées*

*iTeh STANDARD PREVIEW
(standards.iteh.ai)
Full standard: <https://standards.iteh.ai/catalog/standards/sist/b0-a918-01-2019/iso-8116-5-2008>
0bdb-4837-b055-498235f99f73/iso-8116-5-2008*

PROOF/ÉPREUVE



PDF disclaimer

This PDF file may contain embedded typefaces. In accordance with Adobe's licensing policy, this file may be printed or viewed but shall not be edited unless the typefaces which are embedded are licensed to and installed on the computer performing the editing. In downloading this file, parties accept therein the responsibility of not infringing Adobe's licensing policy. The ISO Central Secretariat accepts no liability in this area.

Adobe is a trademark of Adobe Systems Incorporated.

Details of the software products used to create this PDF file can be found in the General Info relative to the file; the PDF-creation parameters were optimized for printing. Every care has been taken to ensure that the file is suitable for use by ISO member bodies. In the unlikely event that a problem relating to it is found, please inform the Central Secretariat at the address given below.

iTeh STANDARD PREVIEW
(standards.iteh.ai)
Full standard:
<https://standards.iteh.ai/catalog/standards/sist/b0a91832-0bdb-4837-b055-498235f99f73/iso-8116-5-2008>



COPYRIGHT PROTECTED DOCUMENT

© ISO 2008

All rights reserved. Unless otherwise specified, no part of this publication may be reproduced or utilized in any form or by any means, electronic or mechanical, including photocopying and microfilm, without permission in writing from either ISO at the address below or ISO's member body in the country of the requester.

ISO copyright office
Case postale 56 • CH-1211 Geneva 20
Tel. + 41 22 749 01 11
Fax + 41 22 749 09 47
E-mail copyright@iso.org
Web www.iso.org

Published in Switzerland

Foreword

ISO (the International Organization for Standardization) is a worldwide federation of national standards bodies (ISO member bodies). The work of preparing International Standards is normally carried out through ISO technical committees. Each member body interested in a subject for which a technical committee has been established has the right to be represented on that committee. International organizations, governmental and non-governmental, in liaison with ISO, also take part in the work. ISO collaborates closely with the International Electrotechnical Commission (IEC) on all matters of electrotechnical standardization.

International Standards are drafted in accordance with the rules given in the ISO/IEC Directives, Part 2.

The main task of technical committees is to prepare International Standards. Draft International Standards adopted by the technical committees are circulated to the member bodies for voting. Publication as an International Standard requires approval by at least 75 % of the member bodies casting a vote.

Attention is drawn to the possibility that some of the elements of this document may be the subject of patent rights. ISO shall not be held responsible for identifying any or all such patent rights.

ISO 8116-5 was prepared by Technical Committee ISO/TC 72, *Textile machinery and accessories*, Subcommittee SC 3, *Machinery for fabric manufacturing including preparatory machinery and accessories*.

This third edition cancels and replaces the second edition (ISO 8116-5:1995), which has been technically revised.

ISO 8116 consists of the following parts, under the general title *Textile machinery and accessories — Beams for winding*:

- *Part 1: General vocabulary*
- *Part 2: Warper's beams*
- *Part 3: Weaver's beams*
- *Part 4: Test methods and quality classification of flanges for weaver's beams, warper's beams and sectional beams*
- *Part 5: Sectional beams for warp knitting machines*
- *Part 6: Beams for ribbon weaving and ribbon knitting*
- *Part 7: Beams for dyeing slivers, rovings and yarns*
- *Part 8: Definitions of run-out tolerances and methods of measurement*
- *Part 9: Dyeing beams for textile fabrics*

iTeh STANDARD PREVIEW
(standards.iteh.ai)

Full standard:
<https://standards.iteh.ai/catalog/standards/sist/b0a91832-0bdb-4837-b055-498235f99f73/iso-8116-5-2008>

Textile machinery and accessories — Beams for winding —

Part 5: Sectional beams for warp knitting machines

1 Scope

This part of ISO 8116 specifies the main dimensions, mechanical strength, designation and permissible values of tolerances of form and position for the main elements of sectional beams for warp knitting machines. For cases where a limit must be fixed for the residual imbalance, a recommendation is made for the choice of quality grade.

2 Normative references

The following referenced documents are indispensable for the application of this document. For dated references, only the edition cited applies. For undated references, the latest edition of the referenced document (including any amendments) applies.

ISO 286-2, *ISO system of limits and fits — Part 2: Tables of standard tolerance grades and limit deviations for holes and shafts*

ISO 1940-1, *Mechanical vibration — Balance quality requirements for rotors in a constant (rigid) state — Part 1: Specification and verification of balance tolerances*

ISO 8116-4, *Textile machinery and accessories — Beams for winding — Part 4: Test methods and quality classification of flanges for weaver's beams, warper's beams and sectional beams*

ISO 8116-8, *Textile machinery and accessories — Beams for winding — Part 8: Definitions of run-out tolerances and methods of measurement*

3 Main dimensions

The main dimensions of the sectional beams are given and explained in Figure 1.

The main dimensions of the sectional beams given in Table 1 shall be met.

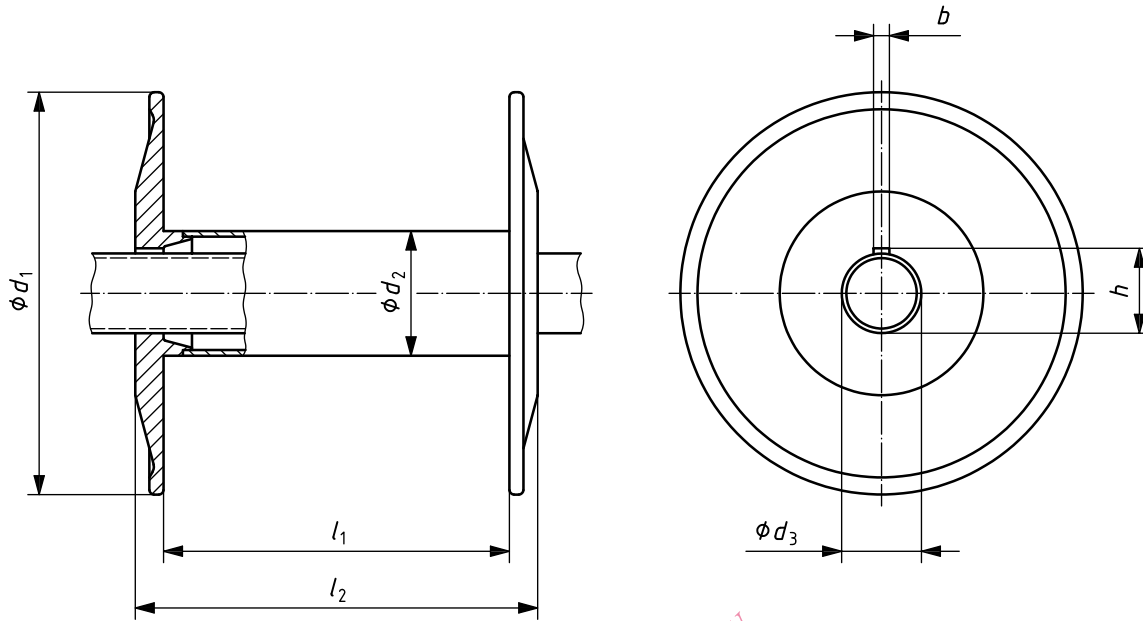

Key

- d_1 flange diameter
- d_2 outside barrel diameter
- d_3 bore diameter of flange
- l_1 length between flanges
- l_2 overall length
- b width of keyway
- h d_3 + keyway depth

Figure 1 — Sectional beam

Table 1 — Main dimensions

Dimensions in millimetres

d_1 ± 3	l_2 ± 1	d_2^a min	d_3 H11 ^b	b min	h min
355	355 535	110	70,4	14,2	75
532	535 1 065 1 270 1 325	196	152,7	19,6	165,3
762	1 065	298			
1 000	1 270 1 325	360			

^a Minimum values depending on the setting device of the machine.

^b Standard tolerance grades and limit deviations in accordance with ISO 286-2.

4 Mechanical strength

The mechanical strength of sectional beams for knitting machines is classified in accordance with the quality classes defined in ISO 8116-4. The mechanical strength of sectional beams for knitting machines shall be verified, depending on the quality class, by the test method given in ISO 8116-4.

5 Circular axial run-out tolerance, T_a , of flanges

The permissible circular axial run-out tolerance, T_a , of flanges given in with Table 2 shall be met.

The run-out tolerance shall be measured in accordance with ISO 8116-8.

Table 2 — Permissible circular axial run-out tolerance of flanges

d_1 mm	T_a mm
335	0,2
532	0,35
762	0,5
1 000	0,75

6 Total run-out tolerance, T_r , of barrel

The permissible total run-out tolerance, T_r , of the barrel shall be measured in millimetres and calculated using Equation (1):

$$T_r = \frac{0,25 \times l_1}{1000} \quad (1)$$

The run-out tolerance shall be measured in accordance with ISO 8116-8.

7 Residual imbalance

Depending on the circumstances, it may be necessary to fix a value for the residual imbalance of sectional beams. In general, a quality grade G 6,3 in accordance with ISO 1940-1 will be appropriate. If special conditions call for another grade, this shall be specified.

8 Taper reception

At a flange diameter, d_1 , of 762 mm or greater, the sectional beam may be designed with a taper reception as given in Figure 2 in order to achieve a better centring on mandrel.

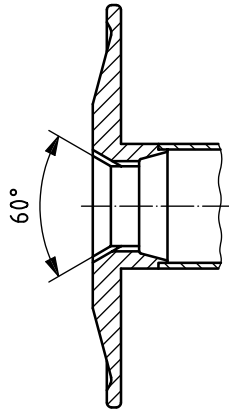

Figure 2 — Taper reception

9 Other specifications

The following details should be specified as appropriate:

- a) materials of the barrel and flanges;
- b) nature of the material to be wound;
- c) fabrication process of the sectional beam flanges (casting or forging);
- d) surface quality and, if possible, the treatment (paint, chromium-plating, nickel-plating, etc.) of the beam in contact with the material to be wound (inner sides of the flanges and the surface of the outside barrel diameter);
- e) number of grooves (one or two) to be included in the boss of each flange;
- f) taper reception (if received).

10 Designation

The designation of a sectional beam in accordance with this part of ISO 8116 shall include the following information in the order given:

- a) "Sectional beam";
- b) reference to this part of ISO 8116, i.e. ISO 8116-5;
- c) flange diameter, d_1 , in millimetres;
- d) overall length, l_2 , in millimetres;
- e) quality class Q1, Q2, Q3 or Q4 in accordance with ISO 8116-4.

EXAMPLE A sectional beam for warp knitting machines with flange diameter $d_1 = 535$ mm and overall length $l_2 = 1\ 065$ mm with the quality class Q4 shall be designated as follows:

Sectional beam ISO 8116-5 - 535 × 1 065-Q4

iTeh STANDARD PREVIEW
(standards.iteh.ai)

Full standard:
<https://standards.iteh.ai/catalog/standards/sist/b0a91832-0bdb-4837-b055-498235f99f73/iso-8116-5-2008>