

---

---

**Brown coals and lignites —  
Determination of moisture content —**

**Part 2:  
Indirect gravimetric method for moisture  
in the analysis sample**

iTeh STANDARD PREVIEW  
(standards.iteh.ai)

*Charbons bruns et lignites — Détermination de l'humidité —*

*Partie 2. Méthode gravimétrique indirecte pour l'humidité de l'échantillon  
d'analyse*

[ISO 5068-2:2007](#)

<https://standards.iteh.ai/catalog/standards/sist/6aa6967f-7fd6-46ff-aff2-702ddf245f70/iso-5068-2-2007>



**PDF disclaimer**

This PDF file may contain embedded typefaces. In accordance with Adobe's licensing policy, this file may be printed or viewed but shall not be edited unless the typefaces which are embedded are licensed to and installed on the computer performing the editing. In downloading this file, parties accept therein the responsibility of not infringing Adobe's licensing policy. The ISO Central Secretariat accepts no liability in this area.

Adobe is a trademark of Adobe Systems Incorporated.

Details of the software products used to create this PDF file can be found in the General Info relative to the file; the PDF-creation parameters were optimized for printing. Every care has been taken to ensure that the file is suitable for use by ISO member bodies. In the unlikely event that a problem relating to it is found, please inform the Central Secretariat at the address given below.

**iTeh STANDARD PREVIEW**  
**(standards.iteh.ai)**

ISO 5068-2:2007

<https://standards.iteh.ai/catalog/standards/sist/6aa6967f-7fd6-46ff-af2-702ddf245f70/iso-5068-2-2007>

© ISO 2007

All rights reserved. Unless otherwise specified, no part of this publication may be reproduced or utilized in any form or by any means, electronic or mechanical, including photocopying and microfilm, without permission in writing from either ISO at the address below or ISO's member body in the country of the requester.

ISO copyright office  
Case postale 56 • CH-1211 Geneva 20  
Tel. + 41 22 749 01 11  
Fax + 41 22 749 09 47  
E-mail [copyright@iso.org](mailto:copyright@iso.org)  
Web [www.iso.org](http://www.iso.org)

Published in Switzerland

## Contents

Page

Foreword.....	iv
1 Scope .....	1
2 Normative references .....	1
3 Definitions .....	1
4 Principle .....	1
5 Reagent.....	1
6 Apparatus .....	2
7 Sample .....	4
8 Procedure .....	4
9 Expression of results .....	4
10 Precision of method .....	5
11 Test report .....	5
Annex A (informative) Nitrogen-purification train.....	6

**ITeH STANDARD PREVIEW**  
**(standards.iteh.ai)**

ISO 5068-2:2007

<https://standards.iteh.ai/catalog/standards/sist/6aa6967f-7fd6-46ff-aff2-702ddf245f70/iso-5068-2-2007>

## Foreword

ISO (the International Organization for Standardization) is a worldwide federation of national standards bodies (ISO member bodies). The work of preparing International Standards is normally carried out through ISO technical committees. Each member body interested in a subject for which a technical committee has been established has the right to be represented on that committee. International organizations, governmental and non-governmental, in liaison with ISO, also take part in the work. ISO collaborates closely with the International Electrotechnical Commission (IEC) on all matters of electrotechnical standardization.

International Standards are drafted in accordance with the rules given in the ISO/IEC Directives, Part 2.

The main task of technical committees is to prepare International Standards. Draft International Standards adopted by the technical committees are circulated to the member bodies for voting. Publication as an International Standard requires approval by at least 75 % of the member bodies casting a vote.

Attention is drawn to the possibility that some of the elements of this document may be the subject of patent rights. ISO shall not be held responsible for identifying any or all such patent rights.

ISO 5068-2 was prepared by Technical Committee ISO/TC 27, *Solid mineral fuels*, Subcommittee SC 5, *Methods of analysis*.

This first edition of ISO 5068-2, together with ISO 5068-1, cancels and replaces ISO 5068:1983, which has been technically revised.

ISO 5068 consists of the following parts, under the general title *Brown coals and lignites — Determination of moisture content*:

- *Part 1: Indirect gravimetric method for total moisture*
- *Part 2: Indirect gravimetric method for moisture in the analysis sample*

iTeh STANDARD PREVIEW  
(standards.iteh.ai)

<https://standards.iteh.ai/catalog/standards/sist/6aa6967f-7fd6-46ff-aff2-702dd7245f70/iso-5068-2-2007>

# Brown coals and lignites — Determination of moisture content —

## Part 2: Indirect gravimetric method for moisture in the analysis sample

### 1 Scope

This International Standard specifies a method for the determination of the moisture content in the analysis sample of brown coals and lignites using an indirect gravimetric method.

### 2 Normative references

The following referenced documents are indispensable for the application of this document. For dated references, only the edition cited applies. For undated references, the latest edition of the referenced document (including any amendments) applies.

ISO 1213-2, *Solid mineral fuels — Vocabulary — Part 2: Terms relating to sampling, testing and analysis*

ISO 5069-2, *Brown coals and lignites — Principles of sampling — Part 2: Sample preparation for determination of moisture content and for general analysis*

### 3 Definitions

For the purpose of this document, the definitions given in ISO 1213-2 apply.

### 4 Principle

A test portion of the general analysis test sample is dried to constant mass at a temperature of 105 °C to 110 °C in an atmosphere of nitrogen. The moisture content of the analysis sample is calculated from the loss in mass of the test portion.

**NOTE** Brown coals and lignites are hygroscopic and therefore their moisture content varies with change of humidity of the atmosphere. Hence, the moisture content of the analysis sample is determined whenever test portions are weighed out for other analyses sample, for example volatile matter, calorific value, carbon and hydrogen, etc.

### 5 Reagent

**5.1 Desiccant**, fresh or freshly regenerated and preferably self-indicating.

Suitable desiccants are magnesium perchlorate and silica gel.

**WARNING — Magnesium perchlorate is a strong oxidizing agent. Do not attempt to regenerate the absorbent. Do not permit contact with organic materials or a reducing agent.**

**5.2 Nitrogen**, high-purity, dry, with a maximum oxygen content of 30 µl/l.

NOTE Commercial nitrogen of this purity is available. See Annex A for details.

## 6 Apparatus

**6.1 Oven**, capable of being controlled at a temperature of 105 °C to 110°C and with the provision for the nitrogen to pass through it at a flow rate of approximately 15 times the oven volume per hour and of lowest practical volume, i.e. minimum free space.

Before using a new oven, carry out a temperature profile through the interior and take care to insert samples only where the temperature is known to be 105° to 110°C.

A suitable oven is illustrated in Figure 1.

**iTeh STANDARD PREVIEW**  
**(standards.iteh.ai)**

[ISO 5068-2:2007](https://standards.iteh.ai/catalog/standards/sist/6aa6967f-7fd6-46ff-af2-702ddf245f70/iso-5068-2-2007)

<https://standards.iteh.ai/catalog/standards/sist/6aa6967f-7fd6-46ff-af2-702ddf245f70/iso-5068-2-2007>

Dimensions in millimetres

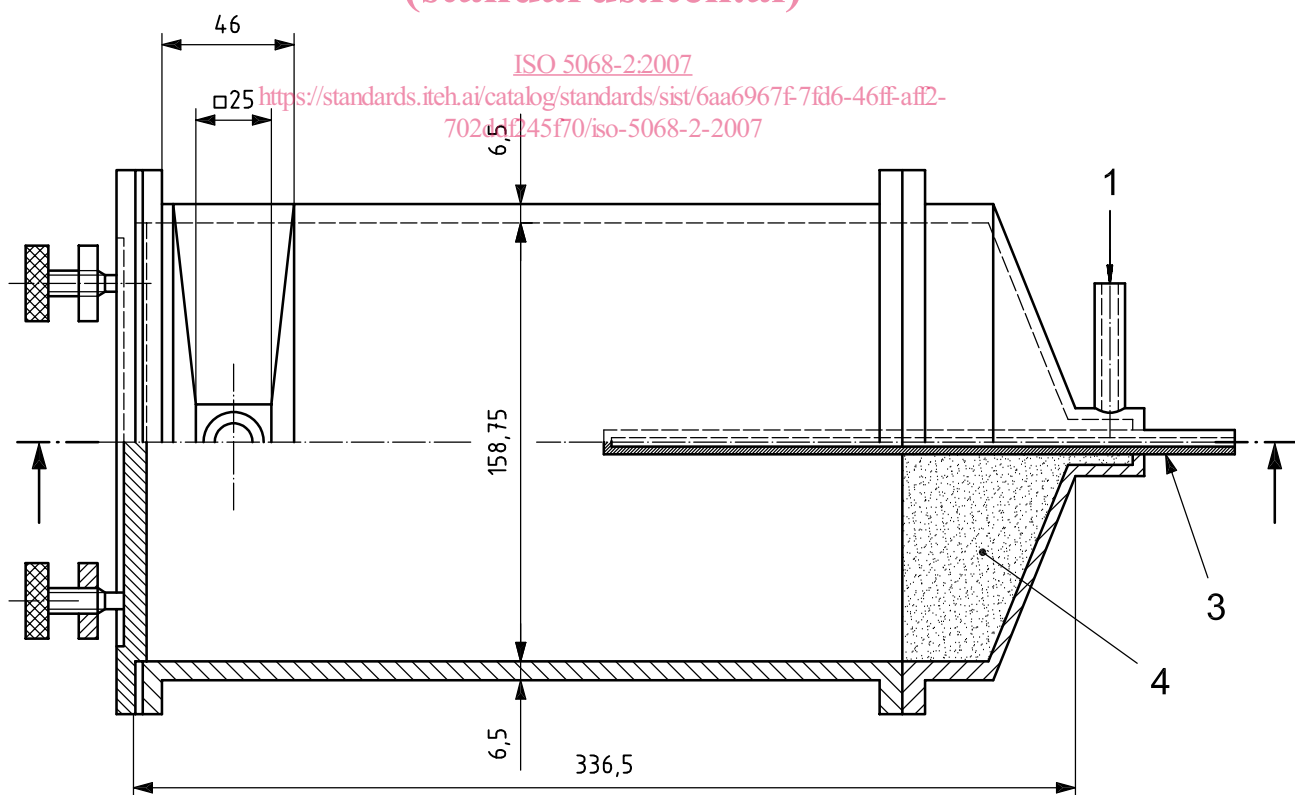
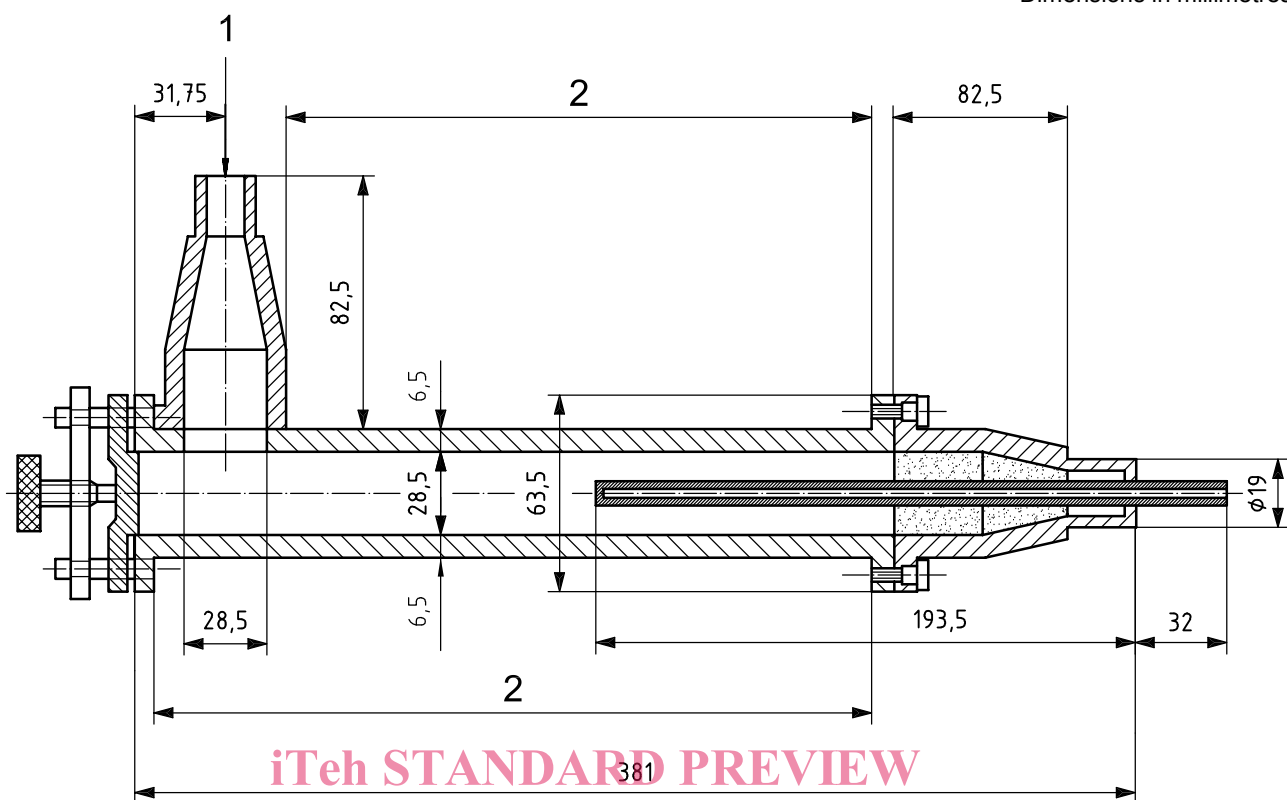

**Key**

- |                             |   |
|-----------------------------|---|
| 1 nitrogen outlet           | 3 thermometer tube                                    |
| 2 space for heating element | 4 copper gauze, having apertures of nominal size 0,25 |

**Figure 1 — Typical nitrogen oven**

**6.2 Weighing dish**, a shallow dish, of silica or glass, with ground edges and fitted with a ground-glass cover, or a non-corrodible, heat-resistant material with a well-fitting lid.

The diameter of the dish shall be such that the mass of coal layer does not exceed 0,15 g/cm<sup>2</sup> for 1 g to 2 g of the analysis sample.

**6.3 Balance**, sensitive to 0,001 g.

**6.4 Flow meter**, capable of measuring the rate of flow nitrogen through the oven.

**6.5 Drying tower**, 250 ml capacity, packed with magnesium perchlorate or silica gel for drying the nitrogen.

**6.6 Cooling vessel**, for example a desiccator without desiccant, containing a metal plate, preferably of aluminium or copper.

The vessel may be provided with a means to pass dry nitrogen through it during the cooling period.

## 7 Sample

The analysis sample is prepared in accordance with ISO 5069-2 and generally ground to pass a 0,212 mm sieve.

## 8 Procedure

Raise the temperature of the oven to between 105 °C and 110 °C while passing nitrogen through it at a rate to provide 15 oven-volume changes per hour.

Weigh a clean, dry, empty weighing dish with its lid to the nearest 0,001 g. Spread into it an even layer of 1 g to 2 g of the analysis sample (Clause 7). Cover and reweigh to the nearest 0,001 g.

Place the uncovered vessel and its lid in the oven for 3 h or until constant mass is obtained.

NOTE The time required to achieve constant mass can be assessed by individual laboratories for each coal rank.

Remove the dish with the dried sample from the oven and replace the cover immediately. If the size of the oven allows this, replace the cover while the dish is still in the oven. Allow the covered dish to cool on a thick metal plate for no longer than 5 min. Transfer the dish to a cooling vessel and allow it to cool to room temperature (approximately 20 min). As soon as the sample reaches room temperature, reweigh to the nearest 0,001 g.

## 9 Expression of results

**9.1** The moisture content,  $M_{ad}$ , of the analysis sample, expressed as a mass, is calculated using Equation (1):

$$M_{ad} = \frac{m_2 - m_3}{m_2 - m_1} \times 100 \quad (1)$$

where

$m_1$  is the mass of weighing dish and its lid, expressed in grams;

$m_2$  is the mass of weighing dish, lid and sample before heating, expressed in grams;

$m_3$  is the mass of weighing dish, lid and sample after heating, expressed in grams.

**9.2** Take as the final result of the test the arithmetic mean of the results of duplicate determinations. Report the result to the nearest 0,1 %.



## 10 Precision of method

### 10.1 Repeatability limit

The results of duplicate determinations, carried out in the same laboratory by the same operator using the same apparatus on the same sample within short intervals of time, shall not differ by more than 0,3 %.

## 11 Test report

The test report shall contain the following information:

- a) identification of the sample tested;
- b) reference of the standard used;
- c) result and the method of expression used;
- d) date of the test.

## iTeh STANDARD PREVIEW (standards.iteh.ai)

[ISO 5068-2:2007](https://standards.iteh.ai/catalog/standards/sist/6aa6967f-7fd6-46ff-af2-702ddf245f70/iso-5068-2-2007)

<https://standards.iteh.ai/catalog/standards/sist/6aa6967f-7fd6-46ff-af2-702ddf245f70/iso-5068-2-2007>