

---

---

**Resilient and laminate floor coverings —  
Determination of indentation and residual  
indentation —**

**Part 1:  
Residual indentation**

*Revêtements de sol résilients et stratifiés — Détermination du  
poinçonnement et du poinçonnement résmanent —  
Partie 1: Poinçonnement rémanent*

[ISO 24343-1:2007](https://standards.iteh.ai/catalog/standards/sist/f977581e-c22a-41ff-ab62-917dd891565e/iso-24343-1-2007)

<https://standards.iteh.ai/catalog/standards/sist/f977581e-c22a-41ff-ab62-917dd891565e/iso-24343-1-2007>



**PDF disclaimer**

This PDF file may contain embedded typefaces. In accordance with Adobe's licensing policy, this file may be printed or viewed but shall not be edited unless the typefaces which are embedded are licensed to and installed on the computer performing the editing. In downloading this file, parties accept therein the responsibility of not infringing Adobe's licensing policy. The ISO Central Secretariat accepts no liability in this area.

Adobe is a trademark of Adobe Systems Incorporated.

Details of the software products used to create this PDF file can be found in the General Info relative to the file; the PDF-creation parameters were optimized for printing. Every care has been taken to ensure that the file is suitable for use by ISO member bodies. In the unlikely event that a problem relating to it is found, please inform the Central Secretariat at the address given below.

**iTeh STANDARD PREVIEW**  
**(standards.iteh.ai)**

[ISO 24343-1:2007](https://standards.iteh.ai/catalog/standards/sist/f977581e-c22a-41ff-ab62-917dd891565e/iso-24343-1-2007)

<https://standards.iteh.ai/catalog/standards/sist/f977581e-c22a-41ff-ab62-917dd891565e/iso-24343-1-2007>



**COPYRIGHT PROTECTED DOCUMENT**

© ISO 2007

All rights reserved. Unless otherwise specified, no part of this publication may be reproduced or utilized in any form or by any means, electronic or mechanical, including photocopying and microfilm, without permission in writing from either ISO at the address below or ISO's member body in the country of the requester.

ISO copyright office  
Case postale 56 • CH-1211 Geneva 20  
Tel. + 41 22 749 01 11  
Fax + 41 22 749 09 47  
E-mail [copyright@iso.org](mailto:copyright@iso.org)  
Web [www.iso.org](http://www.iso.org)

Published in Switzerland

## Foreword

ISO (the International Organization for Standardization) is a worldwide federation of national standards bodies (ISO member bodies). The work of preparing International Standards is normally carried out through ISO technical committees. Each member body interested in a subject for which a technical committee has been established has the right to be represented on that committee. International organizations, governmental and non-governmental, in liaison with ISO, also take part in the work. ISO collaborates closely with the International Electrotechnical Commission (IEC) on all matters of electrotechnical standardization.

International Standards are drafted in accordance with the rules given in the ISO/IEC Directives, Part 2.

The main task of technical committees is to prepare International Standards. Draft International Standards adopted by the technical committees are circulated to the member bodies for voting. Publication as an International Standard requires approval by at least 75 % of the member bodies casting a vote.

Attention is drawn to the possibility that some of the elements of this document may be the subject of patent rights. ISO shall not be held responsible for identifying any or all such patent rights.

ISO 24343-1 was prepared by Technical Committee ISO/TC 219, *Floor coverings*.

ISO 24343 consists of the following parts, under the general title *Resilient and laminate floor coverings — Determination of indentation and residual indentation*:

— *Part 1: Residual indentation*

The following part is planned:

— *Part 2: Short term indentation*

[ISO 24343-1:2007](https://standards.iteh.ai/catalog/standards/sist/f977581e-c22a-41ff-ab62-917dd891565e/iso-24343-1-2007)

<https://standards.iteh.ai/catalog/standards/sist/f977581e-c22a-41ff-ab62-917dd891565e/iso-24343-1-2007>

**iTeh STANDARD PREVIEW**  
**(standards.iteh.ai)**

ISO 24343-1:2007

<https://standards.iteh.ai/catalog/standards/sist/f977581e-c22a-41ff-ab62-917dd891565e/iso-24343-1-2007>

# Resilient and laminate floor coverings — Determination of indentation and residual indentation —

## Part 1: Residual indentation

### 1 Scope

This part of ISO 24343 describes a method for determining the residual indentation produced in a resilient or laminate floor covering after the application and removal of a constant load.

### 2 Terms and definitions

For the purposes of this document, the following terms and definitions apply.

#### 2.1

##### **residual indentation**

difference between the initial thickness and the thickness measured after removal of the load

[ISO 24343-1:2007](#)

#### 2.2

##### **thickness**

distance between two parallel plates where the floor covering is inserted under a specific load

<https://standards.iteh.ai/catalog/standards/sist/f977581e-c22a-41ff-ab62-917dd891565e/iso-24343-1-2007>

### 3 Principle

A test piece is subjected to a static loading, the thickness being measured before loading and after a recovery period.

### 4 Apparatus

**4.1 Straight, steel cylindrical indenter**, of diameter  $11,30 \text{ mm} \pm 0,05 \text{ mm}$ , with the edge of the flat base slightly rounded. Area of the indenter:  $100 \text{ mm}^2$ .

**4.2 Rigid, horizontal platform**, of a minimum diameter 35 mm.

**4.3 Device**, by means of which a preliminary force of  $3,00 \text{ N} \pm 0,03 \text{ N}$  and a total force of  $500 \text{ N} \pm 0,5 \text{ N}$  (pressure 5 MPa) can be smoothly applied. The frame shall not deform by more than 0,05 mm measured in the direction of the axis under the maximum force. This deformation shall be taken into consideration when measuring indentation. (See Figure 1.)

**4.4 Comparator**, for measuring the depth of indentation to  $\pm 0,01 \text{ mm}$ .

Dimensions in millimetres

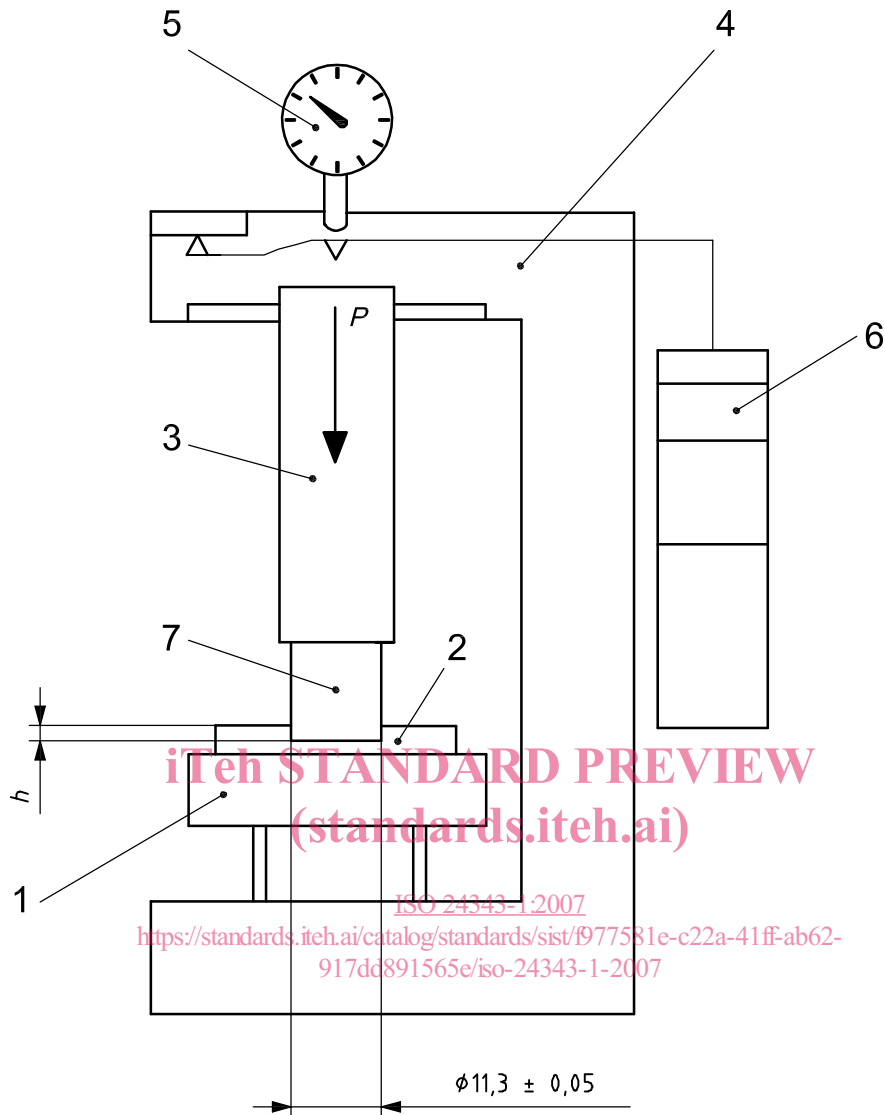

**Key**

- |                       |               |
|-----------------------|---------------|
| 1 horizontal platform | 5 comparator  |
| 2 test piece          | 6 dead weight |
| 3 annular weight      | 7 indenter    |
| 4 lever arm           |               |
- $p$  pressure (5 MPa)  
 $h$  indentation depth

**Figure 1 — Example of device to apply force on an indenter**

**4.5 Apparatus for measuring the thickness of the test piece to the nearest 0,01 mm.** Diameter of the foot:  $6,00 \text{ mm} \pm 0,03 \text{ mm}$  ( $28,3 \text{ mm}^2$ ). Mass applied:  $0,085 \text{ kg} \pm 0,003 \text{ kg}$  (approximately 30 kPa).

When the floor covering has one or more non-solid layers (e.g. foam), then a mass of  $0,028 \text{ kg} \pm 0,001 \text{ kg}$  (approximately 10 kPa) shall be applied.

**4.6 Stopwatch.**

**4.7 Annular weight,** of approximate internal diameter 25 mm and a mass of 0,5 kg.

## 5 Atmosphere for conditioning and testing

Condition the test piece at a temperature of  $(23 \pm 2)$  °C and a relative humidity of  $(50 \pm 5)$  % for a minimum of 24 h. Maintain these conditions when carrying out the test.

## 6 Sampling and selection of specimen

Take a representative sample from the available material. Take three test pieces each with dimensions of at least 60 mm × 60 mm cut from a roll or different tiles or planks.

## 7 Test procedure

**7.1** Mark the place of measurement and measure the initial thickness of the test piece,  $t_0$ , at its centre to 0,01 mm, using the appropriate mass specified in 4.5.

**7.2** Place the test piece on the platform. Place the annular weight (4.7) and the indenter (4.1) on the test piece.

**7.3** Within 5 s, apply the preliminary force specified in 4.3 and adjust the comparator to zero, taking into consideration the deformation of the frame. Gently apply the total force specified in 4.3 and start the stopwatch within 2 s.

**7.4** Record the depth of indentation after 150 min to 0,01 mm and remove the force and the test piece from the platform.

This measurement is not required in the calculation of the results, but is required in a number of product specifications.

[ISO 24343-1:2007](https://standards.iteh.ai/catalog/standards/sist/f977581e-c22a-41ff-ab62-917dd891565e/iso-24343-1-2007)

**7.5** After a further 150 min, measure the final thickness of the test piece,  $t_1$ , at the marked position, using the appropriate apparatus in 4.5.

**7.6** Repeat the test on the remaining test pieces. Calculate the mean value from the measurements taken and express the result to nearest 0,01 mm.

## 8 Calculation of results

Calculate the residual indentation,  $t_0 - t_1$ , for each specimen.

$t_0$  is the initial thickness, in millimetres, mm.

$t_1$  is the final thickness, in millimetres, mm.

## 9 Precision statement

An interlaboratory test will be conducted to determine the precision of this method.

## 10 Test report

The test report shall contain the following information:

- a) a statement that the tests were performed in accordance with this part of ISO 24343 (i.e. ISO 24343-1);
- b) complete identification of the product tested, including type, source, colour and manufacturer's reference numbers;
- c) previous history of the sample;
- d) the mean value for residual indentation;
- e) the mean value for the depth of indentation after 150 min;
- f) any deviation from this part of ISO 24343, which may have affected the results.

**iTeh STANDARD PREVIEW**  
**(standards.iteh.ai)**

[ISO 24343-1:2007](https://standards.iteh.ai/catalog/standards/sist/f977581e-c22a-41ff-ab62-917dd891565e/iso-24343-1-2007)

<https://standards.iteh.ai/catalog/standards/sist/f977581e-c22a-41ff-ab62-917dd891565e/iso-24343-1-2007>



## Bibliography

- [1] EN 433, *Resilient floor coverings — Determination of residual indentation after static loading*

**iTeh STANDARD PREVIEW**  
**(standards.iteh.ai)**

[ISO 24343-1:2007](https://standards.iteh.ai/catalog/standards/sist/f977581e-c22a-41ff-ab62-917dd891565e/iso-24343-1-2007)

<https://standards.iteh.ai/catalog/standards/sist/f977581e-c22a-41ff-ab62-917dd891565e/iso-24343-1-2007>