**Resilient floor coverings — Determination
of overall thickness**

Revêtements de sol résilients — Détermination de l'épaisseur totale

iTeh STANDARD PREVIEW
(standards.iteh.ai)

[ISO 24346:2006](https://standards.iteh.ai/catalog/standards/sist/fd462174-65dc-4243-8f16-6eb6e9894636/iso-24346-2006)

<https://standards.iteh.ai/catalog/standards/sist/fd462174-65dc-4243-8f16-6eb6e9894636/iso-24346-2006>



PDF disclaimer

This PDF file may contain embedded typefaces. In accordance with Adobe's licensing policy, this file may be printed or viewed but shall not be edited unless the typefaces which are embedded are licensed to and installed on the computer performing the editing. In downloading this file, parties accept therein the responsibility of not infringing Adobe's licensing policy. The ISO Central Secretariat accepts no liability in this area.

Adobe is a trademark of Adobe Systems Incorporated.

Details of the software products used to create this PDF file can be found in the General Info relative to the file; the PDF-creation parameters were optimized for printing. Every care has been taken to ensure that the file is suitable for use by ISO member bodies. In the unlikely event that a problem relating to it is found, please inform the Central Secretariat at the address given below.

iTeh STANDARD PREVIEW
(standards.iteh.ai)

ISO 24346:2006

<https://standards.iteh.ai/catalog/standards/sist/fd462174-65dc-4243-8f16-6eb6e9894636/iso-24346-2006>

© ISO 2006

All rights reserved. Unless otherwise specified, no part of this publication may be reproduced or utilized in any form or by any means, electronic or mechanical, including photocopying and microfilm, without permission in writing from either ISO at the address below or ISO's member body in the country of the requester.

ISO copyright office
Case postale 56 • CH-1211 Geneva 20
Tel. + 41 22 749 01 11
Fax + 41 22 749 09 47
E-mail copyright@iso.org
Web www.iso.org

Published in Switzerland

Contents

Page

Foreword.....	iv
1 Scope	1
2 Terms and definitions.....	1
3 Principle	1
4 Apparatus	1
5 Sampling and selection of specimens.....	1
5.1 Sheet material	1
5.2 Tile material	2
6 Atmosphere for conditioning and testing	2
7 Test procedure	2
7.1 Preparation	2
7.2 Calibration of apparatus	3
7.3 Determination of thickness.....	3
8 Calculation and expression of results	4
9 Precision statement.....	4
10 Test report	5
Bibliography	6

<https://standards.iteh.ai/catalog/standards/sist/fd462174-65dc-4243-8f16-6eb6e9894636/iso-24346-2006>

<https://standards.iteh.ai/catalog/standards/sist/fd462174-65dc-4243-8f16-6eb6e9894636/iso-24346-2006>

Foreword

ISO (the International Organization for Standardization) is a worldwide federation of national standards bodies (ISO member bodies). The work of preparing International Standards is normally carried out through ISO technical committees. Each member body interested in a subject for which a technical committee has been established has the right to be represented on that committee. International organizations, governmental and non-governmental, in liaison with ISO, also take part in the work. ISO collaborates closely with the International Electrotechnical Commission (IEC) on all matters of electrotechnical standardization.

International Standards are drafted in accordance with the rules given in the ISO/IEC Directives, Part 2.

The main task of technical committees is to prepare International Standards. Draft International Standards adopted by the technical committees are circulated to the member bodies for voting. Publication as an International Standard requires approval by at least 75 % of the member bodies casting a vote.

Attention is drawn to the possibility that some of the elements of this document may be the subject of patent rights. ISO shall not be held responsible for identifying any or all such patent rights.

ISO 24346 was prepared by Technical Committee ISO/TC 219, *Floor coverings*.

iTeh STANDARD PREVIEW (standards.iteh.ai)

ISO 24346:2006

<https://standards.iteh.ai/catalog/standards/sist/fd462174-65dc-4243-8f16-6eb6e9894636/iso-24346-2006>

Resilient floor coverings — Determination of overall thickness

1 Scope

This International Standard specifies a method for determining the overall thickness of resilient floor coverings.

2 Terms and definitions

For the purposes of this document, the following terms and definitions apply.

2.1

overall thickness

vertical distance between two parallel plates where a resilient floor covering is inserted under a specified load

3 Principle

iTeh STANDARD PREVIEW

The test piece is placed between two parallel plates, and the distance between them is measured, the contact pressure being adapted to suit the structure of the test piece.

ISO 24346:2006

<https://standards.iteh.ai/catalog/standards/sist/fd462174-65dc-4243-8f16-6eb6e9894636/iso-24346-2006>

4 Apparatus

4.1 Movable circular upper plate.

For various types of resilient floor covering structures, the diameter of the upper plate, the applied mass, the area and the pressure shall be in accordance with Table 1.

4.2 Fixed lower plate, at least equal to size of the upper plate and at least 15 cm².

4.3 Dial gauge, to measure the distance between the plates to an accuracy of 0,01 mm.

4.4 Weighted ring or horseshoe (500 g), to hold the perimeter of the specimen uniformly flat against the fixed lower plate.

5 Sampling and selection of specimens

5.1 Sheet material

Take two representative samples from a roll, one from each end, or from the beginning of two rolls. From each sample, cut a test piece a minimum of 100 mm across the full width of the sample (see Figure 1).

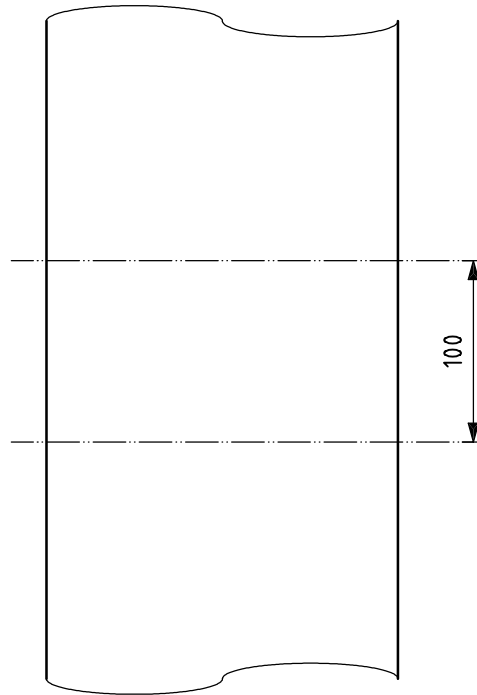

iTeh STANDARD PREVIEW

Figure 1 — Cutting sheet samples
(standards.iteh.ai)

5.2 Tile material

ISO 24346:2006

<https://standards.iteh.ai/catalog/standards/sist/fd462174-65dc-4243-8f16->

Select five tiles from carton as test pieces and cut them to the appropriate size of 50 mm × 100 mm. Where a pack or carton of tiles comprises the sample, ensure that the first and last tiles are not used as test pieces.

6 Atmosphere for conditioning and testing

Condition the specimens for a minimum of 24 h at $(23 \text{ °C} \pm 2) \text{ °C}$ and relative humidity of $(50 \pm 5) \%$ and test in the same environment.

7 Test procedure

7.1 Preparation

7.1.1 Make sure the test instrument is level.

7.1.2 Select the appropriate upper plate and force applied according to Table 1 for the test specimen type to be measured. Check that the presser foot and plates are clean.

7.1.3 Set the dial gauge to zero by allowing the presser foot to rest on the lower plate (anvil).

Table 1 — Plate and force settings

Structure of test specimen	Diameter of upper plate mm	Area mm ²	Mass applied kg	Approximate corresponding pressure kPa
Solid throughout	8,00 ± 0,05	50	0,40 ± 0,02	80
At least one non-solid layer	25,3 ± 0,1	500	0,20 ± 0,02	4
Rubber and other relief materials	50,0 ± 0,2	2 000	5,0 ± 0,1	25
Composition cork	11,30 ± 0,05	100	0,80 ± 0,02	80

7.2 Calibration of apparatus

The calibration of the gauge shall be verified by means of gauge blocks or shim stock of known thickness appropriate to the thickness being measured.

7.3 Determination of thickness

7.3.1 Place the specimen on the fixed lower plate (anvil) taking care that the specimen is flat against the anvil with the wear surface upward. Place the weighted ring or horseshoe centred to the presser foot (see Figure 2). Lower the presser foot gently until it contacts the surface of the specimen.

When measuring materials with a foam layer, select an unembossed flat area that is substantially larger, if possible, than the presser foot and at least 20 mm from any edge of the specimen. Raise the presser foot and insert the test specimen.

7.3.2 Read the thickness 5 s after application of loaded plate; read to the nearest 0,001 mm or to the measuring limits of the instrument being used. Make all measurements at least 20 mm from any edge of the specimen.

7.3.3 Unless otherwise specified, make a total of five measurements on each sample at randomly selected locations.

7.3.4 Record the measured values for each test specimen to the nearest 0,01 mm.

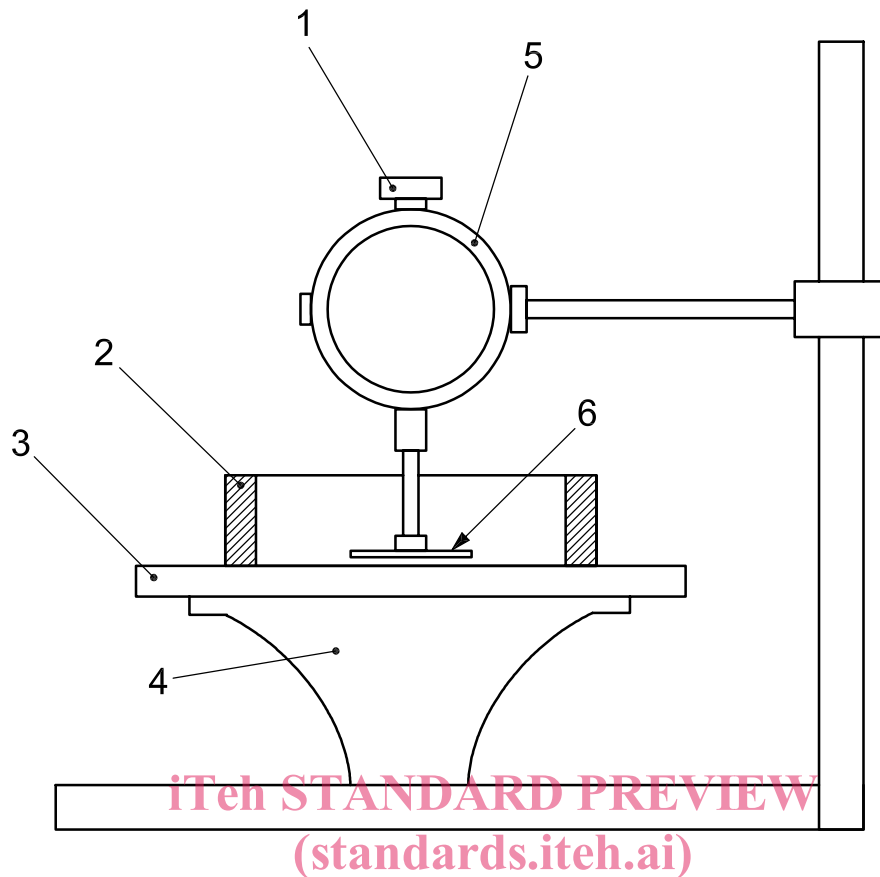

Key

- 1 mass applied
- 2 weighted ring or horseshoe
- 3 specimen
- 4 anvil, lower plate
- 5 dial gauge
- 6 upper plate

ISO 24346:2006
<https://standards.iteh.ai/catalog/standards/sist/fd462174-65dc-4243-8f16-6eb6e9894636/iso-24346-2006>

Figure 2 — Placement of weighted ring or horseshoe

8 Calculation and expression of results

Calculate the mean value of thickness from the number of measurements taken and express the result to 0,01 mm. If required by the specification, report the minimum and maximum measurements.

9 Precision statement

An interlaboratory test will be conducted to determine the precision of this method.

10 Test report

The test report shall include the following information:

- a) a statement that the tests were performed in accordance with this International Standard (ISO 24346);
- b) the complete identification of each sample, including type, source, colour and manufacturers' reference numbers;
- c) the previous history of the sample;
- d) the exact testing atmosphere at which the test was conducted (temperature and relative humidity);
- e) any deviation from this International Standard which may have affected the results;
- f) the thickness of the test specimen. This shall be the mean value for overall thickness calculated to the nearest 0,01 mm;
- g) the minimum and maximum thickness, if required.

iTeh STANDARD PREVIEW (standards.iteh.ai)

ISO 24346:2006

<https://standards.iteh.ai/catalog/standards/sist/fd462174-65dc-4243-8f16-6eb6e9894636/iso-24346-2006>