



SLOVENSKI STANDARD

SIST EN 131-1:2016

01-januar-2016

Nadomešča:

SIST EN 131-1:2007+A1:2011

Lestve - 1. del: Terminologija, tipi, funkcionalne velikosti

Ladders - Part 1: Terms, types, functional sizes

Leitern - Teil 1: Benennungen, Bauarten, Funktionsmaße

Echelles - Partie 1: Terminologie, types, dimensions fonctionnelles

iTeh STANDARD PREVIEW
(standards.iteh.ai)

Ta slovenski standard je istoveten z: EN 131-1:2015

<https://standards.iteh.ai/catalog/standards/sist/b02cd0f3-a69c-4f2d-a79e-7eb06705d920/sist-en-131-1-2016>

ICS:

01.040.97	Oprema za dom in trgovino. Razvedrilo. Šport (Slovarji)	Domestic and commercial equipment. Entertainment. Sports (Vocabularies)
97.145	Lestve	Ladders

SIST EN 131-1:2016

en,fr,de

iTeh STANDARD PREVIEW
(standards.iteh.ai)

SIST EN 131-1:2016

<https://standards.iteh.ai/catalog/standards/sist/b02cd0f3-a69c-4f2d-a79e-7eb06705d920/sist-en-131-1-2016>

EUROPEAN STANDARD
NORME EUROPÉENNE
EUROPÄISCHE NORM

EN 131-1

November 2015

ICS 01.040.97; 97.145

Supersedes EN 131-1:2007+A1:2011

English Version

Ladders - Part 1: Terms, types, functional sizes

Échelles - Partie 1: Terminologie, types, dimensions
fonctionnelles

Leitern - Teil 1: Benennungen, Bauarten,
Funktionsmaße

This European Standard was approved by CEN on 11 September 2015.

CEN members are bound to comply with the CEN/CENELEC Internal Regulations which stipulate the conditions for giving this European Standard the status of a national standard without any alteration. Up-to-date lists and bibliographical references concerning such national standards may be obtained on application to the CEN-CENELEC Management Centre or to any CEN member.

This European Standard exists in three official versions (English, French, German). A version in any other language made by translation under the responsibility of a CEN member into its own language and notified to the CEN-CENELEC Management Centre has the same status as the official versions.

CEN members are the national standards bodies of Austria, Belgium, Bulgaria, Croatia, Cyprus, Czech Republic, Denmark, Estonia, Finland, Former Yugoslav Republic of Macedonia, France, Germany, Greece, Hungary, Iceland, Ireland, Italy, Latvia, Lithuania, Luxembourg, Malta, Netherlands, Norway, Poland, Portugal, Romania, Slovakia, Slovenia, Spain, Sweden, Switzerland, Turkey and United Kingdom.

[SIST EN 131-1:2016](https://standards.iteh.ai/catalog/standards/sist/b02cd0f3-a69c-4f2d-a79e-7eb06705d920/sist-en-131-1-2016)

<https://standards.iteh.ai/catalog/standards/sist/b02cd0f3-a69c-4f2d-a79e-7eb06705d920/sist-en-131-1-2016>



EUROPEAN COMMITTEE FOR STANDARDIZATION
COMITÉ EUROPÉEN DE NORMALISATION
EUROPÄISCHES KOMITEE FÜR NORMUNG

CEN-CENELEC Management Centre: Avenue Marnix 17, B-1000 Brussels

Contents

Page

European foreword.....	3
1 Scope	4
2 Normative references	4
3 Terms and definitions	4
4 Functional sizes	13
4.1 General.....	13
4.2 Leaning rung ladders.....	13
4.2.1 General.....	13
4.2.2 One-piece leaning rung ladders.....	14
4.2.3 Sectional ladders.....	15
4.2.4 Extending ladders.....	15
4.3 Standing rung ladders.....	17
4.4 Combination ladders.....	18
4.4.1 General.....	18
4.4.2 Two-piece combination ladder.....	18
4.4.3 Three-piece combination ladder.....	20
4.5 Leaning step ladders.....	21
4.6 Standing step ladders.....	22
4.7 Standing rung and step ladder.....	24
Annex A (informative) A-deviations.....	25
Bibliography.....	26

European foreword

This document (EN 131-1:2015) has been prepared by Technical Committee CEN/TC 93 “Ladders”, the secretariat of which is held by DIN.

This European Standard shall be given the status of a national standard, either by publication of an identical text or by endorsement, at the latest by May 2016, and conflicting national standards shall be withdrawn at the latest by November 2016.

Attention is drawn to the possibility that some of the elements of this document may be the subject of patent rights. CEN [and/or CENELEC] shall not be held responsible for identifying any or all such patent rights.

This document supersedes EN 131-1:2007+A1:2011.

This document has been prepared under a mandate given to CEN by the European Commission and the European Free Trade Association.

Compared to EN 131-1:2007+A1:2011, the following modifications have been made in order to improve the stability of ladders in use:

- a) in figures stabilizers or wider base width for leaning ladders were introduced;
- b) further terms 3.48, 3.49 and 3.50 for stabilizers were added in Clause 3;
- c) requirements for minimum base width for leaning ladders were specified in 4.2.1, Table 2 and Table 6.

EN 131, *Ladders*, is one of a series about ladders:

- *Part 1: Terms, types, functional sizes* [the present document];
- *Part 2: Requirements, testing, marking*;
- *Part 3: User Instructions*;
- *Part 4: Single or multiple hinge-joint ladders*;
- *Part 6: Telescopic ladders*;
- *Part 7: Mobile ladders with platform*.

The standards of this series are listed in Clause 2 and in the Bibliography.

According to the CEN/CENELEC Internal Regulations, the national standards organizations of the following countries are bound to implement this European Standard: Austria, Belgium, Bulgaria, Croatia, Cyprus, Czech Republic, Denmark, Estonia, Finland, Former Yugoslav Republic of Macedonia, France, Germany, Greece, Hungary, Iceland, Ireland, Italy, Latvia, Lithuania, Luxembourg, Malta, Netherlands, Norway, Poland, Portugal, Romania, Slovakia, Slovenia, Spain, Sweden, Switzerland, Turkey and the United Kingdom.

EN 131-1:2015 (E)**1 Scope**

This European Standard defines terms and specifies the general design characteristics of ladders.

It applies to portable ladders.

It does not apply to ladders designed for specific professional use such as fire brigade ladders, roof ladders and mobile ladders.

NOTE 1 For multiple hinge joint ladders EN 131-4 applies.

NOTE 2 For telescopic ladders EN 131-6 applies.

NOTE 3 For mobile ladders with platforms EN 131-7 applies.

NOTE 4 This standard does not apply to step stools for which EN 14183 applies.

2 Normative references

The following documents, in whole or in part, are normatively referenced in this document and are indispensable for its application. For dated references, only the edition cited applies. For undated references, the latest edition of the referenced document (including any amendments) applies.

EN 131-2, *Ladders — Part 2: Requirements, testing, marking*

EN 131-3, *Ladders — Part 3: User Instructions*

EN 131-4:2007, *Ladders — Part 4: Single or multiple hinge-joint ladders*

<https://standards.iteh.ai/catalog/standards/sist/b02cd0f3-a69c-4f2d-a79e-7eb06705d920/sist-en-131-1-2016>

3 Terms and definitions

For the purpose of this document, the terms and definitions given in EN 131-4:2007 for single or multiple hinge-joint ladders and the following apply.

Table 1

Dimensions in millimetres

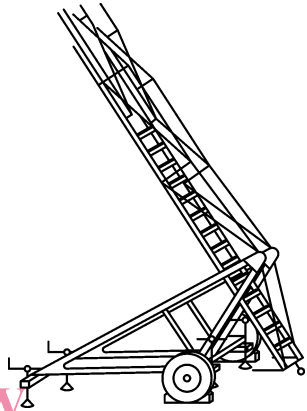
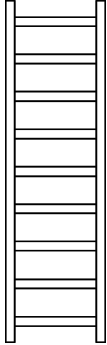
No	Terms	Definition	Figure
3.1	ladder	device incorporating steps or rungs on which a person may step to ascend or descend	
3.2	portable ladder	ladder which can be transported and set up by hand	
3.3	mobile ladder	ladder which is brought to each operational place by means of mobile support	 <p data-bbox="1198 1025 1305 1059">Figure 1</p>
3.4	rung ladder	portable ladder with rungs, which have a standing surface from front to back of less than 80 mm	
3.5	leaning rung ladder	rung ladder which does not have its own support	
3.6	one-piece leaning rung ladder	leaning rung ladder consisting of one part only	 <p data-bbox="1209 1659 1316 1693">Figure 2</p>

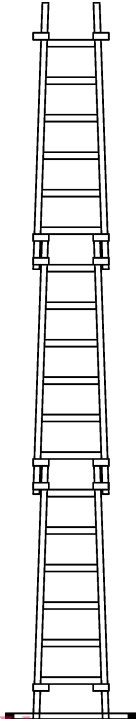
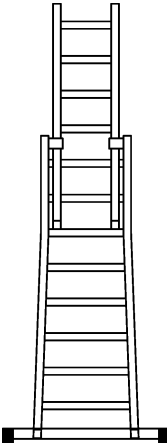
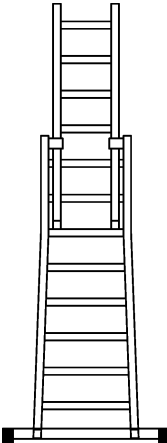
No	Terms	Definition	Figure
3.7	sectional ladder	<p>leaning ladder consisting of several sections that can be fitted together by means of connection devices</p> <p>Note 1 to entry: The length can only be varied by one whole section at a time.</p>	 <p style="text-align: center;">Figure 3</p>
3.8	extending ladder	<p>leaning rung ladder consisting of two or more parts where the length can be regulated by one rung at a time</p>	 <p style="text-align: center;">Figure 4</p>
3.9	push-up ladder extending ladder	<p>extending ladder where the upper parts are extended by hand</p>	 <p style="text-align: center;">Figure 4</p>

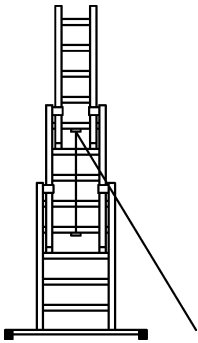
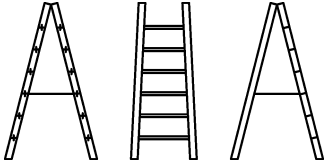
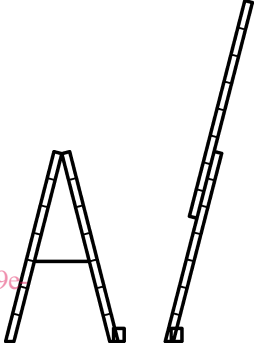
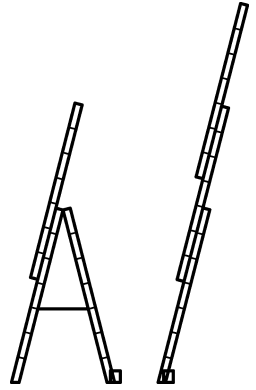
No	Terms	Definition	Figure
3.10	rope-operated extending ladder	extending ladder where the upper parts are extended by means of a rope or other means such as chains, straps or cables	 <p data-bbox="1198 633 1310 663">Figure 5</p>
3.11	standing rung ladder	two-piece self-supporting rung ladder, unilaterally or bilaterally ascendable	 <p data-bbox="1198 857 1310 887">Figure 6</p>
3.12	combination ladder	rung ladder of several parts, that can be used as, an extending ladder, a standing ladder or as a standing ladder with an extending ladder at the top, and parts of which may be used as one piece leaning ladders	 <p data-bbox="1198 1261 1310 1290">Figure 7</p>  <p data-bbox="1198 1709 1310 1738">Figure 8</p>
3.13	step ladder	portable ladder with steps horizontal during use and a standing surface from front to back equal to or greater than 80 mm	

iTeh STANDARD PREVIEW
(standards info)

SIST EN 131-1:2016
<https://standards.iteh.ai/catalog/standards/sist/b02cd0f3-a69c-4f2d-a79e-7eb06705d920/sist-en-131-1-2016>

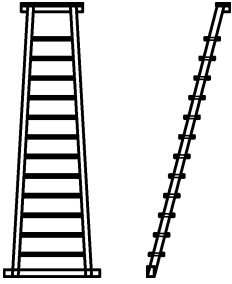
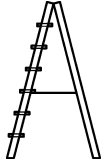
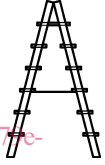
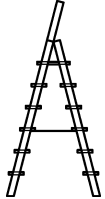
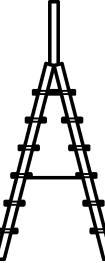
No	Terms	Definition	Figure
3.14	leaning step ladder	step ladder that does not have its own support consisting of one or several parts	 <p data-bbox="1110 573 1214 607">Figure 9</p>
3.15	standing step ladder	two-legged self-supporting step ladder, unilaterally or bilaterally ascendable; with or without platform; with or without hand-/knee rail; a platform is regarded as a step	
	unilaterally ascendable step ladder		 <p data-bbox="1110 999 1222 1032">Figure 10</p>
	bilaterally ascendable step ladder		 <p data-bbox="1110 1220 1222 1254">Figure 11</p>
	unilaterally ascendable step ladder with platform and hand-/knee rail		 <p data-bbox="1110 1476 1222 1509">Figure 12</p>
	bilaterally ascendable step ladder with platform and hand-/knee rail		 <p data-bbox="1110 1800 1222 1834">Figure 13</p>
3.16	standing ladder	ladder (with rungs or steps) which has its own support	
3.17	standing rung and step ladder	standing ladder, one section with rungs and the other section with steps	

iTeH STANDARD PREVIEW
(standards.iteh.ai)

SIST EN 131-1:2016
<https://standards.iteh.ai/catalog/standards/sist/b02cd0f3-a69c-4f2d-a77e-7eb06705d920/sist-en-131-1-2016>

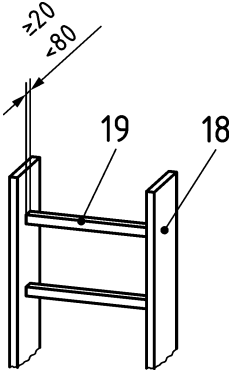
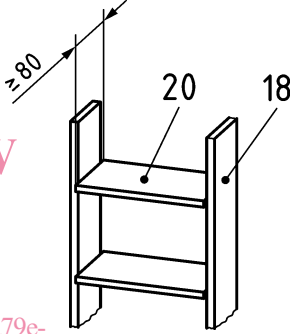
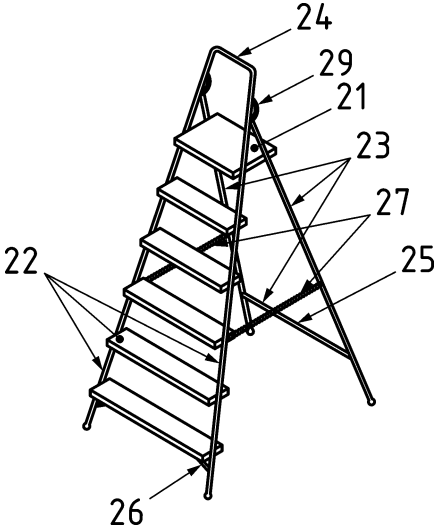
No	Terms	Definition	Figure
3.18	stile	lateral part of a ladder which supports the rungs or steps as well as cross struts of supporting legs	
3.19	rung	climbing support with a standing surface from front to back of less than 80 mm and at least 20 mm	 <p data-bbox="1193 808 1315 837">Figure 14</p>
3.20	step	climbing support with a standing surface from front to back equal to or greater than 80 mm	 <p data-bbox="1193 1202 1315 1232">Figure 15</p>
3.21	platform	topmost standing surface of a standing step ladder which is different from a step	
3.22	ascending leg	leg of a ladder with climbing supports	
3.23	supporting leg	leg of a ladder without climbing supports	
3.24	hand-/knee rail	device for holding onto or gaining support from at the upper end of a standing ladder	
3.25	cross strut	horizontal connection of the stiles of the supporting leg	
3.26	bottom brace	device which secures the lower end of the stile against buckling	
3.27	opening restraint device	device on standing ladders which secures the two legs of the ladder from sliding apart	
3.28	locking device	device to keep ladder hooks engaged on the rung or step during use	 <p data-bbox="1193 1892 1315 1921">Figure 16</p>

iTeh STANDARD PREVIEW
(standards.iteh.ai)

SIST EN 131-1:2016

<https://standards.iteh.ai/catalog/standards/sist/b02cd0f3-a69c-4f2d-a79e-7eb06705d920/sist-en-131-1-2016>