**Textiles — Determination of dimensional
change of fabrics — Accelerated machine
method**

*Textiles — Détermination des variations dimensionnelles des étoffes —
Méthode machine accélérée*

iTeh STANDARD PREVIEW
(standards.iteh.ai)

[ISO 23231:2008](https://standards.iteh.ai/catalog/standards/sist/7bfd507-0cb8-40ca-b290-a61e95c190c0/iso-23231-2008)

[https://standards.iteh.ai/catalog/standards/sist/7bfd507-0cb8-40ca-b290-
a61e95c190c0/iso-23231-2008](https://standards.iteh.ai/catalog/standards/sist/7bfd507-0cb8-40ca-b290-a61e95c190c0/iso-23231-2008)



PDF disclaimer

This PDF file may contain embedded typefaces. In accordance with Adobe's licensing policy, this file may be printed or viewed but shall not be edited unless the typefaces which are embedded are licensed to and installed on the computer performing the editing. In downloading this file, parties accept therein the responsibility of not infringing Adobe's licensing policy. The ISO Central Secretariat accepts no liability in this area.

Adobe is a trademark of Adobe Systems Incorporated.

Details of the software products used to create this PDF file can be found in the General Info relative to the file; the PDF-creation parameters were optimized for printing. Every care has been taken to ensure that the file is suitable for use by ISO member bodies. In the unlikely event that a problem relating to it is found, please inform the Central Secretariat at the address given below.

iTeh STANDARD PREVIEW
(standards.iteh.ai)

ISO 23231:2008

<https://standards.iteh.ai/catalog/standards/sist/7bfd507-0cb8-40ca-b290-a61e95c190c0/iso-23231-2008>



COPYRIGHT PROTECTED DOCUMENT

© ISO 2008

All rights reserved. Unless otherwise specified, no part of this publication may be reproduced or utilized in any form or by any means, electronic or mechanical, including photocopying and microfilm, without permission in writing from either ISO at the address below or ISO's member body in the country of the requester.

ISO copyright office
Case postale 56 • CH-1211 Geneva 20
Tel. + 41 22 749 01 11
Fax + 41 22 749 09 47
E-mail copyright@iso.org
Web www.iso.org

Published in Switzerland

Contents

Page

Foreword.....	iv
Introduction	v
1 Scope	1
2 Normative references	1
3 Terms and definitions.....	1
4 Principle	2
5 Uses and limitations	2
6 Apparatus and materials	2
7 Sampling.....	3
8 Specimens	3
9 Conditioning.....	5
10 Procedure	5
11 Measurement.....	5
12 Calculation.....	6
13 Test report	6
Annex A (informative) Interlaboratory study results.....	7
Bibliography	8

Foreword

ISO (the International Organization for Standardization) is a worldwide federation of national standards bodies (ISO member bodies). The work of preparing International Standards is normally carried out through ISO technical committees. Each member body interested in a subject for which a technical committee has been established has the right to be represented on that committee. International organizations, governmental and non-governmental, in liaison with ISO, also take part in the work. ISO collaborates closely with the International Electrotechnical Commission (IEC) on all matters of electrotechnical standardization.

International Standards are drafted in accordance with the rules given in the ISO/IEC Directives, Part 2.

The main task of technical committees is to prepare International Standards. Draft International Standards adopted by the technical committees are circulated to the member bodies for voting. Publication as an International Standard requires approval by at least 75 % of the member bodies casting a vote.

ISO 23231 was prepared by Technical Committee ISO/TC 38, *Textiles*, Subcommittee SC 2, *Cleansing, finishing and water resistance tests*.

iTeh STANDARD PREVIEW (standards.iteh.ai)

ISO 23231:2008

<https://standards.iteh.ai/catalog/standards/sist/7bfd507-0cb8-40ca-b290-a61e95c190c0/iso-23231-2008>

Introduction

The International Organization for Standardization (ISO) draws attention to the fact that it is claimed that compliance with this document may involve the use of a patent concerning the apparatus given in 6.1 and shown in Figure 1.

ISO takes no position concerning the evidence, validity and scope of this patent right.

The holder of this patent right has assured ISO that he is willing to negotiate licences under reasonable and non-discriminatory terms and conditions with applicants throughout the world. In this respect, the statement of the holder of this patent right is registered with ISO. Information may be obtained from:

SDL Atlas LLC
3934 Airway Drive
Rock Hill, South Carolina 29732
USA

Tel.: +1-803-329-2110
Email: info@sdlatlas.com
Website: www.sdlatlas.com

Attention is drawn to the possibility that some of the elements of this document may be the subject of patent rights other than those identified above. ISO shall not be held responsible for identifying any or all such patent rights.

iTeh STANDARD PREVIEW
(standards.iteh.ai)
ISO 23231:2008
<https://standards.iteh.ai/catalog/standards/sist/7bfd507-0cb8-40ca-b290-a61e95c190c0/iso-23231-2008>

iTeh STANDARD PREVIEW
(standards.iteh.ai)

ISO 23231:2008

<https://standards.iteh.ai/catalog/standards/sist/7bfd507-0cb8-40ca-b290-a61e95c190c0/iso-23231-2008>

Textiles — Determination of dimensional change of fabrics — Accelerated machine method

1 Scope

1.1 This International Standard specifies a test method for an accelerated procedure for determination of the dimensional change of fabrics which will then be made into garments or other end-use articles that will be laundered in a variety of settings. The procedure uses an apparatus with programmable settings that simulate multiple domestic or industrial laundering actions as well as wet processing operations in fabric manufacturing. This method is less suitable for heavy, tightly woven fabrics, such as denim, and fabrics with water-repellent finish. This method and the apparatus are not to be used to develop care labels.

1.2 While this International Standard is intended to measure the same dimensional property as in ISO 5077, its application is as an accelerated test for use in a production environment. It is not unusual for different test methods to exist for determining the same property. Examples are methods for abrasion, for pilling, and for colour fastness to light.

iTeh STANDARD PREVIEW

2 Normative references (standards.iteh.ai)

The following referenced documents are indispensable for the application of this document. For dated references, only the edition cited applies. For undated references, the latest edition of the referenced document (including any amendments) applies.

ISO 6330, *Textiles — Domestic washing and drying procedures for textile testing*

3 Terms and definitions

For the purposes of this document, the following terms and definitions apply.

3.1

dimensional change

generic term for changes in length or width of a fabric specimen subjected to specified conditions

NOTE The change is usually expressed as a percentage of the initial dimension of a specimen.

3.2

growth

(of textile materials) dimensional change resulting in an increase of length or width of a specimen

3.3

laundering

(of textile materials) process intended to remove soils and/or stains by treatment (washing) with an aqueous detergent solution and normally including subsequent rinsing, extracting, and drying

3.4

shrinkage

(of textile materials) dimensional change resulting in a decrease in the length or width of a specimen

4 Principle

This is an accelerated method for ascertaining the relaxation and shrinkage behaviour of textile fabrics and textile products. A sample is submitted separately to a short complete washing cycle in a whirling hot washing bath and to a few short complete treatment cycles in a whirling hot water bath, each cycle being finished by a short hydroextraction of the sample and drying in a hot air stream. The method is performed during incessant movement of the yarns at cross-over points and flexing of the yarns in the textile structure of the sample. Dimensional changes are determined by comparing the distances between length and width direction benchmarks before and after a programmed test cycle.

5 Uses and limitations

5.1 Although data have been generated comparing the dimensional change of some textile materials after home laundering and when using this accelerated apparatus, the user will find it necessary to determine the correlation between the results from a selected programme for this apparatus and the dimensional change results from other chosen test methods or wet processes.

5.2 Dimensional changes exhibited by articles produced from textile fabrics are primarily (but not entirely) dependent on dimensional changes exhibited by the fabrics.

5.3 While the term "laundering" includes the use of an aqueous detergent solution, this accelerated method does not use detergents.

6 Apparatus and materials

6.1 Apparatus for performing the method, comprising a vertical perforated drum (1) containing radially arranged partitions (2) dividing the drum into two or more chambers and rotatable in two directions, arranged in a heat-insulated protective casing (3), covered by a lid (4), a means which can give the drum alternately a rotational motion or an oscillating motion, an air heater (5) connected over inlets (6) to the inside of the casing (3), above each chamber, and a water heater (7) connected to the casing via a water inlet and outlet pipe (8). (See Figure 1.)¹⁾

6.2 Indelible ink marking pen²⁾, selected with the smallest tip.

6.3 Tape or ruler, marked in millimetres.

6.4 For 255 mm benchmarks, a **tape or ruler template** from which percent dimensional change to 0,5 % or a smaller increment can be read directly²⁾.

1) An apparatus as described in 6.1 is manufactured commercially as the Quickwash Plus® and is available from SDL Atlas LLC, 3934 Airway Drive, Rock Hill, South Carolina 29732, USA, Tel: +1-803-329-2110; Email: info@sdlatlas.com. This information is given for the convenience of users of this document and does not constitute an endorsement by ISO of this product.

2) Marking pens are available from Mark-Tex Corp., 805 East Old 56th Hwy, Olathe, KS 66061 (+1-800-323-9536; www.dymon.com), and AATCC, P.O. Box 12215, Research Triangle Park, NC 27709, Tel: +1-919-549-8141; Fax: +1-919-549-8933; orders@aatcc.org. Measuring rulers are available from AATCC. This information is given for the convenience of users of this document and does not constitute an endorsement by ISO of these products.

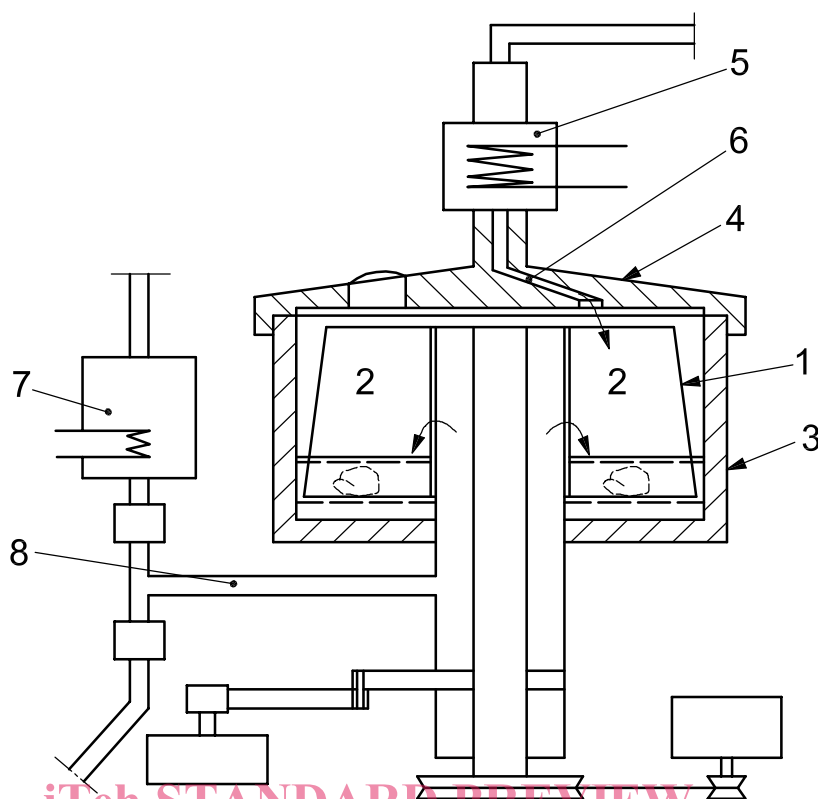

Key

- 1 perforated drum
- 2 partition
- 3 casing
- 4 lid

(standards.iteh.ai)

5 air heater

6 inlet

7 water heater

8 outlet pipe

<https://standards.iteh.ai/catalog/standards/sist/7bfb507-0cb8-40ca-b290-a1e0c0e0-23231-2008>

Figure 1 — Example of accelerated laundering apparatus

7 Sampling

7.1 A minimum of four specimens with different lengthwise and widthwise yarns in each specimen shall be taken from each sample.

7.2 An additional number of specimens from a sample may be taken to increase the precision of the test results.

8 Specimens

8.1 Cut specimens parallel to the lengthwise fabric direction as shown in Figure 2 a). Diagonal alignment of specimens may be selected to minimize the need for over-edging specimens and to obtain larger benchmark dimensions [see Figure 2 b)].

8.2 The size of specimens may depend upon the model of the apparatus and the type, number, and configuration of its basket chambers.

Specimens, 190 mm × 190 mm, shall be aligned with the fabric length and width directions and marked with (125 ± 1) mm benchmark distances. Alternatively, 255 mm × 255 mm specimens, may be marked diagonally to accommodate (255 ± 1) mm benchmark distances that are aligned with the actual length and width directions of the fabric [see Figure 2 b)].