



Standard Specification for Joints for IPS PVC Pipe Using Solvent Cement¹

This standard is issued under the fixed designation D 2672; the number immediately following the designation indicates the year of original adoption or, in the case of revision, the year of last revision. A number in parentheses indicates the year of last reapproval. A superscript epsilon (ϵ) indicates an editorial change since the last revision or reapproval.

This standard has been approved for use by agencies of the Department of Defense.

1. Scope

1.1 This specification covers the socket produced for solvent cement joints on both pressure and non-pressure IPS pipe. It also covers the testing of the joints on both pressure and non-pressure pipe, and includes requirements for socket dimensions, burst pressure, and joint tightness tests of the solvent cemented joints. The tests described are not intended for routine quality control, but rather to evaluate the performance characteristics of the joint.

NOTE 1—On dual marked Schedule 40 DWV and potable water pipe, the socket bells must conform to the dimensional and physical requirements for pressure socket bells.

1.2 The text of this specification references notes, footnotes, and appendixes which provide explanatory material. These notes and footnotes (excluding those in tables and figures) shall not be considered as requirements of the specification.

1.3 The values stated in inch-pound units are to be regarded as the standard. The values given in parentheses are for information only.

NOTE 2—Changes in ground, water, or air temperature will produce expansion or contraction forces in PVC piping, and these will result in longitudinal shear stresses in the solvent cement joints. These stresses must be considered in the design and operation of the system.

NOTE 3—See Practice D 618 for information relating to this specification.

1.4 The following safety hazards caveat pertains only to the test method portion, Section 10, of this specification. *This standard does not purport to address all of the safety concerns, if any, associated with its use. It is the responsibility of the user of this standard to establish appropriate safety and health practices and determine the applicability of regulatory limitations prior to use.*

2. Referenced Documents

2.1 ASTM Standards:

- D 618 Practice for Conditioning Plastics for Testing²
- D 1599 Test Method for Short-Time Hydraulic Failure Pressure of Plastic Pipe, Tubing, and Fittings³
- D 1600 Terminology for Abbreviated Terms Relating to Plastics²
- D 1785 Specification for Poly(Vinyl Chloride) (PVC) Plastic Pipe, Schedules 40, 80, and 120³
- D 2122 Test Method for Determining Dimensions of Thermoplastic Pipe and Fittings³
- D 2241 Specification for Poly(Vinyl Chloride) (PVC) Pressure-Rated Pipe (SDR Series)³
- D 2564 Specification for Solvent Cements for Poly(Vinyl Chloride) (PVC) Plastic Piping Systems³
- D 2665 Specification for Poly(Vinyl Chloride) (PVC) Plastic Drain, Waste and Vent Pipe and Fittings³
- D 2855 Practice for Making Solvent-Cemented Joints with Poly(Vinyl Chloride) (PVC) Pipe and Fittings³
- F 412 Terminology Relating to Plastic Piping Systems³
- F 512 Specification for Smooth-Wall Poly(Vinyl Chloride) (PVC) Conduit and Fittings for Underground Installation³
- F 656 Specification for Primers for Use in Solvent Cement Joints of Poly(Vinyl Chloride) (PVC) Plastic Pipe and Fittings³

2.2 NSF Standard:

Standard No. 14 for Plastic Piping Components and Related Materials⁴

3. Terminology

3.1 Definitions—Definitions are in accordance with Terminology F 412 and abbreviations are in accordance with Terminology D 1600, unless otherwise specified.

4. Materials

4.1 *General*—PVC plastics used to make the pipe, which are belled under this specification, are designated in PVC product standards referencing this standard.

4.2 Solvent cements must conform to the requirements of Specification D 2564.

¹ This specification is under the jurisdiction of ASTM Committee F-17 on Plastic Piping Systems and is the direct responsibility of Subcommittee F17.20 on Joining.

Current edition approved Sept. 10, 1996. Published November 1996. Originally published as D 2672 – 68. Last previous edition D 2672 – 96.

² *Annual Book of ASTM Standards*, Vol 08.01.

³ *Annual Book of ASTM Standards*, Vol 08.04.

⁴ Available from the National Sanitation Foundation, P.O. Box 1468, Ann Arbor, MI 48106.

4.3 Primers must conform to the requirements of Specification F 656.

5. Requirements

5.1 *Bell Socket Dimensions and Tolerances:*

5.1.1 *Diameters and Length*—The diameter, lengths, and tolerances of the bell sockets shall be as shown in Table 1 when measured in accordance with Test Method D 2122.

5.1.2 *Wall Thicknesses*—The minimum wall thicknesses of the sockets (bell) shall not be less than 90 % of the minimums shown for the pressure pipe in the applicable ASTM specification. For non-pressure pipe, the integral socket (bell) shall be considered satisfactory when formed from pipe which meets the minimum wall thickness requirements of the applicable ASTM specification when measured in accordance with Test Method D 2122.

5.2 *Joint Tests:*

5.2.1 *Burst Pressure*—The minimum burst pressures for pipe and (bell) socket on pressure pipe shall be as given for pressure pipe in the applicable ASTM specification when

determined in accordance with 10.3.

5.2.2 *Joint Tightness*—The (bell) socket joint on non-pressure pipe shall not leak when tested in accordance with 10.4.

6. Workmanship

6.1 Each socket (bell) is required to be uniform in depth, circular in cross section concentric with the pipe, and to have an end as square as commercially practicable.

7. Retest and Rejection

7.1 If the results of any test(s) do not meet the requirements of this specification, the test(s) shall be conducted again only by agreement between the purchaser and the seller. Under such agreement, minimum requirements shall not be lowered, nor tests omitted, substituted, changed, or modified, nor shall specification limits be changed. If upon retest, failure occurs, the quantity of product represented by the test(s) does not meet the requirements of this specification.

TABLE 1 Tapered Sockets for Bell-End Pipe, in. (mm)

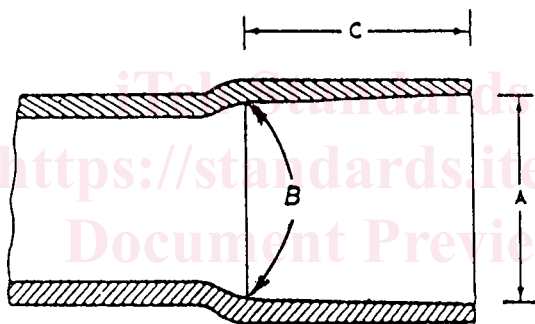

Pipe Size, in.	A Socket Entrance Diameter, in. (mm)			B Socket Bottom Diameter, in. (mm)			C Socket Length, in. (mm), min ^A	
	Nominal Diameter	Tolerance on Nominal Diameter	Maximum Out-of- Round ^B	Nominal Diameter	Tolerance on Nominal Diameter	Maximum Out-of- Round ^B	Pressure	Non-Pre- sure ^C
1/8	0.417 (10.59)	±0.004 (±0.10)	0.024 (0.61)	0.401 (10.18)	±0.004 (±0.10)	0.024 (0.61)	0.500 (12.70)	...
1/4	0.552 (14.02)	±0.004 (±0.10)	0.024 (0.61)	0.536 (13.61)	±0.004 (±0.10)	0.024 (0.61)	0.500 (12.70)	...
3/8	0.687 (17.45)	±0.004 (±0.10)	0.024 (0.61)	0.671 (17.04)	±0.004 (±0.10)	0.024 (0.61)	0.750 (19.05)	...
1/2	0.848 (21.54)	±0.004 (±0.10)	0.024 (0.61)	0.836 (21.23)	±0.004 (±0.10)	0.024 (0.61)	1.000 (25.40)	1.000 (25.40)
3/4	1.058 (26.87)	±0.004 (±0.10)	0.028 (0.71)	1.046 (26.57)	±0.004 (±0.10)	0.028 (0.71)	1.250 (31.75)	1.000 (25.40)
1	1.325 (33.65)	±0.005 (±0.13)	0.030 (0.76)	1.310 (33.27)	±0.005 (±0.13)	0.030 (0.76)	1.500 (38.10)	1.000 (25.40)
1 1/4	1.670 (42.42)	±0.005 (±0.13)	0.034 (0.86)	1.655 (42.04)	±0.005 (±0.13)	0.034 (0.86)	1.750 (44.45)	1.250 (31.75)
1 1/2	1.912 (48.56)	±0.006 (±0.15)	0.036 (0.91)	1.894 (48.11)	±0.006 (±0.15)	0.036 (0.91)	2.000 (50.80)	1.375 (34.92)
2	2.387 (60.63)	±0.006 (±0.15)	0.036 (0.91)	2.363 (60.02)	±0.006 (±0.15)	0.036 (0.91)	2.250 (57.15)	1.750 (44.45)
2 1/2	2.889 (73.38)	±0.007 (±0.18)	0.044 (1.12)	2.861 (72.67)	±0.007 (±0.18)	0.044 (1.12)	2.500 (63.50)	2.000 (50.80)
3	3.516 (89.31)	±0.008 (±0.20)	0.046 (1.17)	3.484 (88.49)	±0.008 (±0.20)	0.046 (1.17)	3.250 (82.55)	2.875 (73.02)
3 1/2	4.016 (102.01)	±0.008 (±0.20)	0.046 (1.17)	3.984 (101.19)	±0.008 (±0.20)	0.046 (1.17)	3.500 (88.90)	3.125 (79.37)
4	4.518 (114.76)	±0.009 (±0.23)	0.048 (1.22)	4.482 (113.84)	±0.009 (±0.23)	0.048 (1.22)	4.000 (101.60)	3.375 (85.72)
5	5.583 (141.81)	±0.010 (±0.25)	0.080 (2.03)	5.543 (140.79)	±0.010 (±0.25)	0.080 (2.03)	4.000 (101.60)	4.000 (101.60)
6	6.647 (168.83)	±0.011 (±0.28)	0.082 (2.08)	6.603 (167.72)	±0.011 (±0.28)	0.082 (2.08)	6.000 (152.40)	5.000 (127.00)
8	8.655 (219.84)	±0.015 (±0.38)	0.120 (3.05)	8.598 (218.39)	±0.015 (±0.38)	0.120 (3.05)	6.000 (152.40)	5.000 (127.00)
10	10.776 (273.71)	±0.015 (±0.38)	0.130 (3.30)	10.722 (272.34)	±0.015 (±0.38)	0.130 (3.30)	7.500 (190.50)	6.500 (165.10)
12	12.778 (324.56)	±0.015 (±0.38)	0.150 (3.81)	12.721 (323.11)	±0.015 (±0.38)	0.150 (3.81)	8.500 (215.90)	7.500 (190.50)
14	14.035 (356.49)	±0.015 (±0.38)	0.150 (3.81)	13.985 (355.22)	±0.015 (±0.38)	0.150 (3.81)	9.000 (228.60)	8.000 (203.20)
16	16.045 (410.08)	±0.015 (±0.38)	0.160 (4.06)	15.980 (405.89)	±0.015 (±0.38)	0.160 (4.06)	10.000 (254.00)	9.000 (228.60)
18	18.055 (458.60)	±0.020 (±0.51)	0.180 (4.57)	17.980 (456.69)	±0.020 (±0.51)	0.180 (4.57)	12.000 (304.80)	10.000 (254.00)
20	20.065 (509.65)	±0.025 (±0.64)	0.200 (5.08)	19.980 (507.49)	±0.025 (±0.64)	0.200 (5.08)	12.000 (304.80)	11.000 (279.40)
24	24.075 (611.51)	±0.030 (±0.76)	0.240 (6.10)	23.970 (608.84)	±0.030 (±0.76)	0.240 (6.10)	12.000 (304.80)	12.000 (304.80)

^AAll tolerances on minimum dimensions shall be on the plus side.

^B"Out-of-round" is defined as the maximum measured diameter less the minimum measured diameter.

^CMaximum length = +0.250 in. (6.350 mm).