



Designation: E1444 – 05

## Standard Practice for Magnetic Particle Testing<sup>1</sup>

This standard is issued under the fixed designation E1444; the number immediately following the designation indicates the year of original adoption or, in the case of revision, the year of last revision. A number in parentheses indicates the year of last reapproval. A superscript epsilon ( $\epsilon$ ) indicates an editorial change since the last revision or reapproval.

*This standard has been approved for use by agencies of the Department of Defense.*

### 1. Scope

1.1 This practice establishes minimum requirements for magnetic particle examination used for the detection of surface or slightly subsurface discontinuities in ferromagnetic material. Guide E709 can be used in conjunction with this practice as a tutorial.

NOTE 1—This Practice replaces MIL-STD-1949.

1.2 The magnetic particle examination method is used to detect cracks, laps, seams, inclusions, and other discontinuities on or near the surface of ferromagnetic materials. Magnetic particle examination may be applied to raw material, billets, finished and semi-finished materials, welds, and in-service parts. Magnetic particle examination is not applicable to non-ferromagnetic metals and alloys such as austenitic stainless steels. See Appendix X6 for additional information.

1.3 All areas of this Practice may be open to agreement between the Cognizant Engineering Organization and the supplier, or specific direction from the Cognizant Engineering Organization.

1.4 *This standard does not purport to address all of the safety concerns, if any, associated with its use. It is the responsibility of the user of this standard to establish appropriate safety and health practices and determine the applicability of regulatory limitations prior to use.*

### 2. Referenced Documents

2.1 The following documents form a part of this standard practice to the extent specified herein.

2.2 *ASTM Standards:*<sup>2</sup>

[A275/A275M Practice for Magnetic Particle Examination of Steel Forgings](#)

[A456/A456M Specification for Magnetic Particle Examination of Large Crankshaft Forgings](#)

[D1966 Test Method for Foots in Raw Linseed Oil \(Gravimetric Method\)](#)<sup>3</sup>

[E543 Specification for Agencies Performing Nondestructive Testing](#)

[E709 Guide for Magnetic Particle Testing](#)

[E1316 Terminology for Nondestructive Examinations](#)

2.3 *ASNT Documents:*<sup>4</sup>

[SNT-TC-1A Recommended Practice No. "Personnel Qualification and Certification in Nondestructive Testing"](#)

[ANSI/ASNT CP-189 Standard for Qualification and Certification of NDT Personnel](#)

2.4 *Society of Automotive Engineers (SAE)-AMS Documents:*<sup>5,6</sup>

[AMS 2641 Magnetic Particle Inspection Vehicle](#)

[AMS 3040 Magnetic Particles, Nonfluorescent, Dry Method](#)

[AMS 3041 Magnetic Particles, Nonfluorescent, Wet Method, Oil Vehicle, Ready-To-Use](#)

[AMS 3042 Magnetic Particles, Nonfluorescent, Wet Method, Dry Powder](#)

[AMS 3043 Magnetic Particles, Nonfluorescent, Wet Method, Oil Vehicle, Aerosol Packaged](#)

[AMS 3044 Magnetic Particles, Fluorescent, Wet Method, Dry Powder](#)

[AMS 3045 Magnetic Particles, Fluorescent, Wet Method, Oil Vehicle, Ready-To-Use](#)

[AMS 3046 Magnetic Particles, Fluorescent, Wet Method, Oil Vehicle, Aerosol Packaged](#)<sup>6</sup>

[AMS 5062 Steel, Low Carbon Bars, Forgings, Tubing, Sheet, Strip, and Plate 0.25 Carbon, Maximum](#)

[AMS 5355 Investment Castings](#)

[AMS I-83387 Inspection Process, Magnetic Rubber](#)

[AS 4792 Water Conditioning Agents for Aqueous Magnetic Particle Inspection](#)

<sup>1</sup> This practice is under the jurisdiction of ASTM Committee E07 on Nondestructive Testing and is the direct responsibility of Subcommittee E07.03 on Liquid Penetrant and Magnetic Particle Methods.

Current edition approved March 1, 2005. Published June 2005. Originally approved in 1991. Last previous edition approved in 2001 as E1444 - 01. DOI: 10.1520/E1444-05.

<sup>2</sup> For referenced ASTM standards, visit the ASTM website, www.astm.org, or contact ASTM Customer Service at service@astm.org. For *Annual Book of ASTM Standards* volume information, refer to the standard's Document Summary page on the ASTM website.

<sup>3</sup> Withdrawn. The last approved version of this historical standard is referenced on www.astm.org.

<sup>4</sup> Available from American Society for Nondestructive Testing, 1711 Arlingate Plaza, P.O. Box 28518, Columbus, OH 43228-0518.

<sup>5</sup> Copies of standards, specifications, drawings, and publications required by manufacturers in connection with specification acquisition should be obtained from the contracting activity or as directed by the contracting officer.

<sup>6</sup> Available from Society of Automotive Engineers (SAE), 400 Commonwealth Dr., Warrendale, PA 15096-0001.

**AS 5282** Tool Steel Ring Standard for Magnetic Particle Inspection

**AS 5371** Reference Standards Notched Shims for Magnetic Particle Inspection

2.5 *Federal Standards*:<sup>5,7</sup>

**FED-STD-313** Material Safety Data Sheets, Preparation and the Submission of

**FED-STD-595** Colors

2.6 *Military Standards*:<sup>5,7</sup>

**MIL-STD-1907** Inspection, Liquid Penetrant and Magnetic Particle Soundness Requirements for Materials, Parts, and Weldments

**MIL-STD-2175** Castings, Classification and Inspection of **A-A-59230** Fluid, Magnetic Particle Inspection, Suspension

2.7 *OSHA Document*:<sup>8</sup>

**29 CFR** 1910.1200 Hazard Communication

2.8 *ANSI Document*:<sup>5,9</sup>

**ANSI/NCSL Z 540-1** General Requirement for Calibration Laboratories and Measuring Test Equipment

2.9 *ISO Document*:

**ISO 10012-1** Quality Assurance Requirements for Measuring Equipment<sup>10</sup>

2.10 *AIA Document*:

**NAS 410** Certification and Qualification of Nondestructive Test Personnel<sup>11</sup>

2.11 *DoD Contracts*—Unless otherwise specified, the editions of the documents that are DoD adopted are those listed in the issue of the DoDISS (Department of Defense Index of Specifications and Standards) cited in the solicitation.

2.12 *Order of Precedence*—In the event of conflict between the text of this practice and the referenced documents cited herein, the text of this practice takes precedence.

### 3. Terminology

3.1 *Definitions*—The definitions relating to magnetic particle examination, which appear in Terminology **E1316**, shall apply to the terms used in this practice.

3.2 *Definitions of Terms Specific to This Standard*:

3.2.1 *Cognizant Engineering Organization*—The company, agency, or other authority responsible for the system or component for which magnetic particle examination is required. This, in addition to design personnel, may include personnel from material and process engineering, stress analysis, NDT or quality groups and others as appropriate.

### 4. Significance and Use

4.1 *Description of Process*—Magnetic particle examination consists of magnetizing the area to be examined, applying

suitably prepared magnetic particles while the area is magnetized, and subsequently interpreting and evaluating any resulting particle accumulations. Maximum detectability occurs when the discontinuity is positioned on the surface and perpendicular to the magnetic flux.

4.2 This practice establishes the basic parameters for controlling the application of the magnetic particle method. This practice is written so that it can be specified on the engineering drawing, specification, or contract. It is not a detailed how-to procedure to be used by the inspector and, therefore, must be supplemented by a detailed written procedure that conforms to the requirements of this practice.

### 5. General Practice

5.1 *Acceptance Requirements*—The acceptance requirements applicable to the part or group of parts shall be incorporated as part of the written procedure either specifically or by reference to other applicable documents, such as **MIL-STD-1907**, containing the necessary information. When parts are zoned, the acceptance criteria for each zone shall be specified. Methods for establishing acceptance requirements for large crankshaft forgings are covered in Specification **A456/A456M**. Methods for establishing requirements for steel forgings are covered in Test Method **A275/A275M**. Methods for classifying metal castings are given in **MIL-STD-2175** and **AMS 5355**.

5.1.1 *Aircraft-Quality Steel Cleanliness*—The examination of aircraft-quality steel for cleanliness using magnetic particle examination shall be as appropriate to the type of steel being inspected. However, inspection of parts fabricated from this material shall be in accordance with the requirements of this practice.

5.2 *Personnel Qualification*—Personnel performing examinations in accordance with this practice shall be qualified in accordance with ASNT Recommended Practice No. **SNT-TC-1A**, ANSI/ASNT Standard CP-189, **NAS 410**, or as specified in the contract or purchase order.

5.3 *Agency Qualification*—If specified in the contractual agreement, NDT agencies shall be qualified and evaluated as described in **E543**. The applicable edition of **E543** shall be specified in the contractual agreement.

5.4 *Written Procedure*—Magnetic particle examination shall be performed in accordance with a written procedure applicable to the part or group of parts under examination. The procedure shall be in accordance with the requirements of this Practice. The process, when conducted in accordance with the written procedure, shall be capable of detecting the rejectable discontinuities specified in the acceptance criteria. The written procedure may be general if it clearly applies to all of the specified parts being examined and meets the requirements of this practice. All written procedures, including technique sheets for specific parts, shall be approved by an individual qualified and certified at Level III for magnetic particle examination in accordance with the requirements of 5.2. Procedures shall be submitted to the Cognizant Engineering Organization for review, or approval, or both, when requested.

5.4.1 *Elements of the Written Procedure*—The written procedure shall include at least the following elements, either directly or by reference to the applicable documents:

<sup>7</sup> Available from Standardization Documents Order Desk, DODSSP, Bldg. 4, Section D, 700 Robbins Ave., Philadelphia, PA 19111-5098

<sup>8</sup> Available from U.S. Government Printing Office Superintendent of Documents, 732 N. Capitol St., NW, Mail Stop: SDE, Washington, DC 20401.

<sup>9</sup> Available from National Conference of Standards Laboratories, 1800 30th St. Suite 305b, Boulder, CO. 80301.

<sup>10</sup> Available from International Organization for Standardization, Case Postale 56, Geneva, Switzerland.

<sup>11</sup> Available from Aerospace Industries Association of America, Inc. (AIA), 1250 Eye St., NW, Washington, DC 20005.

**TABLE 1 Required Verification Intervals**

Item	Maximum Time Between Verification <sup>A</sup>
<b>Lighting:<sup>B</sup></b>	
Visible light intensity (5.7.1.1)	weekly
Ambient light intensity (5.7.1.2)	weekly
Black light intensity (5.7.2, 7.3.5)	daily
System Performance: <sup>B</sup> (7.1, 7.1.1, 7.1.2)	daily
Wet particle concentration (7.2.1.1)	8 hours, or every shift change
Wet particle contamination: <sup>B</sup> (7.2.1.2)	1 week
Water break test (7.2.2)	daily
<b>Equipment calibration check:<sup>B</sup></b>	
Ammeter accuracy (7.3.1)	6 months
Timer control (7.3.2)	6 months
Quick break (7.3.3)	6 months
Yoke dead weight check (7.3.4)	6 months
Black and white light meters	6 months
Gaussmeter accuracy	6 months

<sup>A</sup> When the inspection system is in operation.

<sup>B</sup> The maximum time between verifications may be reduced or extended when substantiated by actual technical/reliability data.

5.4.1.1 Procedure identification number and the date it was written;

5.4.1.2 Identification of the part(s) to which the procedure applies; this shall include the material and alloy;

5.4.1.3 Sequence of magnetic particle examination as related to manufacturing process operation, if applicable;

5.4.1.4 Identification of test parts used for system performance verification (see 7.1.1 and 7.1.2);

5.4.1.5 Areas of the part to be examined (include an illustration, either a drawing or photo);

5.4.1.6 Part preparation required before examination;

5.4.1.7 Directions for positioning the item with respect to the magnetizing equipment;

5.4.1.8 The type of magnetizing current and the equipment to be used;

5.4.1.9 Method of establishing the magnetization (head, coil, prods, yoke, cable wrap, etc.);

5.4.1.10 Directions of magnetization to be used, the order in which they are applied, and any demagnetization procedures to be used between shots;

5.4.1.11 The current level, or the number of ampere turns, to be used and the duration of its application;

5.4.1.12 Type of magnetic particle material (dry or wet, visible or fluorescent, etc.) to be used and the method and equipment to be used for its application and, for the case of wet particles, the particle concentration limits;

5.4.1.13 Type of records and method of marking parts after examination;

5.4.1.14 Acceptance requirements, to be used for evaluating indications and disposition of parts after evaluation; and

5.4.1.15 Post-examination demagnetization and cleaning requirements.

5.5 *Examination Sequence*—Perform magnetic particle examination after all operations which might cause or reveal discontinuities. Such operations include, but are not limited to, forging, heat treating, electroplating, forming, welding, grinding, straightening, machining, and proof loading.

5.5.1 Perform magnetic particle examination prior to shot peening (to provide a beneficial compressive layer) and prior to applying protective finishes such as priming, painting, plating (see 6.1.2 through 6.1.4.5) or other coatings.

5.5.2 In-process examinations may not be substituted for final examination.

5.6 *Record of Examination*—The results of all magnetic particle examinations shall be recorded. Records shall provide for traceability to the specific part or lot examined, serial number if serialized, and they shall identify the NDE contractor or facility and the procedures used in the examination, the lot size, and the number of parts accepted. All recorded results shall be identified, filed, and made available for review by the contracting agency upon request.

### 5.7 Lighting:

5.7.1 *Visible Light*—Conduct visible light intensity measurements upon initial light installation or when changes occur that would cause the light intensity to change and at the intervals specified in Table 1.

5.7.1.1 Visible light shall be used when examining with nonfluorescent magnetic particles and for interpretation of indications found with fluorescent magnetic particles. A minimum light intensity of 100 fc (1000 lx) shall be available at the surface of the part undergoing examination or evaluation.

5.7.1.2 *Ambient Visible Light*—Fluorescent magnetic particle examinations shall be performed in a darkened area with a maximum ambient visible light level of 2 fc (20 lx) measured at the part surface.

5.7.2 *Black Lights*—Inspection black lights shall meet the requirements of 7.3.5. The minimum acceptable intensity is 1000  $\mu\text{W}/\text{cm}^2$  (10  $\text{W}/\text{m}^2$ ) at the surface being examined. Black lights shall be checked periodically for cleanliness and integrity and shall be cleaned, repaired or replaced as appropriate. Periodic checks of cleanliness/integrity need not be recorded.

5.7.3 *Restricted Area Examination*—Where lamps are physically too large to directly illuminate the examination surface, special lighting, such as UV pencil lights or UV light guides or borescopes shall be used. The image viewed must have sufficient resolution to effectively evaluate the required discontinuities. Light intensity shall be measured at the expected working distance and shall meet the requirements of 5.7.1.1 and 5.7.2 as appropriate.

### 5.8 Materials:

5.8.1 *Dry Particle Requirements*—Dry particles shall meet the requirements of AMS 3040.

5.8.2 *Wet Particle Requirements*—Wet particles shall meet the requirements of AMS 3041, 3042, 3043, 3044, 3045, or 3046, as applicable.

5.8.3 *Suspension Vehicles*—The suspension vehicle for the wet method shall be a light petroleum distillate conforming to AMS 2641 (Type I) or DoD-F-87935, or a suitably conditioned water that conforms to the requirements of 5.8.4. When approved by the contracting agency, AMS 2641 (Type II) may be used. When specified, the oil suspension vehicle shall meet the salient characteristics specified in A-A-59230.

5.8.4 *Conditioned Water Vehicle*—When water is used as a suspension vehicle for magnetic particles, the conditioning agents used shall comply with AS 4792. Proper wetting shall be determined by a water break test (see 7.2.2). Smoother

surfaces generally require a greater percent of wetting agent than rough surfaces. Foaming of the bath must be minimized to the point that it does not interfere with the inspection process.

5.8.4.1 *Water Vehicle Conditioning Agents*—Any agents added to the water vehicle for any purpose shall conform to the requirements of the particle manufacturer.

5.8.5 *Particle Concentration*—The concentration of particles in the suspension bath shall be as specified in the written procedure. Particle concentrations outside of the range of 0.1 to 0.4 mL in a 100-mL bath sample for fluorescent particles and 1.2 to 2.4 mL in a 100 mL sample for nonfluorescent particles shall not be used. Fluorescent particles and nonfluorescent particles shall not be used together.

**6. Specific Practice**

6.1 *Preparation of Parts for Examination:*

6.1.1 *Preinspection Demagnetization*—The part shall be demagnetized before examination if prior operations have produced a residual magnetic field that may interfere with the examination.

6.1.2 *Surface Cleanliness and Finish*—The surface of the part to be examined shall be essentially smooth, clean, dry, and free of oil, scale, machining marks, or other contaminants or conditions that might interfere with the efficiency of the examination.

6.1.3 *Plugging and Masking*—Plugging and masking is required when specified by the Cognizant Engineering Organization.

6.1.4 *Plating and Coatings*—Examine parts which will receive either a plating or coating as follows:

6.1.4.1 Examination is required prior to all non-electroplated coatings.

6.1.4.2 Electroplated surfaces with a final plating thickness of 0.0008 in. [0.02 mm] or less shall be examined either before or after electroplating, or grinding, or both, of electroplated surfaces.

6.1.4.3 Electroplated surfaces with a final plating thickness of between 0.0008 in. [0.02 mm] and 0.0050 in. [0.13 mm] shall be examined both before and after electroplating, or grinding, or both, of electroplated surfaces.

(1) Electroplated surfaces with a final plating thickness of 0.0050 in. [0.13 mm] or greater shall be examined before electroplating, or grinding, or both, of electroplated surfaces.

(2) Magnetic particle examination after electroplating is not required for steels with a tensile strength less than or equal to 160 ksi.

6.1.4.4 Use caution when examining parts with an electroplated nickel coating as indications may form in the nickel plating itself.

6.1.4.5 For in-service examination, plating or coatings do not require removal prior to examination unless they are damaged or they interfere with the examination process.

6.2 *Magnetization Methods:*

6.2.1 *Types of Magnetizing Current*—The types of currents used for magnetic particle examination are full-wave rectified alternating (FWDC) current (1 or 3 phase), half-wave rectified alternating (HWDC) current, and alternating (AC) current. The equipment used shall fulfill the magnetizing and demagnetizing requirements adequately, as outlined herein, without damage to

the part under examination, and they shall include the necessary features required for safe operation.

6.2.2 *Permanent Magnets*—Permanent magnets are not to be used for magnetic particle examination unless specifically authorized by the Cognizant Engineering Organization. When permanent magnets are used, adequate magnetic field strength shall be established in accordance with 7.3.4.

6.2.3 *Yokes*—When using yokes (electromagnetic probes) for magnetic particle examination, adequate magnetic field strength shall be established in accordance with 7.3.4.

6.2.4 *Magnetizing Current Application*—Alternating current is to be used only for the detection of defects open to the surface. Full-wave rectified alternating current has the deepest possible penetration and must be used for inspection for defects below the surface when using the wet magnetic particle method. Half-wave rectified alternating current is advantageous for the dry powder method because it creates a pulsating unidirectional field that gives increased mobility to the particles.

6.2.5 *Magnetic Field Directions*—Discontinuities are difficult to detect by the magnetic particle method when they make an angle less than 45° to the direction of magnetization. To ensure the detection of discontinuities in any direction, each part must be magnetized in a minimum of two directions at approximately right angles to each other. Depending on part geometry, this may consist of circular magnetization in two or more directions, multiple circular and longitudinal magnetization, or of longitudinal magnetization in two or more directions. The pie gage as illustrated in Fig. 1 or the flexible laminated strips as described in Annex A2 may only be used as a tool to demonstrate the direction of the external magnetic field. Exceptions necessitated by part geometry, size, or other factors require specific approval of the Cognizant Engineering Organization.

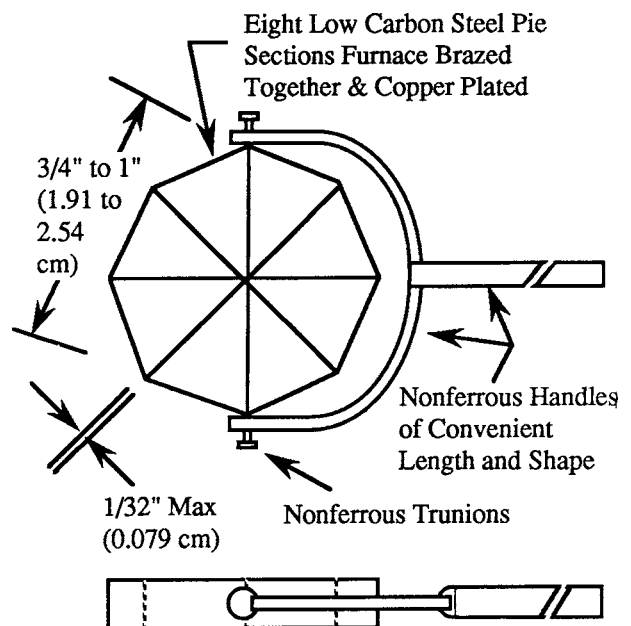

FIG. 1 Pie-field Indicator for Use in Magnetic Particle Examination

6.2.6 *Multidirectional Magnetization*—Multidirectional magnetization may be used to fulfill the requirement for magnetization in two directions if it is demonstrated that it is effective in all areas. Test parts in accordance with 6.3.1.1 or shims manufactured to the requirements of AS 5371, or as otherwise approved by the Cognizant Engineering Organization, shall be used to verify field direction, strength, and balance in multidirectional magnetization. Balance of the field intensity is critical. The field intensity shall be balanced in all directions. The particle application must be timed so that the magnetization levels reach full value in all directions while the particles are mobile on the surface under examination.

6.2.7 *Direct Magnetization*—Direct magnetization is accomplished by passing current directly through the part under examination. Electrical contact is made to the part using head and tail stock, prods, clamps, magnetic leeches, or by other means. Caution shall be taken to ensure that the electrical current is not flowing while contacts are being applied or removed and that excessive heating does not occur in the contact area. Unless otherwise specified by the Cognizant Engineering Organization, prods shall not be used for the examination of aerospace components (flight hardware) or on finished surfaces.

6.2.8 *Indirect Magnetization*—Indirect part magnetization uses pre-formed coils, cable wraps, yokes, field (flux) flow fixtures, or a central conductor to induce a magnetic field in a part when no electrical contact is made.

6.2.9 *Induced Current Magnetization*—Induced current magnetization (toroidal or circumferential field) is accomplished by inductively coupling a part to an electrical coil to create a suitable current flow in the part as illustrated in Fig. 2. This method is often advantageous on ring-shaped parts with a central aperture and with an *L/D* ratio less than three, especially where the elimination of arcing or burning is of vital importance.

6.2.10 *Parallel Current Induced Magnetization*—This method of magnetization may occur when a ferromagnetic part

is placed alongside and parallel to a current-carrying conductor. A magnetic field will be induced in the part that is more transverse than circular. This type of magnetization shall not be used for magnetic particle examination unless approved by the CEO.

6.2.11 *Magnetization of Aerospace Lifting Hardware*—The use of permanent magnets, electromagnetic yokes, coil wraps or prods on aerospace lifting hardware must be approved by the Cognizant Engineering Organization.

6.3 *Magnetic Field Strength:*

6.3.1 *Magnetic Field Strength*—The applied magnetic field shall have sufficient strength to produce satisfactory indications, but it must not be so strong that it causes the masking of relevant indications by nonrelevant accumulations of magnetic particles. Adequate magnetic field strength may be determined by one or a combination of the following methods:

6.3.1.1 By examining parts having known or artificial discontinuities of the type, size, and location specified in the acceptance requirements or by using the notched shims as defined in Annex A1;

6.3.1.2 By using a Hall effect probe gaussmeter capable of measuring the peak values of the tangential field as described in Appendix X4; and

6.3.1.3 By using the current levels specified in 6.3.4 or 6.3.5 or the formulas given in Appendix X5. These current levels and formulas provide only a rough guide and shall only be used in conjunction with either 6.3.1.1, or 6.3.1.2, or CEO approval, or a combination thereof.

6.3.2 Tangential-field strengths shall have a minimum value of 30 Gauss ( $30 \times 10^{-4}$  Tesla [T]) when measured at the part surface using a Hall effect probe gaussmeter as described in Appendix X4. Ensure that adequate field strengths are present in the areas of the part to be examined.

6.3.3 *Magnetization Current Levels*—The current values given in 6.3.4 and 6.3.5 are average current values and are applied directly to full-wave rectified current. For other types

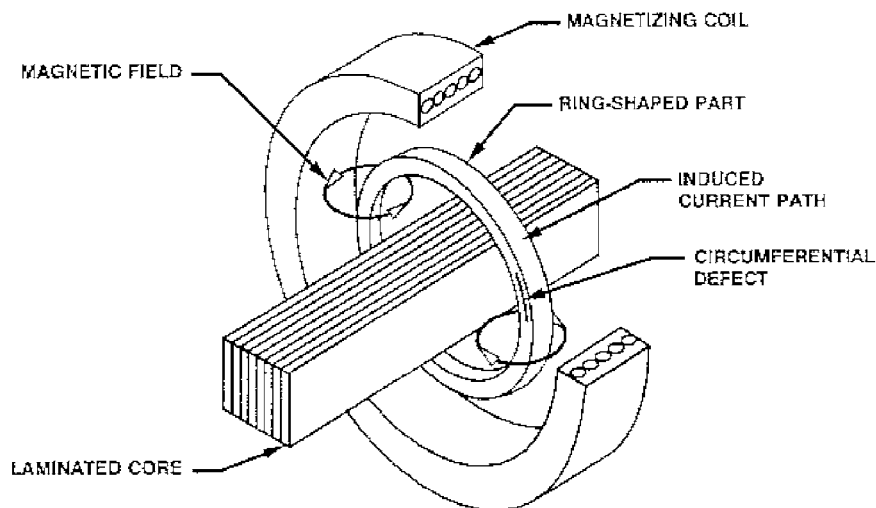

When the magnetic field in the magnetizing coil suddenly collapses, an eddy current will be generated in the ring-shaped part. The eddy current produces a resultant toroidal field that may be used to detect circumferential discontinuities in the part.

FIG. 2 Example of Induced Current Magnetization

of current, the operator's manual the equipment manufacturer, or the CEO should be consulted.

**6.3.4 Prod Current Levels**—When using prods on material  $\frac{3}{4}$  in. [19 mm] in thickness or less, 90 to 115 A/in. of prod spacing [3.5 to 4.5 A/mm] shall be used. For material greater than  $\frac{3}{4}$  in. [19 mm] in thickness, 100 to 125 A/in. of prod spacing [4.0 to 5.0 A/mm] shall be used. Prod spacing shall not be less than 2 in. [50 mm] or greater than 8 in. [200 mm]. The effective width of the magnetizing field when using prods is one fourth of the prod spacing on each side of a line through the prod centers.

**6.3.5 Direct Circular Magnetization**— When magnetizing by passing current directly through the part the nominal current shall be 300 to 800 A/in. of part diameter [12 to 32 A/mm]. The diameter of the part shall be taken as the greatest distance between any two points on the outside circumference of the part. Currents will normally be 500 A/in. [20 A/mm] or lower, with the higher currents up to 800 A/in. [32 A/mm] being used to examine for inclusions or to examine low-permeability alloys such as precipitation-hardened steels. Amperages of less than 300 A/in. may be used when part configuration dictates and approval is obtained from the Level III and the Cognizant Engineering Organization.

**6.3.6 Central Conductor Circular Magnetization**—Circular magnetization may be provided by passing current through a conductor that is positioned inside the part. In this case, alternating current is to be used only when the sole purpose of the test is to examine for surface discontinuities on the inside surface of the part. If only the inside of the part is to be examined, the diameter shall be the greatest distance between two points, 180 degrees apart on the inside circumference. Otherwise, the diameter is determined as in 6.3.5.

**6.3.6.1 Centrally Located Conductor**—When the axis of the central conductor is located near the central axis of the part, the same current levels as given in 6.3.5 shall apply.

**6.3.6.2 Offset Central Conductor**—When the conductor that is positioned inside the part is placed against an inside wall of the part, the current levels as given in 6.3.5 shall apply, except that the total diameter shall be the sum of the diameter of the central conductor plus twice the wall thickness of the part. The distance along the part circumference (interior) that may be effectively examined shall be taken as approximately four times the diameter of the central conductor up to 360 degrees provided the presence of suitable fields is verified. The entire circumference shall be examined by rotating the part on the conductor, allowing for approximately a 10 % magnetic field overlap. See Fig. 3 for an illustration.

**6.3.7 Longitudinal Magnetization Using Coils**—Longitudinal magnetization is often accomplished by passing current through a coil encircling the part, or section of the part, to be examined (that is, by using a coil shot). This produces a magnetic field parallel to the axis of the coil. The effective field extends a distance on either side of the coil center approximately equal to the radius of the coil. The actual effective distance must be demonstrated based on the particular part to be examined. For parts longer than these effective distances, the entire length shall be examined by repositioning the part within the coil, allowing for approximately 10 % effective

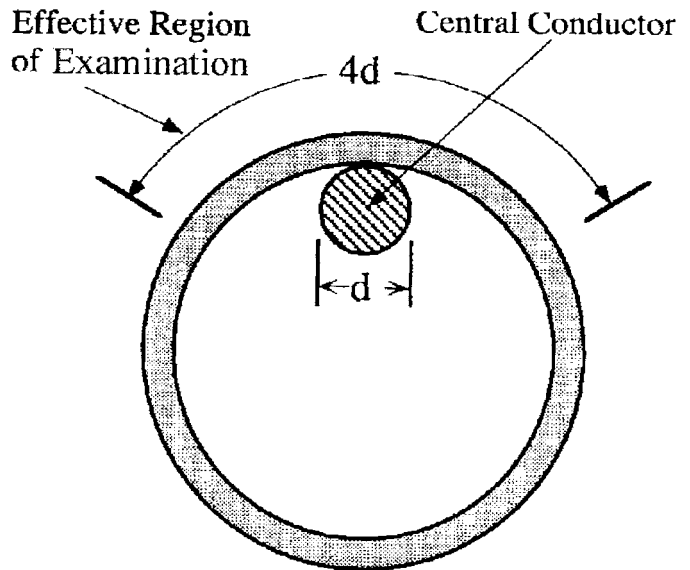

**FIG. 3 The Effective Region of Examination When Using an Offset Central Conductor is Equal to Four Times the Diameter of the Conductor as Indicated**

magnetic field overlap. See Appendix X5 for formulas that can be used in coil magnetization.

**6.4 Particle Application:**

**6.4.1 Dry Magnetic Particle Application, Continuous Method**—When using dry particles, the flow of magnetizing current shall be initiated prior to application of the magnetic particles to the surface under examination and terminated after powder application has been completed and any excess blown off. Precautions shall be taken to prevent any damage to the part due to overheating.

**6.4.1.1** Apply dry powder so that a light, uniform, dust-like coating settles on the surface of the part under examination while the part is being magnetized. Specially designed powder blowers or shakers using compressed air or hand power shall be used. The applicators shall introduce the particles into the air in a manner such that they reach the part surface in a uniform cloud with a minimum of force.

**6.4.1.2** After the powder is applied, and before the magnetizing force is removed, excess powder shall be removed, if it interferes with interpretation and evaluation, by means of a dry air current with sufficient force to remove the excess particles, but not strong enough to disturb particles held by a leakage field that is indicative of discontinuities. In order to recognize the broad, fuzzy, lightly held powder patterns formed by near-surface discontinuities, the formation of indications must be observed carefully during both powder application and removal of the excess powder. The dry particle method shall not be used to examine aerospace components (flight hardware).

**6.4.2 Wet Magnetic Particle Application, Continuous Method**—Fluorescent or nonfluorescent particles suspended in a liquid vehicle at the required concentration shall be applied by gently spraying or flowing the suspension over the area to be examined or by immersion of the part in the suspension.

**6.4.2.1** Proper sequencing and timing of part magnetization and application of particle suspension are required to obtain the

proper formation and retention of indications. This requires that the stream of suspension be diverted from the part simultaneously with, or slightly before, energizing the magnetic circuit.

6.4.2.2 The magnetizing current shall be applied for a duration of at least  $\frac{1}{2}$  s for each application, with a minimum of two shots being used. The second shot shall follow the first in rapid succession. It should come after the flow of suspension has been interrupted and before the part is examined for indications.

6.4.2.3 Under special circumstances, such as the use of automated equipment or for critical parts, the  $\frac{1}{2}$  s duration and the two-shot requirement may be waived provided it is demonstrated that the procedure can detect known discontinuities in reference parts.

6.4.2.4 Care shall be exercised to prevent any damage to the part due to overheating or other causes. Weakly held indications on highly finished parts are readily washed away, and hence care must be exercised to prevent high-velocity flow over critical surfaces.

6.4.3 *Residual Magnetization Method*—In the residual magnetization method, the magnetic particles are applied to the part under examination immediately after the magnetizing force has been discontinued. The residual method is not as sensitive as the continuous method. It can be useful, for example, in detecting service induced fatigue cracks on the surface of materials with high retentivity. It is also useful for the examination of parts or areas of parts, which because of geometric constraints, cannot be examined with the continuous method. The residual method shall be used only when specifically approved by the Cognizant Engineering Organization or when it has been documented that it can detect discontinuities or artificial discontinuities in parts under examination. The test parts shall have the same material and processing steps, and similar geometry, to the actual parts being examined.

6.4.4 *Magnetic Slurry/Paint Application*—Magnetic paints or slurries are applied to the part with a brush, squeeze bottle, or aerosol can before or during the magnetization operation. This method is for special applications, such as overhead or underwater examination. This method may be used only when specifically approved by the Cognizant Engineering Organization.

6.4.5 *Magnetic Polymer Application*—Polymerizable material containing magnetic particles shall be held in contact with the part under examination during the period of its cure. Before curing takes place, and while the magnetic particles are still mobile, the part shall be magnetized to the specified level. This requires prolonged or repeated periods of magnetization. This method is for special applications, such as bolt holes which cannot be examined readily by the wet or dry method, and shall be used only when specifically approved by the Cognizant Engineering Organization. AMS-I-83387 establishes the examination process for magnetic rubber.

6.4.6 *Particle Selection for Aerospace Lifting Hardware*—The use of dry powder or non-fluorescent wet particles on aerospace lifting hardware must be approved by the Cognizant Engineering Organization.

6.5 *Evaluation*—Following magnetization and particle application, the parts shall be examined for indications. All indications will be identified as relevant or nonrelevant. Relevant indications will be compared to accept/reject criteria and the parts accepted or rejected accordingly.

6.6 *Recording of Indications*—When required by the written procedure, the location of all rejectable indications shall be marked on the part, and permanent records of the location, direction, and frequency of indications may be made by one or more of the following methods:

6.6.1 *Written Description*—By recording the location, length, direction, and number of indications in sketch or tabular form.

6.6.2 *Transparent Tape*—For dry particle indications, by applying transparent adhesive-backed tape to which the indications will adhere and placing it on an approved form along with information giving its location on the part.

6.6.3 *Strippable Film*—By covering the indication with a spray-on strippable film that fixes the indications in place and placing the resultant reproduction on an approved form along with information giving its location on the part.

6.6.4 *Photography*—By photographing or video recording the indications themselves, the tape, or the strippable film reproduction and placing the photograph in a tabular form along with information giving its location on the part.

6.7 *Post Examination Demagnetization and Cleaning*—All parts shall be demagnetized and cleaned after final examination. Apply corrosion protection as required.

6.7.1 *Demagnetization:*

6.7.1.1 When using AC demagnetization, the part shall be subjected to a field with a peak value greater than, and in nearly the same direction as, the field used during examination. This AC field is then decreased gradually to zero. When using an AC demagnetizing coil, hold the part approximately 1 ft [30 cm] in front of the coil and then move it slowly and steadily through the coil and at least 3 ft [100 cm] beyond the end of the coil while the current is flowing. Repeat this process as necessary. Rotate and tumble parts of complex configuration while passing through the field of the coil.

6.7.1.2 When using DC demagnetization, the initial field shall be higher than, and in nearly the same direction as, the field reached during examination. The field shall then be reversed, decreased in magnitude, and the process repeated (cycled) until an acceptably low value of residual field is reached.

6.7.1.3 Whenever possible, parts that have been magnetized circularly shall be magnetized in the longitudinal direction before being demagnetized. After demagnetization, a magnetic field probe or strength meter shall not detect fields with an absolute value above 3 G ( $3 \times 10^{-4}$  T) anywhere on the part.

6.7.2 *Postinspection Cleaning*—Cleaning shall be done with a suitable solvent, air blower, or by other means.

6.7.2.1 Parts shall be examined to ensure that the cleaning procedure has removed magnetic particle residues from holes, crevices, passage ways, etc. Such residue could have an adverse effect on the intended use of the part.

6.7.2.2 Care shall be taken to remove all plugs, masking, or other processing aids that may affect the intended use of the part.

6.7.2.3 Parts shall be protected from corrosion or damage as required.

## 7. Quality Control

7.1 *System Performance Verification*—The overall performance of the magnetic particle examination system, including the equipment, materials, and the lighting environment being used, shall be verified initially and at regular intervals thereafter. The required verification intervals are stated in **Table 1**. Records of the verification results shall be maintained and retained for the time period specified in the contract. Establish a system in accordance with ANSI Z540-1 or **ISO 10012-1** for calibration and certification of all current and voltage measuring devices, ammeter shunts, timers, and gaussmeters used in verification.

7.1.1 *Use of Test Parts with Discontinuities*—A reliable method for system performance verification is the use of representative reference parts containing discontinuities of the type, location, and size specified in the acceptance requirements and examined (or inspected) in accordance with a written procedure. If correct magnetic particle indications can be produced and identified in these representative parts, the overall system performance is verified. Parts used for verification will be demagnetized, cleaned thoroughly following the examination, and checked under black or visible light, as appropriate to the examination process, to ensure that residual indications do not remain.

7.1.2 *Fabricated Test Parts with Artificial Discontinuities*—When actual production parts with known discontinuities of the type, location, and size needed for verification are not available or are impractical, fabricated test or production parts with artificial discontinuities or a ring specimen similar to the ring in **Appendix X1** may be used. Artificial discontinuities may be fabricated to meet a particular need or may be commercially available magnetic field indicators or shims as shown in **Appendix X2**. All applicable conditions for the use of such reference parts, as described in 7.1.1, shall apply.

7.2 *Suspension Vehicle Tests* (Not required for aerosol can solutions):

7.2.1 *Concentration/Contamination Tests*—Particle concentration and contamination shall be determined upon start up, at regular intervals thereafter, and whenever the bath is changed or adjusted. The required testing intervals are stated in **Table 1**.

7.2.1.1 *Determination of Wet Particle Concentration*—Agitate the particle suspension a minimum of 30 min to ensure uniform distribution of particles throughout the bath. Place a 100-mL sample of the agitated suspension in a pear-shaped centrifuge tube (of the size and shape specified in Test Method **D1966**, except the stem shall be graduated to 1 mL in 0.05-mL increments for fluorescent particles and graduated to 1.5 mL in 0.1 mL increments for visible particles). Demagnetize the sample and allow the tube to stand undisturbed for a settling time of at least 60 min if using petroleum distillate or 30 min for conditioned water suspension. Read the volume of settled particles. If the concentration is out of the tolerance stated in

the written procedure add particles or suspension vehicle, as required, and re-determine the particle concentration. If the settled particles appear to be loose agglomerates rather than a solid layer, take a second sample. If the second sample also appears agglomerated, replace the entire suspension. Thirty-minute settling times (for oil suspensions), or other accelerated tests, may be used if they have been verified to give results equivalent to the procedure described in this paragraph.

7.2.1.2 *Determination of Wet Particle Contamination*—Perform the tests specified in 7.2.1.1. Examine the graduated portion of the tube, under both black light (for fluorescent baths only) and visible light (for both fluorescent and nonfluorescent baths), for striations or bands, different in color or appearance. Bands or striations may indicate contamination. If the total volume of the contaminants, including bands or striations, exceeds 30 % of the volume of magnetic particles the bath must be adjusted or replaced.

7.2.2 *Water Break Test*—In this test of water-based vehicles, a clean part with a surface finish the same as the parts to be examined or an actual production part is flooded with the conditioned water, and the appearance of the surface is noted after flooding is stopped. If a continuous even film forms over the entire part, sufficient wetting agent is present. If the film of suspension breaks, exposing bare surface, insufficient wetting agent is present or the part has not been cleaned adequately.

7.2.3 *Determination of Particle Sensitivity*—**Appendix X7** describes several devices that can demonstrate the sensitivity of either wet-method or dry-method particles. These devices contain permanent magnetization in some form and are independent of the magnetizing system. They should not be magnetized or demagnetized before or after use. Such devices can be useful whenever performance of the particles are subject to question or need to be verified.

7.3 *Equipment Calibration*—Magnetic particle examination equipment shall be checked for performance and accuracy at the time of purchase and at intervals thereafter as indicated in **Table 1**; whenever malfunction is suspected, when specified by the Cognizant Engineering Organization, or whenever electrical maintenance that might affect equipment accuracy is performed.

7.3.1 *Ammeter Accuracy*—To check the equipment ammeter, a calibrated ammeter shall be connected in series with the output circuit. Comparative readings shall be taken at three output levels encompassing the usable range of the equipment. The equipment meter reading shall not deviate by more than  $\pm 10\%$  or 50 amperes, whichever is greater, from the current value shown by the calibrated ammeter. (When measuring half-wave rectified current, the current values shown by the calibrated DC ammeter readings shall be doubled.) The frequency of the ammeter check is specified in **Table 1**.

7.3.2 *Timer Control Check*—On equipment using a timer to control the current duration, the timer should be calibrated to within  $\pm 0.1$  s using a suitable electronic timer.

7.3.3 *Magnetic Field Quick Break Check*—On equipment that uses a quick break feature, proper functioning of this circuit shall be verified. The test may be performed using a suitable oscilloscope or other applicable method as specified by the equipment manufacturer.



7.3.4 *Dead Weight Check*—Yokes and permanent magnets (when allowed) shall be dead weight tested at intervals as stated in **Table 1**. Alternating current and permanent magnet yokes shall have a lifting force of at least 10 lb [4.5 kg], with a 2- to 6-in. [50- to 150-mm] spacing between legs. Direct current yokes shall have a lifting force of at least 30 lb [13.5 kg], with a 2- to 4-in. [50- to 100-mm] spacing between legs, or 50 lb [22.5 kg], with a 4- to 6-in. [100- to 150-mm] spacing.

7.3.5 *Black Lights*—Black lights, portable, hand-held, permanently mounted or fixed, which are used to inspect parts, shall be checked for output at the frequency specified in **Table 1** and after bulb replacement. A longer period may be used if a plan justifying this extension is prepared by the NDT facility or its delegate. Minimum acceptable intensity is 1000  $\mu\text{W}/\text{cm}^2$  at 15 in. [38.1 cm] from the front of the filter to the face of the sensor. All black light filters shall be replaced or otherwise corrected as appropriate.

7.4 *Marking of Accepted Parts*—Unless otherwise specified by the Cognizant Engineering Organization, parts that have been accepted using magnetic particle examination shall be marked in accordance with the applicable drawing, purchase order, contract, or as specified herein prior to leaving the examination facility.

7.4.1 Marking shall be applied in such a manner and location as to be harmless to the part. The identification shall not be obliterated or smeared by subsequent handling and, when practicable, placed in a location that will be visible after assembly.

7.4.1.1 When subsequent processing would remove the identification, the applicable marking shall be affixed to the record accompanying the finished parts or assembly.

7.4.1.2 Bolts and nuts and other fastener products may be identified as having met the requirements of magnetic particle examination by marking each package conspicuously.

7.4.2 *Impression Stamping, Ink Stamping, Laser Marking, Dyeing, Vibro Engraving or Etching*—Impression stamping, ink stamping, laser marking, dyeing, vibro engraving or etching may be used when permitted or required by the applicable written procedure, detail specification or drawing, or when the nature of the part is such as to provide for impression stamping of part numbers or other examination personnel markings. Impression stamping shall be located only in the area provided adjacent to the part number or examination personnel's stamp.

7.4.3 *Other Identification*—Other means of identification, such as tagging, may be used for parts that have a configuration or function precluding the use of stamping, vibro engraving, or etching, as in the case of completely ground or polished balls, rollers, pins, or bushings.

7.5 *Identifying Symbols and Color Markings:*

7.5.1 *One-Hundred Percent Examination*—When items are examined and accepted by 100 % examination, each item shall be marked as follows:

7.5.1.1 *Dyeing*—When dyeing is applicable, a dye of acceptable adherence which is predominantly blue (in accordance

with **FED-STD-595**) shall be employed. However, if a color conflict is incurred with any other method, magnetic particle examination may be indicated by two adjacent blue dots or other suitable means.

7.5.1.2 *Stamping, Laser Marking, Vibro Engraving, or Etching*—When impression stamping or ink stamping, laser marking, vibro engraving, or etching is used to mark 100 % examined parts, the letter “M” with a circle around it shall be employed.

7.5.2 *Marking Accepted Lots*—When items are accepted by means of a sampling procedure, each item of an accepted lot shall be marked as follows:

7.5.2.1 *Dyeing*—When dyeing is applicable, a dye of acceptable adherence that is predominantly orange (in accordance with **FED-STD-595**) shall be employed.

7.5.2.2 *Stamping, Laser Marking Vibro Engraving, or Etching*—When impression stamping, vibro engraving or etching is used to mark lot examined parts, the letter “M”, without a circle around it shall be employed.

7.6 *Eye Glasses*—When using fluorescent materials, examination personnel shall not wear eye glasses that are photochromic or that have permanently darkened lenses. This is not intended to prohibit the use of eyeglasses with lenses treated to absorb ultraviolet light.

7.7 *Safety*—The safe handling of magnetic particles (wet or dry), oil vehicles, water baths, and water conditioner concentrates are governed by the suppliers' Material Safety Data Sheets (MSDS). Material Safety Data Sheets, conforming to **29 CFR 1910.1200**, or equivalent, must be provided by the supplier to any user and shall be prepared in accordance with **FED-STD-313**.

7.7.1 *Flammability*—Flash point of oil vehicles shall be in accordance with **AMS 2641**. The suppliers' MSDS shall certify the flash point.

7.7.2 *Personnel Hazards*—Precautions against inhalation, skin contact, and eye exposure are detailed in the suppliers' MSDS. These precautions shall be observed.

7.7.3 *Electrical Hazards*—Magnetizing equipment shall be maintained properly to prevent personnel hazards from electrical short circuits. Care must be taken to reduce arcing and the possible ignition of oil baths.

7.7.4 *Black Light*—Replace cracked or broken ultraviolet filters immediately. Broken filters can continue to radiate ultraviolet energy and must be replaced immediately. Spectacles designed to absorb ultraviolet wavelength radiation are suggested for close, high black light intensity, examination.

7.8 *Dark Adaptation*—Personnel must wait at least 1 min after entering a darkened area for their eyes to adjust to the low-level lighting before performing fluorescent magnetic particle examination.

## 8. Keywords

8.1 dye; fluorescent; magnetic particle; nondestructive evaluation; nondestructive examination; nondestructive testing

## ANNEXES

### (Mandatory Information)

#### A1. INSTRUCTIONS FOR THE USE OF AS 5371 STANDARD NOTCHED SHIMS

A1.1 *Application of Shims*—The Reference Standard Notched Shims of AS 5371, as shown in Appendix X2, require specific handling, attachment, and care for accurate indication of magnetic field strength and direction. To select amperage settings for multi-directional magnetization, the use of AS 5371 shims or parts described in 6.3.1.1 is mandatory.

A1.2 Shims 0.002 in. [0.05 mm] thick shall be used on curved or complex surfaces.

A1.3 Shims are manufactured of low carbon steel and must be protected from corrosion when not in use. They may be submerged in a solvent such as MEK or naphtha for storage. Before attaching the shim to the part, both the shim and part shall be clean and dry.

A1.4 The shim shall be placed in intimate contact with the part with the flaw side next to the material to be tested.

A1.5 The shim shall be securely fastened to the part by using an adhesive or tape (such as Scotch Brand 191, 471, or 600 series) that prevents the magnetic particle suspension from entering between the shim and part. Whatever means is used to secure the shim to the part shall not interfere with the visibility of the indications.

A1.6 Tape may be used to secure the shim and shall have the following properties: (1) Good adhesion to steel, (2) Impervious to the suspension used, and (3) the tape shall be non-fluorescent (for fluorescent suspensions).

A1.7 If the tape becomes loose, allowing the suspension to seep under the shim, the tape and shim shall be carefully removed, the shim and the part shall be cleaned and the shim shall be reattached.

A1.8 Re-use of the shims is acceptable, provided they are not distorted when removed and intimate contact is achieved when replaced.

A1.9 *Determining Field Strength and Direction*—Use of the circle or cross configuration shims will indicate fields in any direction.

A1.9.1 In developing a magnetic particle procedure, first determine the locations the shims should be placed to ensure adequate coverage to monitor the field strength and direction, and then attach the shims.

A1.9.2 Using the continuous method, begin by starting the amperage selection at a minimum level and increasing the amperage slowly until the shim indication(s) is readily observed. When magnetized, one leg of the X will be indicated perpendicular to the field direction and the circle shim will show in the areas that are approximately perpendicular to the direction of the applied field.

A1.9.3 In multi-directional magnetization, longitudinal and circular fields shall be determined separately as follows:

A1.9.3.1 Field strength for the first direction shall be determined by slowly increasing the amperage until a satisfactory indication on each shim is observed.

A1.9.3.2 Record the setting.

A1.9.3.3 Carefully clean the shims prior to determining the amperage in the next direction.

A1.9.3.4 Field strength for the second direction shall be determined by incrementally increasing the amperage until a satisfactory indication on each shim is observed.

A1.9.3.5 Record the setting.

A1.9.4 Place the selector switch in the multi-directional mode and magnetize the part at the recorded settings. If the entire circle on the shims is observed, the fields are in balance. If any portion of the circle has a weak indication, adjust the amperage accordingly and repeat field verification process until the magnetic fields are balanced.

A1.9.5 Use care when applying the suspension to the shims. Proper shim indications may not form unless the suspension is applied in a gentle manner.

A1.10 The shims are made of a low retentivity and high permeability material that cannot be used for indicating residual fields when developing magnetic particle inspection procedures.

A1.11 Actual field strength measurements can be obtained by placing a Hall Effect probe adjacent to the shim or at a nearby location where probe placement can easily be repeated.

#### A2. INSTRUCTIONS FOR THE USE OF FLEXIBLE LAMINATED STRIPS

A2.1 *Application of Strips*—Flexible laminated strips, as shown in Appendix X3, require specific handling, attachment, and care for accurate indication of magnetic field direction.

A2.2 Strips are manufactured of high permeability carbon steel and must be protected from corrosion when not in use.

They should be stored in a dry location. Before placing the strip onto the part, both the strip and part shall be clean and dry.

A2.3 The strip shall be placed in intimate contact with material to be tested. The strip may be held in place manually or with the use of an adhesive or tape.