



Designation: C 1072 – 05a

Standard Test Method for Measurement of Masonry Flexural Bond Strength¹

This standard is issued under the fixed designation C 1072; the number immediately following the designation indicates the year of original adoption or, in the case of revision, the year of last revision. A number in parentheses indicates the year of last approval. A superscript epsilon (ϵ) indicates an editorial change since the last revision or reapproval.

This standard has been approved for use by agencies of the Department of Defense.

1. Scope*

1.1 This test method covers the determination of flexural bond strength of nonreinforced masonry by physical testing of each joint of masonry prisms.

1.2 *This standard does not purport to address all of the safety concerns, if any, associated with its use. It is the responsibility of the user of this standard to establish appropriate safety and health practices and determine the applicability of regulatory limitations prior to use.*

2. Referenced Documents

2.1 *ASTM Standards:*²

C 67 Test Methods of Sampling and Testing Brick and Structural Clay Tile

C 140 Test Methods of Sampling and Testing Concrete Masonry Units

C 270 Specification for Mortar for Unit Masonry

C 780 Test Method for Preconstruction and Construction Evaluation of Mortars for Plain and Reinforced Unit Masonry

C 1357 Test Methods for Evaluating Masonry Bond Strength

C 1532 Practice for Selection, Removal, and Shipment of Masonry Assemblage Specimens from Existing Construction

3. Significance and Use

3.1 This test method is intended to provide a simple and economical means for the determination of comparative values of flexural bond strength. It may be used either on specimens especially fabricated for bond strength evaluation or on specimens cut from existing masonry.

3.2 The bond strengths determined from this test method can be used as a means of evaluating the compatibility of mortars and masonry units. It may also be used to determine the effect on flexural bond strength of such factors as masonry unit and mortar properties, workmanship, curing conditions, coatings on masonry units, or any other factors that may be of concern.

3.3 Flexural bond strength determined by this test method should not be interpreted as the flexural bond strength of a wall constructed of the same material. However, results may be used to predict the flexural strength of a wall. Nor should it be interpreted as an indication of extent of bond for purposes of water permeance evaluation.

4. Apparatus

4.1 The test apparatus is shown in **Figs. 1-4**. The upper and lower clamping mechanisms shall be constructed as shown, except that the hex head bolts are permitted to be replaced by other tightening devices of equal, or greater, strength and stiffness. The support frame shall be constructed as shown or shall be constructed using configurations and materials of equal, or greater, strength and stiffness. The testing apparatus shall be constructed to apply the load vertically downward on the upper clamping system in such a manner that the upper and lower clamp do not come in contact during the tests. The prism support system shall be able to accommodate the size of the prism to be tested.

5. Sampling and Testing

5.1 *Brick Masonry Units*—Representative brick masonry units shall be sampled and tested in accordance with Test Methods **C 67**.

NOTE 1—Brick properties for which there are methods of test in Test Methods **C 67** that may be of interest are cold-water absorption, boiling-water absorption, initial rate of absorption, and compressive strength.

5.2 *Concrete Masonry Units*—Representative concrete masonry units shall be sampled and tested in accordance with Test Methods **C 140**.

¹ This test method is under the jurisdiction of ASTM Committee C15 on Manufactured Masonry Units and is the direct responsibility of Subcommittee C15.04 on Research.

Current edition approved May 15, 2005. Published July 2005. Originally approved in 1993. Last previous edition approved in 2005 as C 1072-05.

² For referenced ASTM standards, visit the ASTM website, www.astm.org, or contact ASTM Customer Service at service@astm.org. For *Annual Book of ASTM Standards* volume information, refer to the standard's Document Summary page on the ASTM website.

*A Summary of Changes section appears at the end of this standard.

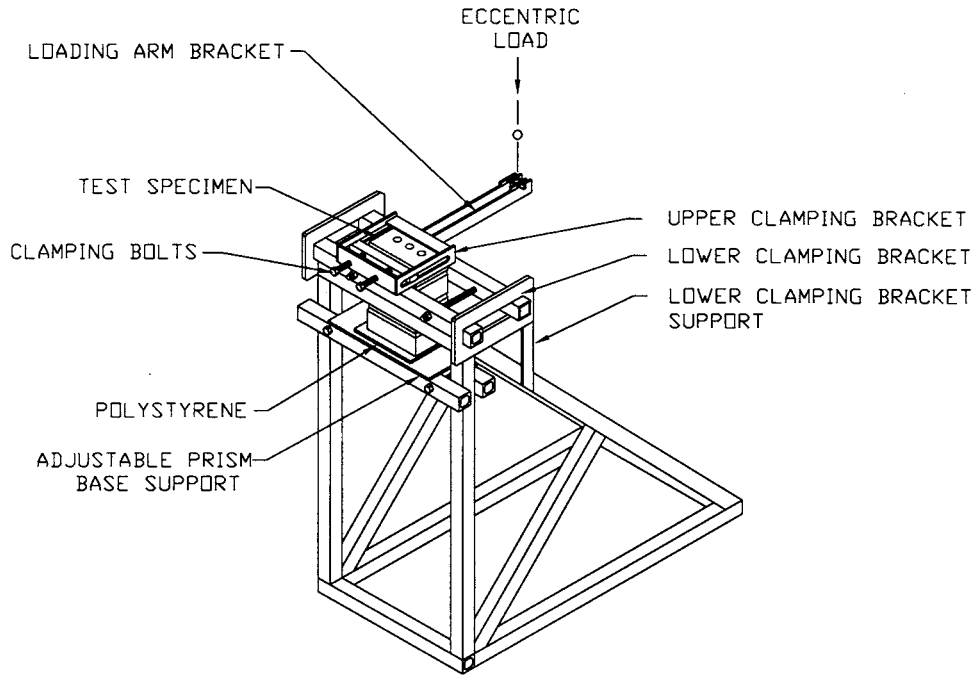

FIG. 1 Bond Wrench Testing Apparatus

5.3 *Mortar*—When mortar property testing is specified, the compressive strength, air content, initial flow, cone penetration, and water retention shall be determined in accordance with the requirements of Specification C 270 or Test Method C 780.

6. Test Specimen

6.1 The test specimen shall consist of one or more prism(s). Each prism shall have not more than five joints and a minimum width (*b*) of 4 in. (see Note 2) as shown in Fig. X1.1.

NOTE 2—It is recommended that a width (*b*) of 1 full masonry unit be used. However, full widths may not be possible for samples obtained in accordance with 6.3.2.

6.2 Test a minimum of fifteen joints for prisms fabricated in the laboratory or field, and five joints for prisms removed from existing masonry.

6.3 Construct prisms in a laboratory or in the field or remove from existing masonry. Keep handling of the prisms to a minimum and handle in such a way that the joints will not be subjected to detrimental tensile stresses.

6.3.1 Prisms Fabricated in Laboratory or Field:

6.3.1.1 Set the first unit of each prism on a firm, horizontal surface without the use of mortar.

NOTE 3—An alignment device may be used to ensure plumbness and joint thickness uniformity.

6.3.1.2 Place a full or face shell mortar bed on all units without furrowing unless the effect of furrowing is being studied.

6.3.1.3 Immediately place the next course on the mortar bed and tap it to proper level and joint thickness. One face of each prism shall be in a nearly true plane.

6.3.1.4 Repeat 6.3.1.2 and 6.3.1.3 until the prisms are the desired height. Identify all specimens using a water-resistant marker.

6.3.1.5 Depending upon the desired test conditions, strike flush or tool the mortar joints. If tooling is required, tool only the joints on one face of each prism.

6.3.1.6 Unless specified otherwise, enclose all prisms in a moisture-tight bag and cure for 28 days. Record and report the daily high and low temperatures in the area where specimens are stored for curing. For prisms cured in laboratory air, maintain the laboratory air at 75 ± 15 °F (24 ± 8 °C). If other curing conditions (e.g. no moisture-tight bag) are specified, record and report all details of the curing.

NOTE 4—Workmanship during fabrication, temperature of the materials during fabrication, curing conditions, time between removal from moist curing to test, and other factors may affect the bond strengths measured by this test. Standardized specimen fabrication and curing procedures that attempt to control these variables are prescribed in Test Methods C 1357.

6.3.1.7 When prisms are made during construction at the job site, they shall be constructed in a location where they will not be disturbed, but will be subjected to atmospheric conditions similar to those in the masonry structure whose properties they are intended to represent.

6.3.2 Prisms Obtained from Existing Masonry:

6.3.2.1 Remove, document and transport prisms from existing masonry in accordance with Practice C 1532.

6.3.2.2 Where mortar fins and extrusions project from the specimen to the extent that they may interfere with the attachment of the bond wrench, they shall be removed without causing damage to the specimen. Remove only enough material to enable proper attachment of the bond wrench.