



Designation: D 2700 – 01a

An American National Standard



Designation: 236/87

Standard Test Method for Motor Octane Number of Spark-Ignition Engine Fuel¹

This standard is issued under the fixed designation D 2700; the number immediately following the designation indicates the year of original adoption or, in the case of revision, the year of last revision. A number in parentheses indicates the year of last reapproval. A superscript epsilon (ϵ) indicates an editorial change since the last revision or reapproval.

1. Scope

1.1 This laboratory test method covers the quantitative determination of the knock rating of liquid spark-ignition engine fuel in terms of Motor octane number except that this test method may not be applicable to fuel and fuel components that are primarily oxygenates.² The sample fuel is tested in a standardized single cylinder, four-stroke cycle, variable compression ratio, carbureted, CFR engine run in accordance with a defined set of operating conditions. The octane number scale is defined by the volumetric composition of primary reference fuel blends. The sample fuel knock intensity is compared to that of one or more primary reference fuel blends. The octane number of the primary reference fuel blend that matches the knock intensity of the sample fuel establishes the Motor octane number.

1.2 The octane number scale covers the range from 0 to 120 octane number, but this test method has a working range from 40 to 120 octane number. Typical commercial fuels produced for automotive spark-ignition engines rate in the 80 to 90 Motor octane number range. Typical commercial fuels produced for aviation spark-ignition engines rate in the 98 to 102 Motor octane number range. Testing of gasoline blend stocks or other process stream materials can produce ratings at various levels throughout the Motor octane number range.

1.3 The values of operating conditions are stated in SI units and are considered standard. The values in parentheses are the historical inch-pounds units. The standardized CFR engine measurements continue to be in inch-pound units only because of the extensive and expensive tooling that has been created for this equipment.

1.4 *This standard does not purport to address all of the safety concerns, if any, associated with its use. It is the responsibility of the user of this standard to establish appro-*

priate safety and health practices and determine the applicability of regulatory limitations prior to use. For more specific hazard statements, see Section 8, 13.4.1, 14.5.1, 15.6.1, Annex A1, A2.3.9, A2.4.8, A3.2.7.2(7), A4.2.3.1, A4.2.3.3(6) and (9), A4.3.5, X2.3.7, X3.2.3.1, X3.3.4.1, X3.3.9.3, X3.3.12.4, and X3.5.1.8.

2. Referenced Documents

2.1 ASTM Standards:

- D 1193 Specification for Reagent Water³
- D 1744 Test Method for Water in Liquid Petroleum Products by Karl Fischer Reagent⁴
- D 2268 Test Method for Analysis of High-Purity *n*-Heptane and Isooctane by Capillary Gas Chromatography⁴
- D 2360 Test Method for Trace Impurities in Monocyclic Aromatic Hydrocarbons by Gas Chromatography⁵
- D 2699 Test Method for Research Octane Number of Spark Ignition Engine Fuel⁶
- D 2885 Test Method for Research and Motor Method Octane Ratings Using On-Line Analyzers⁶
- D 3116 Test Method for Trace Amounts of Lead in Gasoline⁷
- D 3237 Test Method for Lead in Gasoline by Atomic Absorption Spectrometry⁸
- D 3703 Test Method for Peroxide Number of Aviation Turbine Fuels⁸
- D 4057 Practice for Manual Sampling of Petroleum and Petroleum Products⁸
- D 4175 Terminology Relating to Petroleum, Petroleum Products, and Lubricants⁸
- D 4177 Practice for Automatic Sampling of Petroleum and Petroleum Products⁸
- D 4814 Specification for Automotive Spark-Ignition Engine Fuel⁸

¹ This test method is under the jurisdiction of ASTM Committee D02 on Petroleum Products and Lubricants and is the direct responsibility of Subcommittee D02.01 on Combustion Characteristics.

Current edition approved Sept. 10, 2001. Published October 2001. Originally published as D 2700 – 68. Last previous edition D 2700 – 01.

² Research octane number, determined using Test Method D 2699, is a companion method to provide a similar but typically higher octane rating under milder operating conditions.

³ *Annual Book of ASTM Standards*, Vol 11.01.

⁴ *Annual Book of ASTM Standards*, Vol 05.01.

⁵ *Annual Book of ASTM Standards*, Vol 06.04.

⁶ *Annual Book of ASTM Standards*, Vol 05.05.

⁷ Discontinued; see 1994 *Annual Book of ASTM Standards*, Vol 05.02.

⁸ *Annual Book of ASTM Standards*, Vol 05.02.

E 1 Specification for ASTM Thermometers⁹
E 456 Terminology Relating to Quality and Statistics¹⁰
E 542 Practice for Calibration of Laboratory Volumetric Apparatus¹¹

2.2 *ANSI Standard*:¹²

C-39.1 Requirements for Electrical Analog Indicating Instruments

3. Terminology

3.1 Definitions:

3.1.1 *accepted reference value, n*—a value that serves as an agreed-upon reference for comparison, and which is derived as: (1) a theoretical or established value, based on scientific principles, or (2) an assigned or certified value, based on experimental work of some national or international organization, or (3) a consensus or certified value, based on collaborative experimental work under the auspices of a scientific or engineering group. **(E 456)**

3.1.1.1 *Discussion*—In the context of this test method, accepted reference value is understood to apply to the Motor octane number of specific reference materials determined empirically under reproducibility conditions by the National Exchange Group or another recognized exchange testing organization.

3.1.2 *Check Fuel, n*—for quality control testing, a spark-ignition engine fuel of selected characteristics having an octane number accepted reference value (O.N._{ARV}) determined by round-robin testing under reproducibility conditions.

3.1.3 *cylinder height, n*—for the CFR engine, the relative vertical position of the engine cylinder with respect to the piston at top dead center (tdc) or the top machined surface of the crankcase.

3.1.4 *dial indicator reading, n*—for the CFR engine, a numerical indication of cylinder height, in thousandths of an inch, indexed to a basic setting at a prescribed compression pressure when the engine is motored.

3.1.5 *digital counter reading, n*—for the CFR engine, a numerical indication of cylinder height, indexed to a basic setting at a prescribed compression pressure when the engine is motored.

3.1.6 *detonation meter, n*—for knock testing, the signal conditioning instrumentation that accepts the electrical signal from the detonation pickup and provides an output signal for display.

3.1.7 *detonation pickup, n*—for knock testing, a magnetostrictive-type transducer that threads into the engine cylinder and is exposed to combustion chamber pressure to provide an electrical signal that is proportional to the rate-of-change of cylinder pressure.

3.1.8 *dynamic fuel level, n*—for knock testing, test procedure in which the fuel-air ratio for maximum knock intensity for sample and reference fuels is determined using the falling level technique that changes carburetor fuel level from a high

or rich mixture condition to a low or lean mixture condition, at a constant rate, causing knock intensity to rise to a maximum and then decrease, thus permitting observation of the maximum knockmeter reading.

3.1.9 *equilibrium fuel level, n*—for knock testing, test procedure in which the fuel-air ratio for maximum knock intensity for sample and reference fuels is determined by making incremental step changes in carburetor fuel level, observing the equilibrium knock intensity for each step and selecting the level which produces the highest knock intensity reading.

3.1.10 *firing, n*—for the CFR engine, operation of the CFR engine with fuel and ignition.

3.1.11 *fuel-air ratio for maximum knock intensity, n*—for knock testing, that proportion of fuel to air that produces the highest knock intensity for each fuel in the knock testing unit, provided this occurs within specified carburetor fuel level limits.

3.1.12 *guide tables, n*—for knock testing, the specific relationship between cylinder height (compression ratio) and octane number at standard knock intensity for specific primary reference fuel blends tested at standard or other specified barometric pressure.

3.1.13 *knock, n*—in a spark-ignition engine, abnormal combustion, often producing audible sound, caused by autoignition of the air/fuel mixture. **(D 4175)**

3.1.14 *knock intensity, n*—for knock testing, a measure of the level of knock.

3.1.15 *knockmeter, n*—for knock testing, the 0 to 100 division indicating meter that displays the knock intensity signal from the detonation meter.

3.1.16 *motoring, n*—for the CFR engine, operation of the CFR engine without fuel and with the ignition shut off.

3.1.17 *octane number, n*—for spark-ignition engine fuel, any one of several numerical indicators of resistance to knock obtained by comparison with reference fuels in standardized engine or vehicle tests. **(D 4175)**

3.1.18 *motor octane number, n*—for spark-ignition engine fuel, the numerical rating of knock resistance obtained by comparison of its knock intensity with that of primary reference fuels when both are tested in a standardized CFR engine operating under the conditions specified in this test method.

3.1.19 *oxygenate, n*—an oxygen-containing organic compound, which may be used as a fuel or fuel supplement, for example, various alcohols and ethers. **(D 4175)**

3.1.20 *primary reference fuels, n*—for knock testing, isooctane, *n*-heptane, volumetrically proportioned mixtures of isooctane with *n*-heptane, or blends of tetraethyllead in isooctane that define the octane number scale.

3.1.21 *primary reference fuel blends below 100 octane, n*—the volume percent of isooctane in a blend with *n*-heptane that defines the octane number of the blend, isooctane being assigned as 100 and *n*-heptane as zero octane number.

3.1.22 *primary reference fuel blends above 100 octane, n*—the millilitres per U.S. gallon of tetraethyllead in isooctane that define octane numbers above 100 in accordance with an empirically determined relationship.

3.1.23 *repeatability conditions, n*—conditions where independent test results are obtained with the same method on

⁹ Annual Book of ASTM Standards, Vol 14.03.

¹⁰ Annual Book of ASTM Standards, Vol 14.02.

¹¹ Annual Book of ASTM Standards, Vol 14.04.

¹² Available from American National Standards Institute, 11 W. 42nd St., 13th Floor, New York, NY 10036.

identical test items in the same laboratory by the same operator using the same equipment within short intervals of time.

(E 456)

3.1.23.1 *Discussion*—In the context of this test method, a short time interval between two ratings on a sample fuel is understood to be not less than the time to obtain at least one rating on another sample fuel between them but not so long as to permit any significant change in the sample fuel, test equipment, or environment.

3.1.24 *reproducibility conditions, n*—conditions where test results are obtained with the same method on identical test items in different laboratories with different operators using different equipment. **(E 456)**

3.1.25 *spread, n—in knock measurement*, the sensitivity of the detonation meter expressed in knockmeter divisions per octane number.

3.1.26 *standard knock intensity, n—for knock testing*, that level of knock established when a primary reference fuel blend of specific octane number is used in the knock testing unit at maximum knock intensity fuel-air ratio, with the cylinder height (dial indicator or digital counter reading) set to the prescribed guide table value. The detonation meter is adjusted to produce a knockmeter reading of 50 for these conditions.

3.1.27 *toluene standardization fuels, n—for knock testing*, those volumetrically proportioned blends of two or more of the following: reference fuel grade toluene, *n*-heptane, and isooctane that have prescribed rating tolerances for O.N._{ARV} determined by round-robin testing under reproducibility conditions.

3.2 Abbreviations:

3.2.1 *ARV*—accepted reference value

3.2.2 *C.R.*—compression ratio

3.2.3 *IAT*—intake air temperature

3.2.4 *K.I.*—knock intensity

3.2.5 *MIXT*—mixture temperature

3.2.6 *O.N.*—octane number

3.2.7 *PRF*—primary reference fuel

3.2.8 *TSF*—toluene standardization fuel

4. Summary of Test Method

4.1 The Motor O.N. of a spark-ignition engine fuel is determined using a standard test engine and operating conditions to compare its knock characteristic with those of PRF blends of known O.N. Compression ratio and fuel-air ratio are adjusted to produce standard K.I. for the sample fuel, as measured by a specific electronic detonation meter instrument system. A standard K.I. guide table relates engine C.R. to O.N. level for this specific method. The fuel-air ratio for the sample fuel and each of the PRF blends is adjusted to maximize K.I. for each fuel.

4.1.1 The fuel-air ratio for maximum K.I. may be obtained (1) by making incremental step changes in mixture strength, observing the equilibrium K.I. value for each step, and then selecting the condition which maximizes the reading or (2) by picking the maximum K.I. as the mixture strength is changed from either rich-to-lean or lean-to-rich at a constant rate.

4.2 *Bracketing Procedures*—The engine is calibrated to operate at standard K.I. in accordance with the guide table. The fuel-air ratio of the sample fuel is adjusted to maximize the K.I., and then the cylinder height is adjusted so that standard

K.I. is achieved. Without changing cylinder height, two PRFs are selected such that, at their fuel-air ratio for maximum K.I., one knocks harder (higher K.I.) and the other softer (lower K.I.) than the sample fuel. A second set of K.I. measurements for sample fuel and reference fuels is required, and the sample fuel O.N. is calculated by interpolation in proportion to the differences in average K.I. readings. A final condition requires that the cylinder height used shall be within prescribed limits around the guide table value for the calculated O.N. Bracketing procedure ratings may be determined using either the equilibrium fuel level or dynamic fuel level approach.

4.3 *C.R. Procedure*—A calibration is performed to establish standard K.I. using the cylinder height specified by the guide table for the O.N. of the selected PRF. The fuel-air ratio of the sample fuel is adjusted to maximize the K.I. under equilibrium conditions; the cylinder height is adjusted so that standard K.I. is achieved. The calibration is reconfirmed and the sample fuel rating is repeated to establish the proper conditions a second time. The average cylinder height reading for the sample fuel, compensated for barometric pressure, is converted directly to O.N. using the guide table. A final condition for the rating requires that the sample fuel O.N. be within prescribed limits around that of the O.N. of the single primary reference blend used to calibrate the engine to the guide table standard K.I. condition.

5. Significance and Use

5.1 Motor O.N. correlates with commercial automotive spark-ignition engine antiknock performance under severe conditions of operation.

5.2 Motor O.N. is used by engine manufacturers, petroleum refiners and marketers, and in commerce as a primary specification measurement related to the matching of fuels and engines.

5.2.1 Empirical correlations that permit calculation of automotive antiknock performance are based on the general equation:

$$\text{Road } O.N. = (k_1 \times \text{Research } O.N.) + (k_2 \times \text{Motor } O.N.) + k_3 \quad (1)$$

Values of k_1 , k_2 , and k_3 vary with vehicles and vehicle populations and are based on road-octane number determinations.

5.2.2 Motor O.N., in conjunction with Research O.N., defines the antiknock index of automotive spark-ignition engine fuels, in accordance with Specification D 4814. The antiknock index of a fuel approximates the road octane ratings for many vehicles, is posted on retail dispensing pumps in the United States, and is referred to in vehicle manuals.

$$\text{Antiknock Index} = 0.5 \text{ Research } O.N. + 0.5 \text{ Motor } O.N. + 0 \quad (2)$$

This is more commonly presented as:

$$\text{Antiknock Index} = \frac{(R + M)}{2} \quad (3)$$

5.3 Motor O.N. is used for measuring the antiknock performance of spark-ignition engine fuels that contain oxygenates.

5.4 Motor O.N. is important in relation to the specifications for spark-ignition engine fuels used in stationary and other nonautomotive engine applications.

5.5 Motor O.N. is utilized to determine, by correlation

equation, the Aviation method O.N. or performance number (lean-mixture aviation rating) of aviation spark-ignition engine fuel.¹³

6. Interferences

6.1 Certain gases and fumes, which can be present in the area where the knock testing unit is located, may have a measurable effect on the Motor O.N. test result.

6.1.1 Halogenated refrigerant used in air conditioning and refrigeration equipment can promote knock. Halogenated solvents can have the same effect. If vapors from these materials enter the combustion chamber of the CFR engine, the Motor O.N. obtained for sample fuels can be depreciated.

6.2 Electrical power subject to transient voltage or frequency surges or distortion can alter CFR engine operating conditions or knock measuring instrumentation performance and thus affect the Motor O.N. obtained for sample fuels.

7. Apparatus

7.1 *Engine Equipment*¹⁴—This test method uses a single cylinder, CFR engine that consists of standard components as follows: crankcase, a cylinder/clamping sleeve assembly to provide continuously variable C.R. adjustable with the engine operating, a thermal syphon recirculating jacket coolant system, a multiple fuel tank system with selector valving to deliver fuel through a single jet passage and carburetor venturi, an intake air system with controlled temperature and humidity equipment, electrical controls, and a suitable exhaust pipe. The engine flywheel is belt connected to a special electric power-absorption motor utilized to both start the engine and as a means to absorb power at constant speed when combustion is occurring (engine firing). See Fig. 1.

7.1.1 See Annex A2 for details and a description of all critical, non-critical, and equivalent engine equipment.

7.2 *Instrumentation*¹⁴—This test method uses electronic detonation metering instrumentation to measure the intensity of combustion knock as well as conventional thermometry, gages, and general purpose meters.

7.2.1 See Annex A3 for details and a description of all critical, non-critical, and equivalent instrumentation.

7.3 *Reference and Standardization Fuel Dispensing Equipment*—This test method requires repeated volumetric blending of reference fuels and TSF materials. In addition, volumetric blending of dilute tetraethyllead in *isooctane* may be performed on-site for making rating determinations above 100 O.N. Blending shall be performed accurately because rating error is proportional to blending error. A set of burets, or accurate volumetric apparatus, shall be used and the desired batch quantity shall be collected in a glass, metal, or selected plastic container and thoroughly mixed before being introduced to the engine fuel system.

7.3.1 Calibrated burets or volumetric apparatus having a capacity of 200 to 500 mL and a maximum volumetric tolerance of $\pm 0.2\%$ shall be used for preparation of reference and standardization fuel blends. Calibration shall be verified in accordance with Practice E 542.

7.3.1.1 Calibrated burets shall be outfitted with a dispensing valve and delivery tip to accurately control dispensed volume. The delivery tip shall be of such design that shut-off tip discharge does not exceed 0.5 mL.

7.3.1.2 The rate of delivery from the dispensing system shall not exceed 400 mL per min.

7.3.1.3 The set of burets for the reference and standardization fuels shall be installed in such a manner and be supplied with fluids such that all components of each batch or blend are dispensed at the same temperature.

7.3.2 A calibrated buret, pipette assembly, or other liquid dispensing apparatus having a capacity of not more than 4.0 mL and a critically controlled volumetric tolerance shall be used for dispensing dilute tetraethyllead into 400 mL batches of *isooctane*. Calibration of the dispensing apparatus shall be verified in accordance with Practice E 542.

7.3.3 See Appendix X1 for dispensing system information.

7.4 Auxiliary Apparatus:

7.4.1 *Special Maintenance Tools*—A number of specialty tools and measuring instruments should be utilized for easy, convenient, and effective maintenance of the engine and testing equipment. Lists and descriptions of these tools and instruments are available from the manufacturer of the engine equipment and those organizations offering engineering and service support for this test method.

7.4.2 *Ventilation Hoods*—Handling of reference and standardization fuels, dilute tetraethyllead, and sample fuels having various hydrocarbon compositions is best conducted in a well ventilated space or in a laboratory hood where air movement across the area is sufficient to prevent operator inhalation of vapors.

7.4.2.1 General purpose laboratory hoods are typically effective for handling hydrocarbon fuel blending.¹⁵

7.4.2.2 A blending hood meeting the requirements for dispensing toxic material shall be utilized in testing laboratories that choose to prepare leaded *isooctane* PRF blends on-site.

8. Reagents and Reference Materials

8.1 *Cylinder Jacket Coolant*—Water shall be used in the cylinder jacket for laboratory locations where the resultant boiling temperature shall be $100 \pm 1.5^\circ\text{C}$ ($212 \pm 3^\circ\text{F}$). Water with commercial glycol-based antifreeze added in sufficient quantity to meet the boiling temperature requirement shall be used when laboratory altitude dictates. A commercial multi-functional water treatment material should be used in the coolant to minimize corrosion and mineral scale that can alter heat transfer and rating results.

8.1.1 Water shall be understood to mean reagent water conforming to Type IV, Specification D 1193. (**Warning**—Ethylene glycol based antifreeze is poisonous and may be harmful or fatal if inhaled or swallowed. See Annex A1.)

¹³ Correlation information is given in ASTM research report RR:D02-69, Aviation Gasoline Antiknock Quality by ASTM Methods D 614 and D 357. (Replaced by Test Method D 2700.) Refer to the Report Section, in this test method, for application of the correlation relationship.

¹⁴ Engine equipment and instrumentation are available from the single source manufacturer, Waukesha Engine, Dresser, Inc., 1000 W. St. Paul Avenue, Waukesha, WI 53188. Waukesha Engine also has CFR engine authorized sales and service organizations in selected geographical areas.

¹⁵ Refer to *Industrial Ventilation Manual*, published by the American Conference of Governmental Industrial Hygienists, Cincinnati, OH.

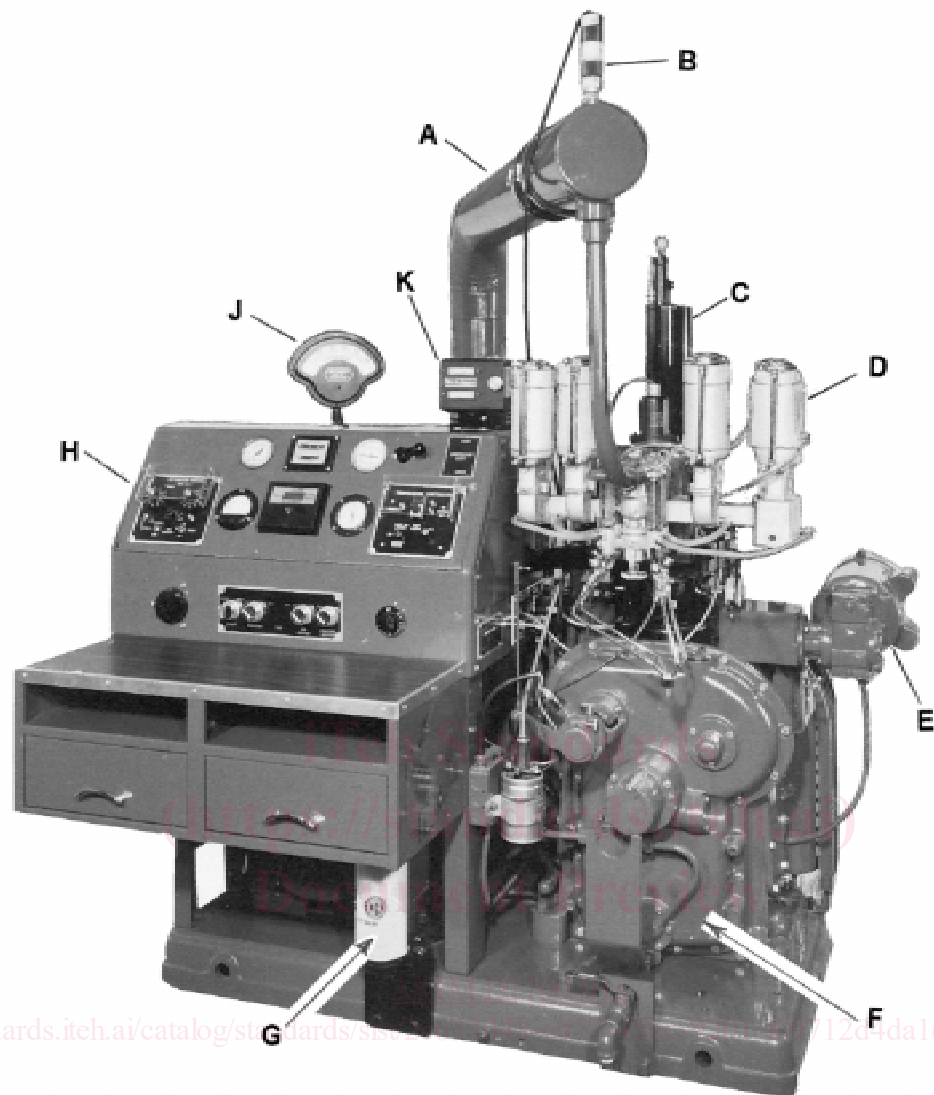

- A—Air humidifier tube
- B—Intake air heater
- C—Coolant condenser
- D—Four bowl carburetor
- E—C.R. change motor
- F—CFR-48 crankcase
- G—Oil filter
- H—Detonation meter
- J—Knockmeter
- K—C.R. digital counter

FIG. 1 Motor Method Test Engine Assembly

8.2 *Engine Crankcase Lubricating Oil*—An SAE 30 viscosity grade oil meeting the current API service classification for spark-ignition engines shall be used. It shall contain a detergent additive and have a kinematic viscosity from 9.3 to 12.5 mm² per s (cSt) at 100°C (212°F) and a viscosity index of not less than 85. Oils containing viscosity index improvers shall not be used. Multigraded oils shall not be used. (**Warning**—Lubricating oil is combustible and its vapor is harmful. See Annex A1.)

8.3 *Primary Reference Fuels*¹⁶, isooctane and normal heptane classified as reference fuel grade shall meet the specifications that follow: (**Warning**—PRF is flammable and its vapors are harmful. Vapors may cause flash fire. See Annex A1.)

¹⁶ Primary Reference Fuels are currently available from Chevron Phillips Chemical Company LP, 1301 McKinney, Suite 2130, Houston, TX 77010-3030 or Haltermann GmbH, Schopenstehl 15, 20095 Hamburg, Germany.

8.3.1 *Isooctane* (2,2,4-trimethylpentane) shall be no less than 99.75 % by volume pure, contain no more than 0.10 % by volume *n*-heptane, and contain no more than 0.5 mg/L (0.002 g/U.S. gal) of lead.¹⁷ (**Warning**—*Isooctane* is flammable and its vapors are harmful. Vapors may cause flash fire. See Annex A1.)

8.3.2 *n*-heptane shall be no less than 99.75 % by volume pure, contain no more than 0.10 % by volume *isooctane*, and contain no more than 0.5 mg/L (0.002 g/U.S. gal) of lead.¹⁷ (**Warning**—*n*-heptane is flammable and its vapors are harmful. Vapors may cause flash fire. See Annex A1.)

8.3.3 80 octane PRF blend¹⁸ prepared using reference fuel grade *isooctane* and *n*-heptane shall contain 80 ± 0.1 % by volume *isooctane*.¹⁹ (**Warning**—80 octane PRF is flammable and its vapors are harmful. Vapors may cause flash fire. See Annex A1.)

8.3.4 Refer to Annex A5 for octane numbers of various blends of 80 octane PRF and either *n*-heptane (see Table A5.1) or *isooctane* (see Table A5.2).

8.4 *Dilute Tetraethyllead*,²⁰ (commonly referred to as TEL Dilute Volume Basis) is a prepared solution of aviation mix tetraethyllead antiknock compound in a hydrocarbon diluent of 70 % (V/V) xylene, 30 % (V/V) *n*-heptane. (**Warning**—Dilute tetraethyllead is poisonous and flammable. It may be harmful or fatal if inhaled, swallowed, or absorbed through the skin. May cause flash fire. See Annex A1.)

8.4.1 The fluid shall contain 18.23 ± 0.05 % (m/m) tetraethyllead and have a relative density 15.6/15.6°C (60/60°F) of 0.957 to 0.967. The typical composition of the fluid, excluding the tetraethyllead is as follows:

Ingredient	Typical Concentration, % (m/m)
Ethylene dibromide (scavenger)	10.6
Diluent:	
xylene	52.5
<i>n</i> -heptane	17.8
Dye, antioxidant and inerts	0.87

8.4.2 Add dilute tetraethyllead, in mL quantities, to a 400-mL volume of *isooctane* to prepare PRF blends used for ratings over 100 O.N. The composition of the dilute fluid is such that when 2.0 mL are added to 400 mL of *isooctane*, the blend shall contain the equivalent of 2.0 mL of lead/U.S. gal (0.56 g of lead/L).²¹

8.4.3 Refer to Annex A5 for octane numbers of blends of tetraethyllead *isooctane* (see Table A5.3).

8.5 *Toluene, Reference Fuel Grade*²² shall be no less than 99.5 % by volume pure. Peroxide number shall not exceed 5 mg per kg (ppm). Water content shall not exceed 200 mg per kg.²³ (**Warning**—Toluene is flammable and its vapors are harmful. Vapors may cause flash fire. See Annex A1.)

8.5.1 Antioxidant shall be added by the supplier at a treat rate suitable for good long term stability as empirically determined with the assistance of the antioxidant supplier.

8.6 Check Fuels are in-house typical spark-ignition engine fuels having selected O.N. values, low volatility, and good long term stability. (**Warning**—Check Fuel is flammable and its vapors are harmful. Vapors may cause flash fire. See Annex A1.)

9. Sampling

9.1 Samples shall be collected in accordance with Practice D 4057 or D 4177.

9.2 *Sample Temperature*—Samples shall be cooled to a temperature of 2 to 10°C (35 to 50°F), in the container in which they are received, before the container is opened.

9.3 *Light Sensitive Samples*—Some materials present in spark-ignition engine fuels can be sensitive to light. Use of metallic or brown glass containers for samples is recommended. Introduction of sample fuel to the CFR engine carburetor shall be performed in a manner that minimizes exposure to bright light.

10. Basic Engine and Instrument Settings and Standard Operating Conditions

10.1 *Installation of Engine Equipment and Instrumentation*—Installation of the engine and instrumentation requires placement of the engine on a suitable foundation and hook-up of all utilities. Engineering and technical support for this function is required, and the user shall be responsible to comply with all local and national codes and installation requirements.

10.1.1 Proper operation of the CFR engine requires assembly of a number of engine components and adjustment of a series of engine variables to prescribed specifications. Some of these settings are established by component specifications, others are established at the time of engine assembly or after overhaul, and still others are engine running conditions that must be observed or determined by the operator during the testing process.

10.2 Conditions Based on Component Specifications:

10.2.1 *Engine Speed*—900 ± 9 rpm, when the engine is firing, with a maximum variation of 9 rpm occurring during a rating. Engine speed, while firing, shall not be more than 3 rpm greater than when it is motoring without combustion.

10.2.2 *Indexing Flywheel to Top-Dead-Center (tdc)*—With the piston at the highest point of travel in the cylinder, set the flywheel pointer mark in alignment with the 0° mark on the

¹⁷ Hydrocarbon composition shall be determined in accordance with Test Method D 2268. Lead contamination shall be determined in accordance with Test Method D 3116 or by careful application of Test Method D 3237.

¹⁸ 80 O.N. PRF are currently available from Chevron Phillips Chemical Company LP, 1301 McKinney, Suite 2130, Houston, TX 77010-3030 or Haltermann GmbH, Schopenstehl 15, 20095 Hamburg, Germany.

¹⁹ The supplier verifies that the blend contains by volume, 80 % *isooctane*, 20 % *n*-heptane using capillary gas chromatography and analytical calculations.

²⁰ Dilute tetraethyllead is available from Ethyl Corporation, 330 S. Fourth St., Richmond, VA 23219-4304; or from The Associated Ocel Company, Ltd., 23 Berkeley Square, London, England W1X 6DT.

²¹ Premixed PRF blends of *isooctane* containing specific amounts of tetraethyllead are currently available from Chevron Phillips Chemical Company LP, 1301 McKinney, Suite 2130, Houston, TX 77010-3030.

²² Toluene, reference fuel grade, is currently available from Chevron Phillips Chemical Company LP, 1301 McKinney, Suite 2130, Houston, TX 77010-3030.

²³ Toluene purity is determined by subtracting the sum of the hydrocarbon impurities and water content from 100 %. Determine the hydrocarbon impurities by Test Method D 2360. Determine water content by Test Method D 1744. Peroxide Number shall be determined in accordance with Test Method D 3703.

flywheel in accordance with the instructions of the manufacturer.

10.2.3 *Valve Timing*—The engine uses a four-stroke cycle with two crankshaft revolutions for each complete combustion cycle. The two critical valve events are those that occur near tdc; intake valve opening and exhaust valve closing. See Annex A4 for camshaft timing and valve lift measurement procedures.

10.2.3.1 Intake valve opening shall occur $10.0 \pm 2.5^\circ$ after-top-dead-center (atdc) with closing at 34° after-bottom-dead-center (abdc) on one revolution of the crankshaft and flywheel.

10.2.3.2 Exhaust valve opening shall occur 40° before-bottom-dead-center (bbdc) on the second revolution of the crankshaft or flywheel, with closing at $15.0 \pm 2.5^\circ$ atdc on the next revolution of the crankshaft and flywheel.

10.2.4 *Valve Lift*—Intake and exhaust cam lobe contours, while different in shape, shall have a contour rise of 0.246 to 0.250 in. (6.248 to 6.350 mm) from the base circle to the top of the lobe. The resulting valve lift shall be 0.238 ± 0.002 in. (6.045 ± 0.05 mm). See Annex A4 for camshaft timing and valve lift measurement procedures.

10.2.5 *Intake Valve Shroud*—The intake valve has a 180° shroud or protrusion just inside the valve face to direct the incoming fuel-air charge and increase the turbulence within the combustion chamber. This valve stem is drilled for a pin, which is restrained in a valve guide slot, to prevent the valve from rotating and thus maintain the direction of swirl. The valve shall be assembled in the cylinder, with the pin aligned in the valve guide, so that the shroud is toward the spark plug side of the combustion chamber and the swirl is directed in a counterclockwise direction if it could be observed from the top of the cylinder.

10.2.6 *Carburetor Venturi*—The venturi throat size is dependent on the altitude of the location where the CFR engine is installed. Select the proper venturi in accordance with Table 1.

10.2.6.1 For CFR engines located at altitudes close to where venturi size is designated to change, select whichever venturi size results in minimum bias when rating TSF blends in accordance with the requirements of Section 11.

10.3 *Assembly Settings and Operating Conditions:*

10.3.1 *Direction of Engine Rotation*—Clockwise rotation of the crankshaft when observed from the front of the engine.

10.3.2 *Valve Clearances:*

10.3.2.1 *Engine Stopped and Cold*—Clearance between the valve stem and valve rocker half-ball, set upon assembly before the engine is operated can provide the controlling engine running and hot clearance. With the engine at tdc on the compression stroke, the appropriate cold clearances are as follows:

Intake valve	0.004 in. (0.075 mm)
Exhaust valve	0.014 in. (0.330 mm)

These clearances should ensure that both valves have sufficient clearance to cause valve seating during engine warmup. The adjustable-length valve push-rods shall be set so that the valve rocker adjusting screws have adequate travel to permit the final clearance setting.

10.3.2.2 *Engine Running and Hot*—The clearance for both intake and exhaust valves shall be set to 0.008 ± 0.001 in. (0.20 ± 0.025 mm), measured under standard operating conditions with the engine running at equilibrium conditions on a 90 O.N. PRF blend.

10.3.3 *Oil Pressure*—172 to 207 kPa (25 to 30 psi). See Annex A4, for the procedure to adjust crankcase lubricating oil pressure.

10.3.4 *Oil Temperature*— $57 \pm 8^\circ\text{C}$ ($135 \pm 15^\circ\text{F}$).

10.3.5 *Cylinder Jacket Coolant Temperature*— $100 \pm 1.5^\circ\text{C}$ ($212 \pm 3^\circ\text{F}$) constant within $\pm 0.5^\circ\text{C}$ ($\pm 1^\circ\text{F}$) during a rating.

10.3.6 *Intake Air Temperature*— $38 \pm 2.8^\circ\text{C}$ ($100 \pm 5^\circ\text{F}$).

10.3.7 *Intake Mixture Temperature*— $149 \pm 1^\circ\text{C}$ ($300 \pm 2^\circ\text{F}$) maintained within 1°C ($\pm 2^\circ\text{F}$) during a rating. If intake MIXT tuning is used to qualify the engine as fit-for-use, the temperature selected shall be between 141°C (285°F) and 163°C (325°F) and this temperature shall then be maintained within $\pm 1^\circ\text{C}$ ($\pm 2^\circ\text{F}$) during a rating.

10.3.7.1 The intake MIXT required to qualify the engine in each TSF blend O.N. range shall also be used for rating all sample fuels in that O.N. range during an operating period.

10.3.8 *Intake Air Humidity*—0.00356 to 0.00712 kg water per kg (25 to 50 grains of water per lb) of dry air.

10.3.9 *Cylinder Jacket Coolant Level:*

10.3.9.1 *Engine Stopped and Cold*—Treated water/coolant added to the cooling condenser: Cylinder jacket to a level just observable in the bottom of the condenser sight glass will typically provide the controlling engine running and hot operating level.

10.3.9.2 *Engine Running and Hot*—Coolant level in the condenser sight glass shall be within ± 1 cm (± 0.4 in.) of the LEVEL HOT mark on the coolant condenser.

10.3.10 *Engine Crankcase Lubricating Oil Level:*

10.3.10.1 *Engine Stopped and Cold*—Oil added to the crankcase so that the level is near the top of the sight glass will typically provide the controlling engine running and hot operating level.

10.3.10.2 *Engine Running and Hot*—Oil level shall be approximately mid-position in the crankcase oil sight glass.

10.3.11 *Crankcase Internal Pressure*—As measured by a gage or manometer connected to an opening to the inside of the crankcase through a snubber orifice to minimize pulsations, the pressure shall be less than zero (a vacuum) and is typically from 25 to 150 mm (1 to 6 in.) of water less than atmospheric pressure. Vacuum shall not exceed 255 mm (10 in.) of water.

10.3.12 *Exhaust Back Pressure*—As measured by a gage or manometer connected to an opening in the exhaust surge tank or main exhaust stack through a snubber orifice to minimize pulsations, the static pressure should be as low as possible, but shall not create a vacuum nor exceed 255 mm (10 in.) of water differential in excess of atmospheric pressure.

TABLE 1 Carburetor Venturi Size for Various Laboratory Elevations

Altitude at Engine Location, ft (m)	Venturi Throat Diameter, in. (mm)	Typical Barometric Pressure Range, in. Hg (kPa)
Sea Level to 1600 (500)	$\frac{9}{16}$ (14.3)	31.0 to 28.0 (104.7 to 94.6)
1600 to 3300 (500 to 1000)	$\frac{19}{32}$ (15.1)	29.0 to 26.0 (97.9 to 87.8)
Higher than 3300 (1000)	$\frac{3}{4}$ (19.1)	27.0 and Less (91.2 and Less)

10.3.13 *Exhaust and Crankcase Breather System Resonance*—The exhaust and crankcase breather piping systems shall have internal volumes and be of such length that gas resonance does not result. See Appendix X2 for a suitable procedure to determine if resonance exists.

10.3.14 *Belt Tension*—The belts connecting the flywheel to the absorption motor shall be tightened, after an initial break-in, so that with the engine stopped, a 2.25-kg (5-lb) weight suspended from one belt halfway between the flywheel and motor pulley shall depress the belt approximately 12.5 mm (0.5 in.).

10.3.15 *Basic Rocker Arm Carrier Adjustment:*

10.3.15.1 *Basic Rocker-Arm Carrier Support Setting*—Each rocker arm carrier support shall be threaded into the cylinder so that the distance between the machined surface of the cylinder and the underside of the fork is 31 mm (1¹/₃₂in.).

10.3.15.2 *Basic Rocker Arm Carrier Setting*—With the cylinder positioned so that the distance between the underside of the cylinder and the top of the clamping sleeve is approximately 160 mm (5⁷/₈ in.), the rocker arm carrier shall be set horizontal before tightening the bolts that fasten the long carrier support to the clamping sleeve.

10.3.15.3 *Basic Rocker Arm Setting*—With the engine on tdc on the compression stroke, and the rocker arm carrier set at the basic setting, set the valve adjusting screw to approximately the mid-position in each rocker arm. Then adjust the length of the push rods so that the rocker arms shall be in the horizontal position.

10.3.16 *Basic Spark Setting*—26° btdc at a critical cylinder height, uncompensated for barometric pressure and indicated as a digital counter reading of 264 or a dial indicator reading of 0.825 in.

10.3.16.1 The digital timing indicator currently supplied with CFR engine units, or the graduated spark quadrant formerly supplied, shall be in proper working order and calibrated so that the time of ignition is correctly displayed with reference to the engine crankshaft.

10.3.16.2 *Basic Ignition Timer Control Arm Setting*—Adjust and set the length of the ignition control rod so that the centerline of the ignition control arm shall be horizontal at the specified cylinder height uncompensated for barometric pressure.

10.3.16.3 *Ignition Timer Basic Transducer to Rotor Vane Gap Setting*—0.08 to 0.13 mm (0.003 to 0.005 in.).

10.3.16.4 *Basic Spark Setting*—With the engine running and firing, position the ignition timer in the ignition timer control arm so that ignition occurs at 26° btdc as displayed on the digital timing indicator or spark quadrant. Tighten the control arm knurled clamping screw.

10.3.16.5 *Automatic Change Spark Timing Adjustment*—As cylinder height is adjusted during the determination of O.N., the spark timing is automatically changed and shall provide the characteristic given in Table 2.

10.3.17 *Spark Plug Gap*—0.51 ± 0.13 mm (0.020 ± 0.005 in.).

10.3.18 *Basic Cylinder Height Setting*—Thoroughly warm up the engine under essentially standard operating conditions. Shut the unit down, and check that the ignition is turned off and

TABLE 2 Variation in Spark Timing As Cylinder Height is Changed

Cylinder Height Digital Counter Reading (Uncompensated)	Cylinder Height Dial Indicator Reading (Uncompensated)	Spark Timing, °btdc
264	0.825	26
337	0.773	25
410	0.721	24
484	0.669	23
556	0.617	22
630	0.565	21
704	0.513	20
777	0.461	19
851	0.408	18
925	0.356	17
998	0.304	16
1072	0.252	15
1145	0.200	14

fuel cannot enter the combustion chamber. Install a calibrated compression pressure gage assembly on the engine, motor the engine, and adjust the cylinder height so that the unit produces the basic compression pressure prescribed by the relationships of Fig. 2, for the appropriate carburetor venturi and the prevailing barometric pressure.

10.3.18.1 Index the cylinder height measurement device(s) to the appropriate value uncompensated for barometric pressure, as follows:

Digital Counter Reading of 930
Dial Indicator Reading of 0.352 in.

10.3.18.2 Refer to Annex A4 for a detailed cylinder height indexing procedure.

10.3.19 *Fuel-Air Ratio*—The fuel-air ratio (mixture proportion) for each sample fuel and PRF involved in the determination of an O.N. result shall be that which maximizes the K.I.

10.3.19.1 Fuel-air ratio is a function of the effective fuel level in the vertical jet of the standard carburetor assembly and is typically indicated as the fuel level in the appropriate carburetor sight glass.

10.3.19.2 The fuel level that produces maximum K.I. shall be from 0.7 to 1.7 in., referenced to the centerline of the venturi. If necessary, change the carburetor horizontal jet size (or equivalent restrictive orifice device) to satisfy the fuel level requirement.

10.3.20 *Carburetor Cooling*—Circulate coolant through the coolant passages of the carburetor whenever there is evidence of premature vaporization in the fuel delivery passages. Release of hydrocarbon vapors from the sample fuel can result in uneven engine operation or erratic K.I. reading and is usually indicated by bubble formation or abnormal fluctuation of the fuel level in the sight glass.

10.3.20.1 *Coolant*—Water or a water/antifreeze mixture.

10.3.20.2 *Coolant Temperature*—The liquid coolant delivered to the carburetor coolant exchangers shall be cold enough to prevent excessive vaporization but not colder than 0.6°C (33°F) or warmer than 10°C (50°F).²⁴

10.3.21 *Instrumentation:*

10.3.21.1 *Knockmeter Reading Limits*—The operational range for K.I. readings on the knockmeter shall be from 20 to

²⁴ Refer to Research Report RR:D02-1006. Available from ASTM Headquarters.

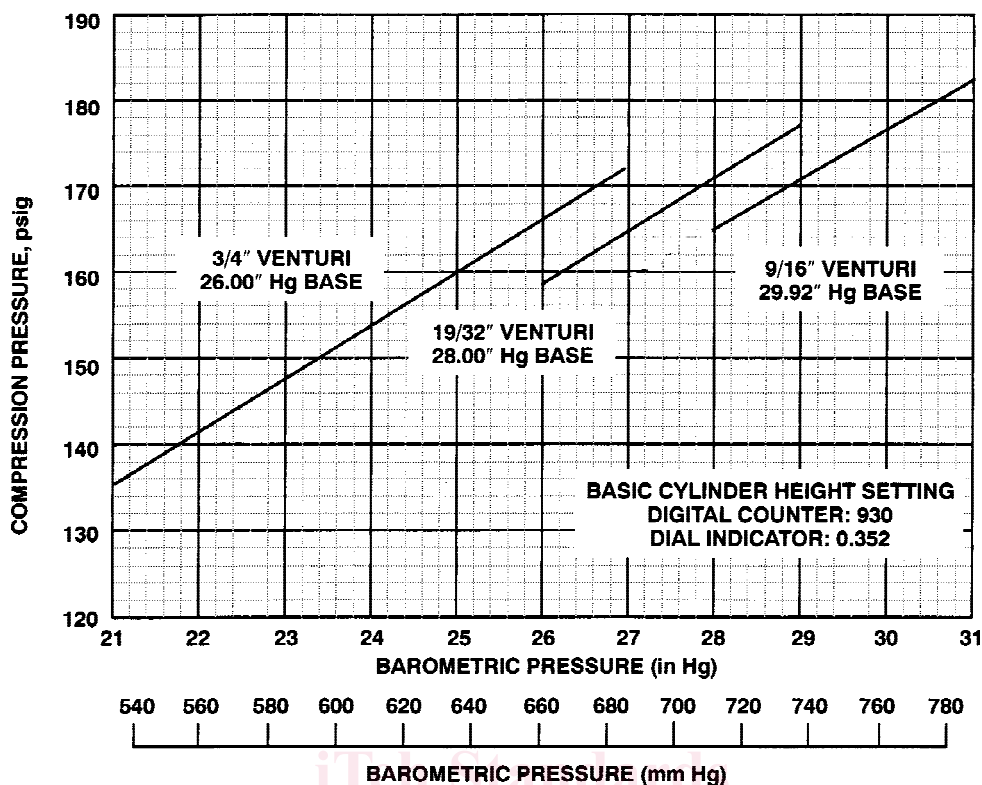

FIG. 2 Actual Compression Pressure for Setting Cylinder Height

80. K.I. is a nonlinear characteristic below 20 and the knockmeter has the potential to be nonlinear above 80.

10.3.21.2 *Detonation Meter Spread and Time Constant Settings*—Optimize these variables to maximize spread commensurate with reasonable K.I. signal stability. Refer to Procedure sections and Annex A4 for further details.

10.3.21.3 *Knockmeter Needle Mechanical Zero Adjustment*—With the detonation meter power switch in the OFF position, and the meter switch in the ZERO position, set the knockmeter needle to zero using the adjusting screw provided on the knockmeter face.

10.3.21.4 *Detonation Meter Zero Adjustment*—With the detonation meter power switch in the ON position, the meter switch in the ZERO position, the time constant switch on 3, and the meter reading and spread controls in their nominal operating positions, set the needle of the knockmeter to read zero using the detonation meter zero adjusting screw, which is to the left of the meter switch on the detonation meter and covered by a knurled cap.

11. Engine Standardization

11.1 *Unit Compliance*—Operate the properly commissioned knock test unit at temperature equilibrium and in compliance with the basic engine and instrument settings and standard operating conditions prescribed for this test method.

11.1.1 Operate the engine on fuel for approximately 1 h to ensure that all critical variables are stable. During the final 10 min of this warm-up period, operate the engine at a typical K.I. level.

11.2 *Fit-for-Use Qualification for Each Operating Period:*

11.2.1 Every sample fuel O.N. determination shall be performed using an engine that has been qualified as fit-for-use by

rating the appropriate TSF blend.

11.2.2 Qualify the engine using the appropriate TSF blends in accordance with the following conditions:

11.2.2.1 At least once during each 12 h period of rating.

11.2.2.2 After an engine has been shut down for more than 2 h.

11.2.2.3 After an engine has been operated at non-knocking conditions for more than 2 h.

11.2.2.4 After a barometric pressure change of more than 0.68 kPa (0.2 in. Hg) from that reading made at the time of the previous TSF blend rating for the specific O.N. range.

11.2.3 When either bracketing procedure is utilized to determine the TSF blend rating, establish standard K.I. using a PRF blend whose whole O.N. is closest to that of the O.N. accepted reference value of the selected TSF blend.

11.2.4 When either bracketing procedure is utilized to determine the TSF blend rating, set the cylinder height, compensated for the prevailing barometric pressure, to the guide table value for the O.N._{ARV} of the selected TSF blend.

11.2.5 When the compression ratio procedure is utilized to determine the TSF blend rating, first establish standard K.I. using the PRF blend whose whole O.N. is closest to that of the O.N._{ARV} of the selected TSF blend.

11.3 *Fit-for-Use Procedure 79.8 to 94.5 O.N.:*

11.3.1 Select the appropriate TSF blend(s) from Table 3 that are applicable for the O.N.s of the sample fuel ratings tested or to be tested during the operating period.

11.3.2 Rate the TSF blend using the standard intake MIXT of 149°C (300°F).

11.3.3 If the TSF blend rating is within the untuned rating tolerances of Table 3 for that TSF blend, the engine is fit for use

TABLE 3 TSF Blend O.N._{ARV}, Untuned Rating Tolerances and Sample Fuel Octane Number Range of Use^A

TSF Blend M.O.N. ARV	Untuned Rating Tolerance	TSF Blend Composition, vol %			Use for Sample Fuel M.O.N. Range
		Toluene	Isooctane	Heptane	
81.5 ^B	±0.3	74	0	26	79.6–83.5
85.2 ^B	±0.3	74	5	21	83.2–87.1
88.7 ^B	±0.3	74	10	16	86.8–90.8
92.6 ^C	±0.4	74	15	11	90.5–94.7

^A Request Research Reports RR:D02-1208 and RR:D02-1354 for M.O.N. accepted reference value (ARV) data.

^B M.O.N. accepted reference values determined by TCD93 worldwide program in 1993.

^C M.O.N. accepted reference values determined by National Exchange Group in 1986.

to rate sample fuels within the applicable O.N. range. Intake MIXT tuning is not required.

11.3.4 If the untuned TSF blend rating is more than 0.1 O.N. from the O.N._{ARV} in Table 3 for that TSF blend, it is permissible to adjust the intake MIXT slightly to obtain the O.N._{ARV} for that specific TSF blend.

11.3.5 If the TSF blend rating is outside the untuned rating tolerance of Table 3, adjust the intake MIXT, within prescribed limits, to obtain the O.N._{ARV} for that specific TSF blend.

11.3.5.1 The tuned intake MIXT shall be no lower than 141°C (285°F) nor higher than 163°C (325°F).

NOTE 1—A TSF blend rating change of 0.1 O.N. requires an intake mixture temperature adjustment of approximately 1°C (2°F). Increasing the temperature decreases the O.N.

11.3.5.2 If the temperature tuned TSF blend rating is within ± 0.1 O.N. of the O.N._{ARV} in Table 3, the engine is fit for use to rate sample fuels within the applicable O.N. range.

11.3.5.3 If the temperature tuned TSF blend rating is more than ±0.1 O.N. from the O.N._{ARV} in Table 3, the engine shall not be used for rating sample fuels having O.N. values within the applicable range, until the cause is determined and corrected.

11.4 *Fit-for-Use Procedure—Below 79.8 and Above 94.5 O.N.:*

11.4.1 Select the appropriate TSF blend(s) from Table 4 that are applicable for the O.N. values of the sample fuel ratings tested or to be tested during the operating period.

11.4.2 The rating tolerances of Table 4 are determined by multiplying the standard deviation of the data that established

TABLE 4 TSF Blend O.N._{ARV}, Rating Tolerances and Sample Fuel Octane Number Range of Use^A

TSF Blend M.O.N. ARV	Rating Tolerance	TSF Blend Composition, vol %			Use for Sample Fuel M.O.N. Range
		Toluene	Isooctane	Heptane	
58.0	±1.1	50	0	50	Below 62.3
66.9	±1.1	58	0	42	62.2–71.0
74.8	±1.0	66	0	34	70.7–76.7
78.2	±1.0	70	0	30	76.4–79.9
...
96.6	±1.2	74	20	6	94.4–98.4
99.8 ^B	±0.9	74	24	2	98.1–100.0
100.8	±1.3	74	26	0	Above 100.0

^A Request Research Report RR:D02-1208 for M.O.N. accepted reference value data.

^B M.O.N. accepted reference value determined by the National Exchange Group in 1986. M.O.N. accepted reference value for all other blends determined by the National Exchange Group and Institute of Petroleum in 1988/1989.

the O.N._{ARV} of the TSF blend and a statistical tolerance limit factor *K* for normal distributions. Using the standard deviation values for the TSF blend data sets of 100 or more values and *K* = 1.5, it is estimated that in the long run, in 19 cases out of 20, at least 87 % of the test engines would rate the TSF blend within the rating tolerances listed in Table 4.

11.4.3 Rate the TSF blend using the standard intake MIXT of 149°C (300°F). Temperature tuning is not permitted for these O.N. levels.

11.4.4 If the TSF blend rating is within the rating tolerance, the engine is fit for use to rate sample fuels having O.N. values within the applicable range for that TSF blend.

11.4.5 If the TSF blend rating is outside the rating tolerance, conduct a comprehensive examination to determine the cause and required corrections. It is expected that some engines will rate outside the rating tolerance, at one or more of the O.N. levels, under standard operating conditions. Control records or charts of these TSF blend ratings can be helpful to demonstrate the on-going performance characteristic of the unit.

11.5 *Checking Performance on Check Fuels:*

11.5.1 While engine standardization is dependent solely on TSF blend determinations, further rating using Check Fuels can provide additional credibility. Regular testing of Check Fuels and the use of standard quality control charting provide the means to document the overall effectiveness of the engine and operating personnel.

11.5.1.1 Test one or more Check Fuels.

11.5.1.2 Compare the octane rating obtained for the Check Fuel to the Check Fuel O.N._{ARV}.

11.5.1.3 Update the selected quality control charts to be maintained for the specific engine.

11.5.1.4 Interpret the performance depicted on the control charts in a timely manner so that investigation and corrective action can be taken if either a bias begins to develop or the variability of the engine begins to depreciate.

12. Test Variable Characteristics

12.1 *Cylinder Height Relationship to Octane Number—*Cylinder height, an indication of C.R., has a significant effect on fuels and their knocking characteristics. Every fuel has a critical C.R. at which knock begins to occur. As C.R. is increased above this critical threshold, the degree of knock, or severity of knock, increases. The Motor method of test compares sample fuels to PRF blends at a selected knock level termed standard K.I. Guide tables of cylinder height versus O.N. have been empirically determined using PRF blends.²⁵ They are based on the concept that the K.I. at all O.N. values is constant as detected by the knock measuring instrumentation. Because this test method utilizes three different carburetor venturi sizes, tables specific to each venturi size have been established. Fig. 3 illustrates the slightly nonlinear relationship between Motor O.N. and cylinder height expressed as digital counter reading. Specific guide tables in terms of both digital counter reading and dial indicator reading for each of the three

²⁵ Detonation meter guide tables were generated by setting the cylinder height to the value for the former bouncing pin instrumentation value at 85 O.N. and then using that K.I. as the reference for determining the cylinder height required for PRF blends over the range from 40 to 100 O.N.

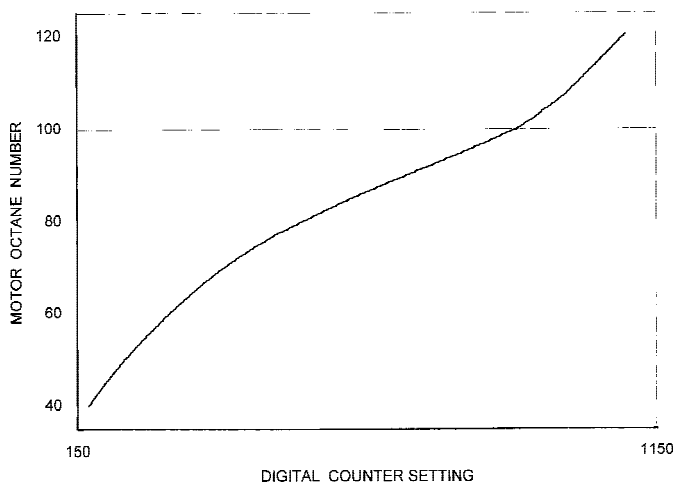

FIG. 3 Motor O.N. Versus Digital Counter Reading Characteristic

carburetor venturi sizes are in Annex A6 (see Table A6.1 and Table A6.8).

12.2 Barometric Pressure Compensation of Cylinder Height—O.N. values determined by this test method are referenced to standard barometric pressure of 760 mm (29.92 in.) of Hg. Changes in barometric pressure affect the level of knock because the density of the air consumed by the engine is altered. To compensate for a prevailing barometric pressure that is different from standard, the cylinder height is offset so that the K.I. will match that of an engine at standard barometric pressure. For lower than standard barometric pressure conditions, the cylinder height is changed to increase the engine C.R. and thus the knocking level. For higher than standard barometric pressure conditions, the cylinder height is changed to lower C.R. The changes in either digital counter reading or dial indicator reading to compensate for barometric pressure are listed in Annex A6 (see Tables A6.9 and A6.10).

12.2.1 Digital Counter Applications—The digital counter has two indicating counters. The top counter is directly connected to the worm shaft, which rotates the worm wheel that raises or lowers the cylinder in the clamping sleeve. It is the uncompensated digital counter reading. The lower counter can be disengaged from the upper counter for the purpose of off-setting its reading and thus establish the differential or compensation for prevailing barometric pressure. With the differential set, the two counters can be engaged to move together with the lower counter indicating the measure of cylinder height compensated to standard barometric pressure.

12.2.1.1 Digital counter readings decrease as cylinder height is raised and increase as cylinder height is lowered.

12.2.1.2 To index the digital counter unit, position the selector knob to any setting other than 1, change the cylinder height in the proper direction to compensate for the prevailing barometric pressure as given in Annex A6 (see Tables A6.9 and A6.10) so that the lower indicating counter is offset from the upper indicating counter by the amount of the compensation.

12.2.1.3 For barometric pressures lower than 760 mm (29.92 in.) of Hg, the lower indicating counter shall be less than the upper counter. For barometric pressures higher than 760 mm (29.92 in.) of Hg, the lower indicating counter shall be higher than the upper counter.

12.2.1.4 After adjusting to the correct counter readings, reposition the selector knob to 1 so that both indicating counters change when cylinder height changes are made. Check that the proper differential prevails as changes in cylinder height are made.

12.2.1.5 The lower indicating counter represents the measure of cylinder height at standard barometric pressure and is utilized for all comparisons with the values in the guide tables.

12.2.2 Dial Indicator Applications—The dial indicator is installed in a bracket on the side of the cylinder clamping sleeve so that the movable spindle contacts an anvil screw, positioned in a bracket mounted on the cylinder. As the cylinder is raised or lowered, the dial indicator reading measures the cylinder height in thousandths of an inch of travel. When indexed, the dial indicator reading is a measure of cylinder height for engines operating at standard barometric pressure. If the prevailing barometric pressure is other than 760 mm (29.92 in.) of Hg, correct the actual dial indicator reading so that it is compensated to standard barometric pressure. Compensated dial indicator readings apply whenever the reading is pertinent during the rating of sample fuels or when calibrating the engine using PRF blends.

12.2.2.1 Dial indicator readings decrease as cylinder height is lowered and increase as cylinder height is raised.

12.3 Engine Calibration at the Guide Table Cylinder Height—Calibrate the engine to produce standard K.I. at an O.N. level where sample fuels are expected to rate.

12.3.1 Prepare a PRF blend of the selected O.N. and introduce it to the engine.

12.3.2 Set the cylinder height to the appropriate guide table value (compensated for barometric pressure) for the O.N. of the PRF blend.

12.3.3 Determine the fuel level for maximum K.I.

12.3.4 Adjust the meter reading dial of the detonation meter so that the knockmeter reading is 50 ± 2 divisions.

12.4 Fuel-Air Ratio Characteristic—With the engine operating at a cylinder height that causes knock, variation of the fuel-air mixture has a characteristic effect, typical for all fuels. The peaking or maximizing knock characteristic is illustrated in Fig. 4. This test method specifies that each sample fuel and PRF shall be operated at the mixture condition that produces the maximum K.I. The CFR engine carburetor, utilizing a single vertical jet, provides a simple means to monitor a

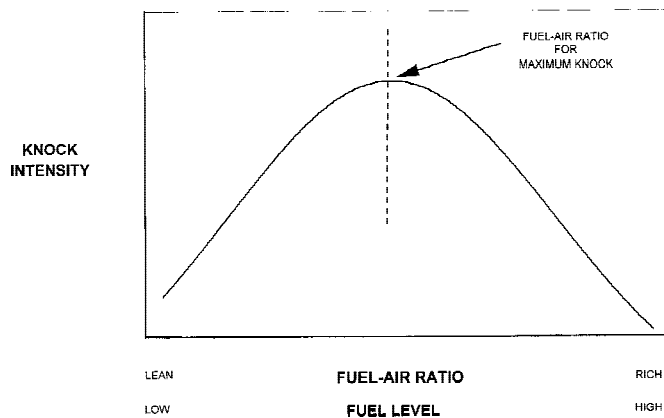

FIG. 4 Typical Effect of Fuel-Air Ratio on Knock Intensity

measure of fuel-air ratio using a sight glass that indicates the fuel level in the vertical jet. Fig. 5 illustrates the relationships of the components. Low fuel levels relate to lean mixtures and higher levels to rich mixtures. Fuel level changes are made to determine the level that produces the maximum knocking condition. To maintain good fuel vaporization, a restrictive orifice or horizontal jet is utilized so that the maximum knock condition occurs for fuel levels between 0.7 and 1.7 in. referenced to the centerline of the carburetor venturi. The mechanics for varying the fuel mixture can be accomplished using various approaches.

12.4.1 Fixed Horizontal Jet–Variable Fuel Level System—Fuel level adjustments are made by raising or lowering the float reservoir in incremental steps. Selection of a horizontal jet having the appropriate hole size establishes the fuel level at which a typical sample fuel achieves maximum knock.

12.4.2 Fixed Fuel Level–Variable Orifice System—A fuel reservoir, in which the fuel can be maintained at a prescribed constant level, supplies an adjustable orifice (special long-tapered needle valve) used in place of the horizontal jet. Fuel mixture is changed by adjustment of the needle valve. Typically, the constant fuel level selected is near the 1.0 level, which satisfies the fuel level specification and also provides good fuel vaporization.

12.4.3 Dynamic or Falling Level System—A fuel reservoir, filled to a higher level than that required for maximum K.I., delivers fuel through either a fixed bore or adjustable horizontal jet. With the engine firing, the fuel level falls as fuel is consumed. Fuel level changes automatically at a specifically selected constant rate that is established by the cross-sectional area of the fuel reservoir and associated sight glass assembly. Maximum K.I. is recorded as the fuel level passes through the critical level.

PROCEDURE A

13. Bracketing—Equilibrium Fuel Level

13.1 Check that all engine operating conditions are in compliance and equilibrated with the engine running on a

typical fuel at approximately standard K.I.

13.2 Perform engine fit-for-use testing utilizing a TSF blend applicable for the O.N. range in which sample fuels are expected to rate. If TSF blend temperature tuning is to be used, determine the proper intake MIXT required. Perform this rating in the same manner described below for a sample fuel except that the TSF blend shall be rated without carburetor cooling.

13.3 Establish standard K.I. by engine calibration using a PRF blend having an O.N. close to that of the sample fuels to be rated.

13.3.1 Set the cylinder height to the barometric pressure compensated value for the O.N. of the selected PRF.

13.3.2 Determine the fuel level for maximum K.I. and then adjust the detonation meter METER READING dial to produce a knockmeter reading of 50 ± 2 divisions.

13.3.3 Check that detonation meter SPREAD is maximized commensurate with satisfactory knockmeter stability.

13.3.4 Detonation meter spread set at 12 to 14 K.I. divisions per O.N. at the 90 O.N. level will typically provide suitably optimized spread settings for the range 80 to 103 O.N. without resetting. Refer to Annex A4.

13.4 Sample Fuel:

13.4.1 Introduce the sample fuel to the carburetor, purge the fuel system, and if applicable, the sight glass and float reservoir by opening and then closing the sight glass drain valve several times and observing that there are no bubbles in the clear plastic tubing between the float reservoir and the sight glass. (**Warning**—Sample fuel is extremely flammable and its vapors are harmful if inhaled. Vapors may cause flash fire. See Annex A1.)

13.4.2 Operate the engine on sample fuel.

13.4.3 Adjust the cylinder height to cause a mid-scale knockmeter reading.

13.4.4 Determine the fuel level for maximum K.I. One approach is to first lower the fuel level (float reservoir assembly) and then raise it in small increments (0.1 sight glass divisions or less) until the knockmeter reading peaks and begins to fall off. Reset the float reservoir to the fuel level that produces the maximum knockmeter reading.

13.4.5 Adjust the cylinder height so that the knockmeter reading is 50 ± 2 divisions.

13.4.6 Record the knockmeter reading.

13.4.7 Observe the cylinder height reading, compensated to standard barometric pressure, and using the appropriate guide table, determine the estimated O.N. of the fuel sample.

13.5 Reference Fuel No. 1:

13.5.1 Prepare a fresh batch of a PRF blend that has an O.N. estimated to be close to that of the sample fuel.

13.5.2 Introduce Reference Fuel No. 1 to the engine and, if applicable, purge the fuel lines in the same manner as noted for the sample fuel.

13.5.3 Position the fuel-selector valve to operate the engine on Reference Fuel No. 1 and perform the step-wise adjustments required for determining the fuel level for maximum K.I.

13.5.4 Record the equilibrium knockmeter reading for Reference Fuel No. 1.

13.6 Reference Fuel No. 2:

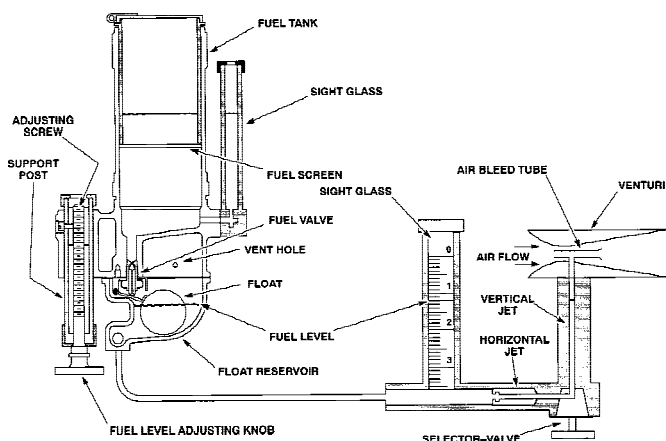

- Air flow through venturi is constant
- Raising fuel level richens F/A mixture
- Fuel level for maximum K.I. depends on horizontal jet size and fuel level
- Fuel level for maximum K.I. must be between 0.7 and 1.7
- Larger hole size in horizontal jet will lower maximum K.I. fuel level.

FIG. 5 CFR Engine Carburetor Assembly

13.6.1 Select another PRF blend that can be expected to result in a knockmeter reading that causes the readings for the two reference fuels to bracket that of the sample fuel.

13.6.2 The maximum permissible difference between the two reference fuels is dependent on the O.N. of the sample fuel. Refer to Table 5.

13.6.3 Prepare a fresh batch of the second PRF blend.

13.6.4 Introduce Reference Fuel No. 2 to the engine and, if applicable, purge the fuel lines in the same manner as noted for the sample fuel.

13.6.5 Position the fuel-selector valve to operate the engine on Reference Fuel No. 2 and perform the required step-wise adjustments for determining the fuel level for maximum K.I.

13.6.6 If the knockmeter reading for the sample fuel is bracketed by those of the two PRF blends, continue the test; otherwise try another PRF blend(s) until the bracketing requirement is satisfied.

13.6.7 Record the equilibrium knockmeter reading for Reference Fuel No. 2.

13.7 Repeat Readings:

13.7.1 Perform the necessary steps to obtain repeat knockmeter readings on the sample fuel, Reference Fuel No. 2, and finally Reference Fuel No. 1. For each fuel, be certain that the fuel level used is that for maximum K.I. and allow operation to reach equilibrium before recording the knockmeter readings. The fuel switching for the complete rating shall be as illustrated in Fig. 6.

13.7.2 Refer to Section 16 for detailed interpolation and calculation procedure.

13.7.3 The two knockmeter readings for the sample fuel and two for each of the PRF blends constitute a rating provided (1) the difference between the rating calculated from the first and second series of readings is no greater than 0.3 O.N., and (2) the average of the sample fuel knockmeter readings is between 45 and 55.

13.7.4 If the first and second series of knockmeter readings do not meet the criteria, a third series of readings may be obtained. The fuel switching order for this set shall be sample fuel, Reference Fuel No. 1, and finally Reference Fuel No. 2. The second and third series of knockmeter readings shall then constitute a rating provided the difference between the rating calculated from the second and third series of readings is no greater than 0.3 O.N., and the average of the last two sample fuel knockmeter readings is between 45 and 55.

13.8 Checking Guide Table Compliance:

13.8.1 Check that the cylinder height, compensated for barometric pressure, used for the rating is within the prescribed

TABLE 5 Maximum Permissible Bracketing PRF O.N. Differences

O.N. Range of Sample Fuel	Maximum Permissible O.N. Difference of PRF Blends
40 to 72	4.0
72 to 80	2.4
80 to 100	2.0
100.0 to 100.7	Use only 100.0 and 100.7 O.N. PRF blends
100.7 to 101.3	Use only 100.7 and 101.3 O.N. PRF blends
101.3 to 102.5	Use only 101.3 and 102.5 O.N. PRF blends
102.5 to 103.5	Use only 102.5 and 103.5 O.N. PRF blends
103.5 to 108.6	Use PRF blends 0.2 mL TEL/gal apart
108.6 to 115.5	Use PRF blends 0.5 mL TEL/gal apart
115.5 to 120.3	Use PRF blends 1.0 mL TEL/gal apart

KNOCKMETER READINGS

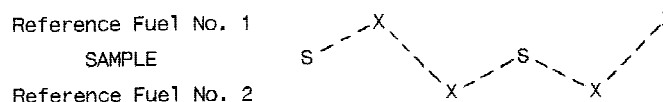

FIG. 6 Sample and Reference Fuel Reading Sequence

limits of the applicable guide table value of cylinder height for the sample fuel O.N. At all O.N. levels, the digital counter reading shall be within ± 20 of the guide table value. The dial indicator reading shall be within ± 0.014 in. of the guide table value.

13.8.2 If the cylinder height of the sample fuel rating is outside the guide table limit, repeat the rating after readjustment of the detonation meter to obtain standard K.I. using a PRF blend whose O.N. is close to that of the sample fuel.

13.9 Special Instructions for Sample Fuel Ratings Above 100 O.N.:

13.9.1 Knock characteristics become more erratic and unstable at octane levels above 100 for several reasons. Careful attention to the setting and adjustment of all variables is required to ensure that the rating is representative of the sample fuel quality.

13.9.2 If the sample fuel rating will be above 100 O.N., it is necessary to establish standard K.I. using an *isooctane* plus TEL PRF blend before sample fuel testing can continue. This may require more than one trial to select the appropriate leaded PRF (one of the two that bracket the sample fuel) and proper cylinder height. It will also necessitate adjustment of the detonation meter METER READING dial to obtain a knockmeter reading of approximately 50 divisions. If the rating is between 100.0 and 100.7 O.N., use the *isooctane* plus 0.05 mL TEL PRF to establish standard K.I. At the higher O.N. levels, either of the specified leaded PRF blends for the particular O.N. range may be used for this purpose.

13.9.3 Refer to Table 5 when selecting the PRF blends for sample fuels that rate above 100 O.N. Use only the specified PRF pairs for sample fuels that rate in the O.N. ranges 100.0 to 100.7; 100.7 to 101.3; 101.3 to 102.5; and 102.5 to 103.5.

13.9.4 Check that detonation meter spread is maintained as large as possible despite the fact that knockmeter readings will vary considerably and make selection of an average reading tedious.

PROCEDURE B

14. Bracketing—Dynamic Fuel Level:

14.1 *Applicable O.N. Rating Range*—This procedure shall only apply for ratings within the range from 80 to 100 O.N.

14.2 Check that all engine operating conditions are in compliance and equilibrated with the engine running on a typical fuel at approximately standard K.I.

14.3 Perform engine fit-for-use testing utilizing a TSF blend applicable for the O.N. range in which sample fuels are expected to rate. If TSF blend temperature tuning is to be used, determine the proper intake MIXT required. Perform this rating in the same manner described below for a sample fuel except that the TSF blend shall be rated without carburetor cooling.

14.4 Establish standard K.I. by engine calibration using a PRF blend having an O.N. close to that of the sample fuels to be rated.

14.4.1 Set the cylinder height to the barometric pressure compensated value for the O.N. of the selected PRF.

14.4.2 Determine the fuel level for maximum K.I. and then adjust the detonation meter METER READING dial to produce a knockmeter reading of 50 ± 2 divisions.

14.4.3 Check that detonation meter SPREAD is maximized commensurate with satisfactory knockmeter stability.

14.4.4 Detonation meter spread set at 12 to 14 K.I. divisions per O.N. at the 90 O.N. level will typically provide suitably optimized spread settings for the range 80 to 100 O.N. without resetting. Refer to Annex A4.

14.5 *Sample Fuel:*

14.5.1 Introduce the sample fuel to an empty fuel reservoir. Purge the fuel line, sight glass, and fuel reservoir by opening and then closing the sight glass drain valve several times and observing that there are no bubbles in the clear plastic tubing between the fuel reservoir and the sight glass. Top off the level so that the fuel level is at approximately 0.4 in the sight glass. Where experience demonstrates the critical maximum K.I. occurs near a specific fuel level, filling to a level 0.3 above the typical level is acceptable. (**Warning**—Sample fuel is extremely flammable and its vapors are harmful if inhaled. Vapors may cause flash fire. See Annex A1.)

14.5.2 Position the fuel-selector valve to operate the engine on the sample fuel and observe that the fuel level begins to fall in the sight glass.

14.5.3 When applying this falling level technique, stop the sequence by switching to another fuel when the K.I. reading passes its maximum value and decreases approximately ten divisions. Closely monitor each falling fuel level sequence to ensure the engine is always supplied with fuel and that knocking conditions prevail for a high proportion of rating time to maintain operating temperature conditions.

14.5.4 If the K.I. reading changes significantly from mid-scale, adjust the cylinder height to bring the engine close to the standard K.I. condition.

NOTE 2—Proficiency in making this initial adjustment of cylinder height is achieved with experience.

14.5.5 Refill the fuel reservoir to the appropriate rich mixture sight glass level for each successive repetition of the trial-and-error process.

14.5.6 After the cylinder height is approximately determined, it may be necessary to make a final adjustment to ensure that (1) the fuel level for maximum K.I. occurs at a sight glass level within the critical range from 0.7 to 1.7 in. and (2) the maximum K.I. reading is between 45 and 55 divisions.

14.5.7 Record the maximum K.I. reading, or if a K.I. recorder is being used, mark the trace to indicate the sample identification and highlight the maximum reading.

14.5.8 Observe the cylinder height reading, compensated to standard barometric pressure, and using the appropriate guide table, determine the estimated O.N. of the sample fuel.

14.6 *Reference Fuel No. 1:*

14.6.1 Prepare a fresh batch of a PRF blend that has an O.N. estimated to be close to that of the sample fuel.

14.6.2 Introduce Reference Fuel No. 1 to one of the unused fuel reservoirs, taking care to purge the fuel line, sight glass, and fuel reservoir in the same manner as noted for the sample fuel.

14.6.3 Position the fuel-selector valve to operate the engine on Reference Fuel No. 1 and record, or mark the recorder tracing, to indicate the maximum K.I. reading that occurs as the fuel level falls. Care shall be taken to observe that the maximum K.I. condition occurs at a fuel level within the specified 0.7 to 1.7 in. range.

14.7 *Reference Fuel No. 2:*

14.7.1 Select another PRF blend that can be expected to result in a maximum K.I. reading that causes the readings for the two reference fuels to bracket that of the sample fuel.

14.7.2 The maximum permissible difference between the two reference fuels is dependent on the O.N. of the sample fuel. Refer to Table 5.

14.7.3 Prepare a fresh batch of the selected PRF blend.

14.7.4 Introduce Reference Fuel No. 2 to one of the unused fuel reservoirs, taking care to purge the fuel line, sight glass, and fuel reservoir in the same manner as noted for the sample fuel.

14.7.5 Position the fuel-selector valve to operate the engine on Reference Fuel No. 2 and record, or mark the recorder tracing, to indicate the maximum K.I. reading which occurs as the fuel level falls. Care shall be taken to observe that the maximum K.I. condition occurs at a fuel level within the specified 0.7 to 1.7 in. range.

14.7.6 If the maximum K.I. reading for the sample fuel is bracketed by those of the two reference fuel blends, continue the rating; otherwise try another reference fuel blend(s) until the bracketing requirement is satisfied.

14.8 *Repeat Readings:*

14.8.1 Perform the necessary steps to obtain repeat K.I. readings on the sample fuel, Reference Fuel No. 2, and finally Reference Fuel No. 1. The fuel switching for the complete rating shall be as illustrated in Fig. 6.

14.8.2 Refer to Section 16 for detailed interpolation and calculation procedure.

14.8.3 The two maximum K.I. readings for the sample fuel and two for each of the PRF blends constitute a rating provided (1) the difference between the rating calculated from the first and second series of readings is no greater than 0.3 O.N., and the (2) average of the sample fuel K.I. readings is between 45 and 55.

14.8.4 If the first and second series of K.I. readings do not meet the criteria, a third series of readings may be obtained. The fuel switching order for this set shall be sample fuel, Reference Fuel No. 1, and finally Reference Fuel No. 2. The second and third series of maximum K.I. readings shall then constitute a rating provided the difference between the rating calculated from the second and third series of readings is no greater than 0.3 O.N., and the average of the last two sample fuel K.I. readings is between 45 and 55.

14.9 *Checking Guide Table Compliance:*

14.9.1 Check that the cylinder height, compensated for barometric pressure, used for the rating is within the prescribed limits of the applicable guide table value of cylinder height for