

SLOVENSKI STANDARD

SIST EN 3646-001:2016

01-marec-2016

Nadomešča:

SIST EN 3646-001:2009

Aeronavtika - Konektorji, električni, okrogli, bajonetno sklapljanje, stalna delovna temperatura 175 °C ali 200 °C - 001. del: Tehnična specifikacija

Aerospace series - Connectors, electrical, circular, bayonet coupling, operating temperature 175 °C or 200 °C continuous - Part 001: Technical specification

Luft- und Raumfahrt - Elektrische Rundsteckverbinder mit Bajonettkupplung, Betriebstemperatur 175 °C oder 200 °C konstant - Teil 001: Technische Lieferbedingungen

[SIST EN 3646-001:2016](#)

Série aérospatiale - Connecteurs électriques circulaires à accouplement par baïonnettes, température d'utilisation 175 °C ou 200 °C continu - Partie 001: Spécification technique

Ta slovenski standard je istoveten z: EN 3646-001:2015

ICS:

31.220.10	Vtiči in vtičnice, konektorji	Plug-and-socket devices. Connectors
49.060	Letalska in vesoljska električna oprema in sistemi	Aerospace electric equipment and systems

SIST EN 3646-001:2016

en,fr,de

iTeh STANDARD PREVIEW
(standards.iteh.ai)

[SIST EN 3646-001:2016](#)

<https://standards.iteh.ai/catalog/standards/sist/6ad3e63b-8b11-472c-ae77-3a3b22496fd9/sist-en-3646-001-2016>

EUROPEAN STANDARD

EN 3646-001

NORME EUROPÉENNE

EUROPÄISCHE NORM

November 2015

ICS 49.060

Supersedes EN 3646-001:2007

English Version

Aerospace series - Connectors, electrical, circular, bayonet coupling, operating temperature 175 °C or 200 °C continuous - Part 001: Technical specification

Série aérospatiale - Connecteurs électriques circulaires à accouplement par baïonnettes, température d'utilisation 175 °C ou 200 °C continu - Partie 001: Spécification technique

Luft- und Raumfahrt - Elektrische Rundsteckverbinder mit Bajonettkupplung, Betriebstemperatur 175 °C oder 200 °C konstant - Teil 001: Technische Lieferbedingungen

This European Standard was approved by CEN on 8 June 2015.

CEN members are bound to comply with the CEN/CENELEC Internal Regulations which stipulate the conditions for giving this European Standard the status of a national standard without any alteration. Up-to-date lists and bibliographical references concerning such national standards may be obtained on application to the CEN-CENELEC Management Centre or to any CEN member.

This European Standard exists in three official versions (English, French, German). A version in any other language made by translation under the responsibility of a CEN member into its own language and notified to the CEN-CENELEC Management Centre has the same status as the official versions.

CEN members are the national standards bodies of Austria, Belgium, Bulgaria, Croatia, Cyprus, Czech Republic, Denmark, Estonia, Finland, Former Yugoslav Republic of Macedonia, France, Germany, Greece, Hungary, Iceland, Ireland, Italy, Latvia, Lithuania, Luxembourg, Malta, Netherlands, Norway, Poland, Portugal, Romania, Slovakia, Slovenia, Spain, Sweden, Switzerland, Turkey and United Kingdom.



EUROPEAN COMMITTEE FOR STANDARDIZATION
COMITÉ EUROPÉEN DE NORMALISATION
EUROPÄISCHES KOMITEE FÜR NORMUNG

CEN-CENELEC Management Centre: Avenue Marnix 17, B-1000 Brussels

Contents		Page
European foreword.....		3
Introduction		4
1	Scope	5
2	Normative references	5
3	Terms and definitions	5
4	Description	6
5	Design	7
6	Definition drawings and masses.....	8
7	Tests.....	31
8	Quality assurance.....	42
9	Designation and marking.....	47
10	Delivery conditions	47
11	Packaging	47
12	Storage	47

[SIST EN 3646-001:2016](https://standards.iteh.ai/catalog/standards/sist/6ad3e63b-8b11-472c-ae77-3a3b22496fd9/sist-en-3646-001-2016)
<https://standards.iteh.ai/catalog/standards/sist/6ad3e63b-8b11-472c-ae77-3a3b22496fd9/sist-en-3646-001-2016>

European foreword

This document (EN 3646-001:2015) has been prepared by the Aerospace and Defence Industries Association of Europe - Standardization (ASD-STAN).

After enquiries and votes carried out in accordance with the rules of this Association, this Standard has received the approval of the National Associations and the Official Services of the member countries of ASD, prior to its presentation to CEN.

This European Standard shall be given the status of a national standard, either by publication of an identical text or by endorsement, at the latest by May 2016, and conflicting national standards shall be withdrawn at the latest by May 2016.

Attention is drawn to the possibility that some of the elements of this document may be the subject of patent rights. CEN [and/or CENELEC] shall not be held responsible for identifying any or all such patent rights.

This document supersedes EN 3646-001:2007.

According to the CEN-CENELEC Internal Regulations, the national standards organizations of the following countries are bound to implement this European Standard: Austria, Belgium, Bulgaria, Croatia, Cyprus, Czech Republic, Denmark, Estonia, Finland, Former Yugoslav Republic of Macedonia, France, Germany, Greece, Hungary, Iceland, Ireland, Italy, Latvia, Lithuania, Luxembourg, Malta, Netherlands, Norway, Poland, Portugal, Romania, Slovakia, Slovenia, Spain, Sweden, Switzerland, Turkey and the United Kingdom.

[SIST EN 3646-001:2016
https://standards.iteh.ai/catalog/standards/sist/6ad3e63b-8b11-472c-ae77-3a3b22496fd9/sist-en-3646-001-2016](https://standards.iteh.ai/catalog/standards/sist/6ad3e63b-8b11-472c-ae77-3a3b22496fd9/sist-en-3646-001-2016)

EN 3646-001:2015 (E)**Introduction**

This family of connectors is derived from MIL-DTL-26482, series 2, the NAS 1599 bayonet connector with which it is intermateable and which uses AS-39029 for the contacts. It is particularly suitable for use on aircraft applying EN 2282.

These connectors are distinguishable from MIL-DTL-26482 and NAS 1599 by:

- being of a lower mass;
- having reduced dimensions;
- accepting smaller cables.

iTeh STANDARD PREVIEW
(standards.iteh.ai)

[SIST EN 3646-001:2016](https://standards.iteh.ai/catalog/standards/sist/6ad3e63b-8b11-472c-ae77-3a3b22496fd9/sist-en-3646-001-2016)

<https://standards.iteh.ai/catalog/standards/sist/6ad3e63b-8b11-472c-ae77-3a3b22496fd9/sist-en-3646-001-2016>

1 Scope

This standard specifies the general characteristics, the conditions for qualification, acceptance and quality assurance, as well as the test programmes and groups for bayonet coupling circular connectors, intended for use in an operating temperature range of -65 °C to 175 °C or 200 °C continuous according to the class and models.

2 Normative references

The following documents, in whole or in part, are normatively referenced in this document and are indispensable for its application. For dated references, only the edition cited applies. For undated references, the latest edition of the referenced document (including any amendments) applies.

EN 2266-002, *Aerospace series — Cables, electrical, for general purpose — Operating temperatures between -55 °C and 200 °C — Part 002: General*

EN 2282, *Aerospace series — Characteristics of aircraft electrical supplies*

EN 2591-100*, *Aerospace series — Elements of electrical and optical connection — Test methods — Part 100: General*

EN 3155-001, *Aerospace series — Electrical contacts used in elements of connection — Part 001: Technical specification*

EN 3197, *Aerospace series — Installation of aircraft electrical and optical interconnection systems*

EN 3646-002, *Aerospace series — Connectors, electrical, circular, bayonet coupling, operating temperature 175 °C or 200 °C continuous — Part 002: Specification of performance and contact arrangements*

EN 9133, *Aerospace series — Quality management systems — Qualification procedure for aerospace standard parts*

ISO 263, *Inch screw threads — General plan and selection for screws, bolts and nuts — Diameter range 0,06 to 6 in*

ISO 4524-1, *Metallic coatings — Test methods for electrodeposited gold and gold alloy coatings — Part 1: Determination of coating thickness*

AS 39029, *Contacts, electrical connector, general specification for¹⁾*

MIL-DTL-26482H, *Connector, electrical, (circular, Miniature, quick disconnect, environment resisting), receptacles and plugs, general specification for²⁾*

MIL-HDBK-454N, *General guidelines for electronic equipment²⁾*

NAS 1599, *(Inactive) Connectors, general purpose, electrical, miniature circular, environment resisting, 200 °C maximum temperature³⁾*

3 Terms and definitions

For the purposes of this document, the terms and definitions given in EN 2591-100 apply.

* And all parts quoted in this standard.

1) Published by: Society of Automotive Engineers, Inc. (SAE), 400 Commonwealth Drive, Warrendale, PA 15096-0001, USA (<http://www.sae.org/>).

2) Published by: Department of Defense (DOD), the Pentagon, Washington, DC 20301, USA (<http://www.defenselink.mil/>).

3) Published by: Aerospace Industries Association of America, Inc. (AIA), 1250 Eye Street, NW; Suite 1100, Washington, DC 20005, USA (<http://www.aia-aerospace.org>).

EN 3646-001:2015 (E)**4 Description****4.1 General**

Different variants of materials, housings and contact arrangements are provided according to the models depending on the service conditions.

These connectors use crimp or solder contacts of size 20, size 16 and size 12.

The receptacles and plugs contain either male contacts or female contacts.

The contacts fitted in the model Y receptacles are exclusively of the male non removable solder type.

The connectors are polarized by means of keyways and keys. When all the male contacts are in place, polarization is obtained by different angular positions of the insulator in relation to the main slot or locking key and shall occur before the coupling ring can carry out its function.

The visual check of coupling is obtained by viewing the locking pins through the inspection holes in the coupling ring of the plug.

4.2 Receptacle

The receptacle may be attached by:

- square flange;
- nut, with sealing by O-ring at the attachment;
- round soldered or brazed flange for model Y connectors.

The receptacle contains five keyways in which the keys of the plug engage. The main keyway is fixed and is wider than the others. Polarization is ensured by the different angular positions of the inserts.

4.3 Plug

The plug contains five keys which engage in the keyways of the receptacle. The main key is wider than the others. Polarization is ensured by the different angular position of the inserts.

The coupling ring permanently fitted on the plug enables the connectors to be coupled and uncoupled. The internal guides of the coupling ring may be treated with a suitable lubricant compatible with the performance required in this standard.

The plug of models RS and WS is fitted with a grounding spring device ensuring electrical continuity between the coupled connector housings.

4.4 Materials and surface treatment**4.4.1 General**

When different metals are in close contact, adequate protection against corrosion shall be used for the electromotive force of the cell not to exceed 0,25 V (see EN 3197).

4.4.2 Housings

The material of the housing for the connectors and for the fittings may either be passivated stainless steel or light alloy protected against corrosion by nickel, black anodized or cadmium plating (see EN 3646-002).

4.4.3 Contacts

Unless otherwise specified, the contacts shall be in ferrous alloy for models Y and in copper alloy for the other models.

They shall be gold-plated on an appropriate undercoat. Selective protection is authorized provided that it is sufficient to ensure that performance is respected.

Measurement of the thickness of the protective treatment shall be effected in accordance with ISO 4524-1.

4.4.4 Non-metallic materials

The materials used for insert, seals and grommets shall have a hardness and mechanical and electrical characteristics consistent with the required use.

5 Design

5.1 Housings

The connector housings shall be in one unit. At the rear of the connector housing there shall be either three teeth at 120° intervals or teeth around the entire periphery. These teeth shall accommodate cable outlets or other fittings. The receptacle shall furthermore be fitted with an O-ring seal for sealing the coupled housings.

Receptacles for attachment by nut shall contain an O-ring seal. The nut shall have holes for the passage of locking wire.

The threads shall conform to ISO 263.

The coupling ring shall be designed so that the male and female contacts engage when it is turned clockwise and disengaged when it is turned counter-clockwise. The coupling ring shall be knurled.

The cable outlets shall compress the connector grommets without distorting it.

5.2 Inserts

The insert carrying the male and female contacts shall be in hard material and have a cross section and radii such that no cracks, flaking or breaks can occur in normal operation.

The insert for contacts shall be non-removable; it shall be mechanically held in the housing. Sealing shall be provided between the housing and insert.

The front face of the insert shall be such that sealing is ensured when the connectors are coupled. The interfacial seal of the insert of the male contacts shall be bonded on the hard insert.

The grommet shall permit sealing for all cable diameters indicated in EN 3646-002 and shall not be removable.

The mechanical contacts retention system shall be integrated in the hard insert.

The design of non-hermetic connectors shall permit individual installation of the contacts without removal of the insert or grommet. Insertion and removal of the contacts shall be from the rear, with the tools specified in the contact product standards.

6 Definition drawings and masses

The general dimensions and the masses of receptacles, plugs and protective covers are given in the product standards.

6.1 Receptacle mating dimensions

The mating dimensions of receptacles are shown in Figure 1 and details A and B as well as in Table 1, Table 2 and Table 3.

Dimensions and tolerances are in millimetres.

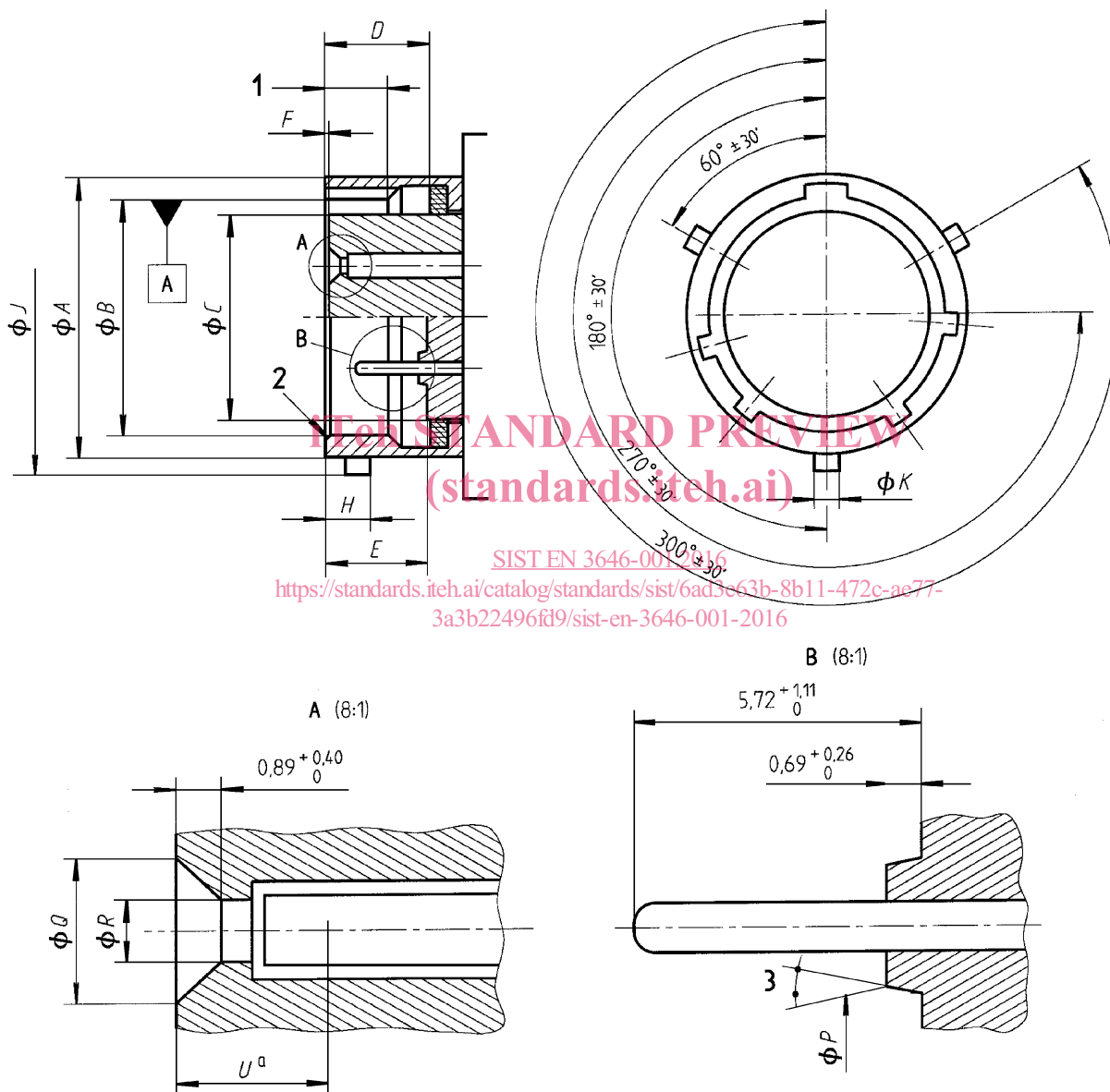

Key

- 1 Shells 08 to 18: 5 min.
Shells 20 to 24: 6 min.
- 2 Radius or chamfer 0,2 mm to 0,381 mm
- 3 7°30' to 11°30'
- a Position of point of electrical contact

Figure 1 — Receptacle

Table 1 — Receptacle — Mating dimensions

Housing size	A + 0,02 - 0,13	B + 0,13 - 0,02	C max.	D	E	F	H $\pm 0,18$	J 0 - 0,4	K + 0,15 - 0,05
08	12,02	9,19	7,24	8,38 8,00	8,50 8,10	0,56 0,20	3,55	14,30	1,98
10	14,99	12,44	10,21					17,27	
12	19,05	15,41	13,11					21,82	
14	22,23	18,59	16,28					24,99	
16	25,40	21,76	19,46					28,14	
18	28,58	24,43	21,72					31,32	
20	31,75	27,61	24,89	9,98 9,60	10,10 9,70	2,13 1,78	34,49	3,18	
22	34,93	30,78	28,07				37,67		
24	38,10	33,96	31,22				40,89		4,38

Table 2 — Details A and B

Contact size	P	Q	R	U max.
20	2,29	2,44	1,50	3,68
	2,13 ^a	2,34 ^a		
16	2,84	3,00	2,06	3,94
	2,69	2,89		
12	3,66	3,81	2,84	3,94
	3,50	3,71		
	5,18	5,33	2,84	
	5,03	5,23	2,59	

^a See Table 3.

Table 3 — Reduced contact cavities

Housing size and contact arrangements	Reduced contact cavities
8 - 33	A, B, C
8 - 3A or 8 - 98	A, B, C
12 - 10	C, G
14 - 12	A, B, C, D, E, F, G, H
14 - 19	B, D, F, H, K, M
16 - 26	A, B, C, D, E, F, G, H, J, K, L, M, N, P, R
18 - 32	A, B, C, D, E, F, G, H, J, K, L, M, N, P, R, S, T
22 - 41	A, B, C, D, E, F, G, H, J, K, L, M, N, P, R, S, T, U, V, W, X, Y

EN 3646-001:2015 (E)

6.2 Plug mating dimensions

The mating dimensions of plugs are shown in Figure 2 and Figure 3 and in Table 4 and Table 5.

Dimensions and tolerances are in millimetres.

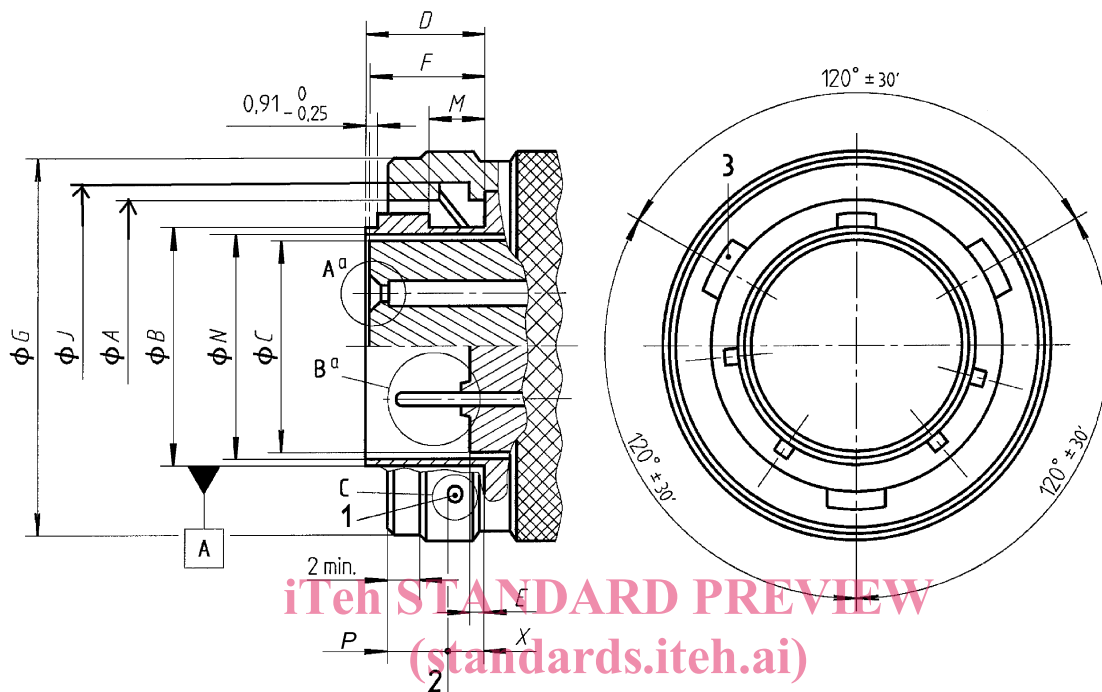

SIST EN 3646-01-2016 Coupling ring bayonet groove detail

<https://standards.iteh.ai/catalog/standards/sist/6ad3e63b-8b11-472c-ae77-3a3b22496fd9/sist-en-3646-001-2016>

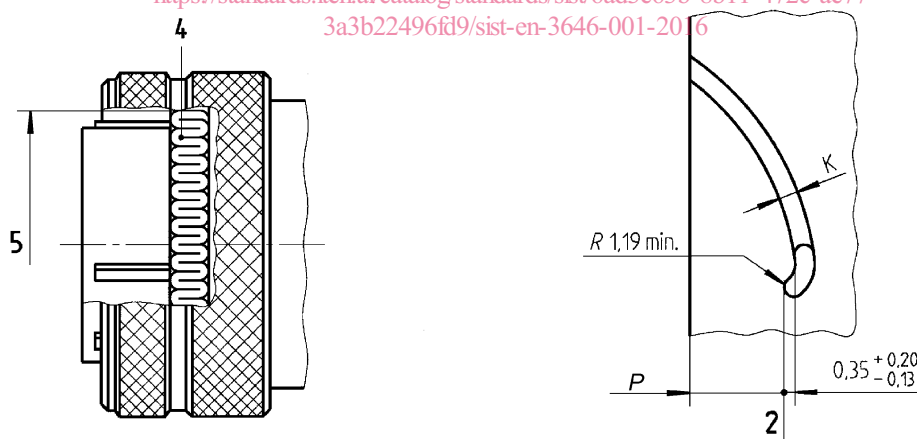

Key

- 1 Three mated connectors holes (design optional)
- 2 Reference. Locking point of the coupling ring.
- 3 Three bayonet grooves equally spaced within 0,13 with three holes equally spaced within 0,25 for visual inspection of coupling (see detail C).
- 4 Spring ground ring shall have at least six fingers per 25,4 mm of length.
- 5 Diameter L over spring finger
- a See Figure 1.

NOTE Diameter C is applicable to female insulators only

Figure 2 — Plug

Table 4 — Plug — Mating dimensions

Housing size	A	B	C	D	E	F	G	J	K	L	M	N	P	X
	+ 0,10 - 0,05	+ 0,05 - 0,10					max.	+ 0,13 - 0,15	+ 0,39 - 0,04	min.	max.	min.	max.	± 0,51
08	12,24	9,04	7,24	9,22 9,00	1,12 0,68	9,02 8,56	16,72	14,63	2,30	9,37	4,75	7,42	4,45	2,87
10	15,32	12,29	10,21				19,79	17,70		12,62		10,39		
12	19,35	15,14	13,11				23,70	22,12		15,60		13,28		
14	22,50	18,31	16,28				27,40	25,27		18,77		16,46		
16	25,68	21,49	19,46				30,53	28,44		21,95		19,61		
18	28,88	24,03	21,72				33,30	31,62		24,61		21,89		
20	32,03	27,20	24,89	10,78 10,56	2,70 2,26	10,59 10,13	37,45	34,79	3,50	27,79	5,54	25,07	4,75	3,86
22	35,20	30,38	28,07				40,45	37,97		30,96		28,22		
24	38,38	33,55	31,22				43,40	41,25		34,14		31,42		

6.3 Receptacle and plug polarization

See Figure 3, Figure 4 and Figure 5 and Table 5 and Table 6.

Dimensions and tolerances are in millimetres.

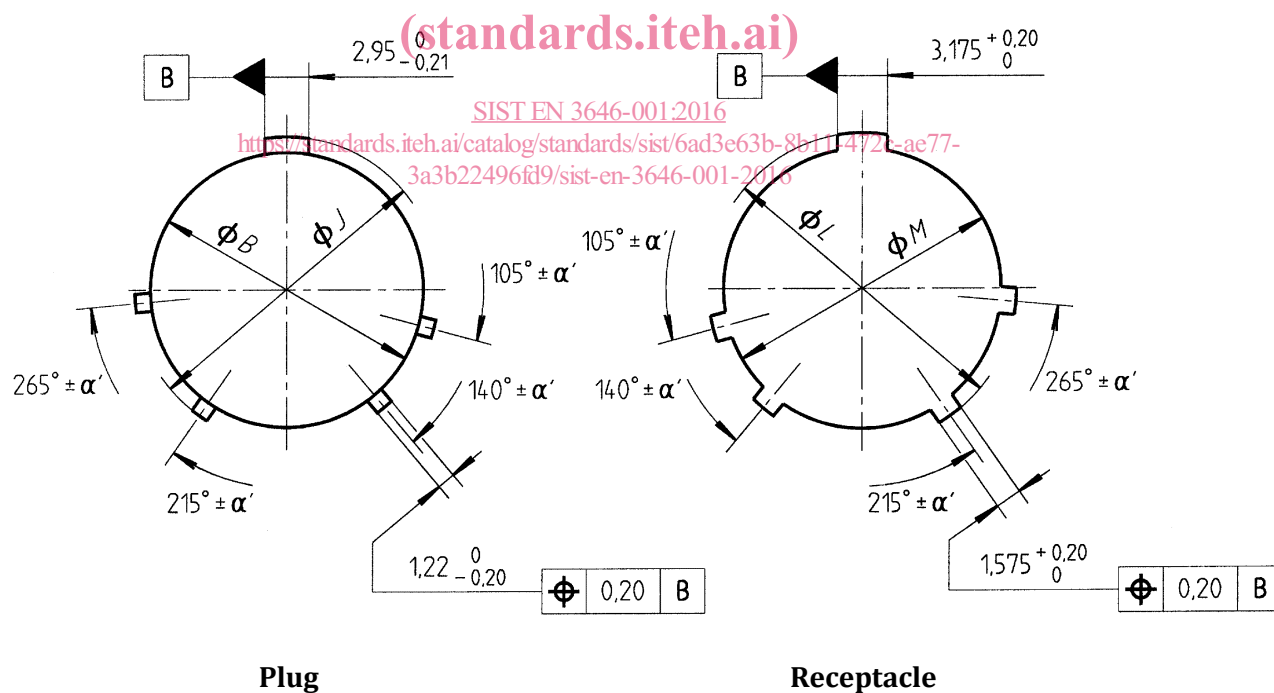

Figure 3 — Polarization