



SLOVENSKI STANDARD

SIST EN 572-7:2004

01-september-2004

BUXca Yý U
SIST EN 572-7:1999

GHY_`c`j`ghUj VUA`!`Cgbcj b]`dfc]nj cX]`n`bUf]!`_UW]Yj Y[Ug]]_UrbY[UghY_`U!`+`"XY`
p] bc`]b`VfYnj] bc`i`hcf`Ybc`ghY_`c`

Glass in Building - Basic soda lime silicate glass products - Part 7: Wired or unwired channel shaped glass

Glas im Bauwesen - Basiserzeugnisse aus Kalk-Natronsilicatglas Teil 7: Profilbauglas mit oder ohne Drahteinlage

Verre dans la construction - Produits de base verre de silicate sodo-calcique - Partie 7: Verre profilé armé ou non armé

Ta slovenski standard je istoveten z: EN 572-7:2004

ICS:

81.040.20 Steklo v gradbeništvu Glass in building

SIST EN 572-7:2004 en

iTeh STANDARD PREVIEW
(standards.iteh.ai)

[SIST EN 572-7:2004](#)

<https://standards.iteh.ai/catalog/standards/sist/206eaf4e-5bb9-4d81-a7b0-987ff797ef3b/sist-en-572-7-2004>

EUROPEAN STANDARD
NORME EUROPÉENNE
EUROPÄISCHE NORM

EN 572-7

June 2004

ICS 81.040.20

Supersedes EN 572-7:1994

English version

Glass in Building - Basic soda lime silicate glass products - Part 7: Wired or unwired channel shaped glass

Verre dans la construction - Produits de base: verre de silicate sodo-calcique - Partie 7: Verre profilé armé ou non armé

Glas im Bauwesen - Basiserzeugnisse aus Kalk-Natronsilicatglas Teil 7: Profilbauglas mit oder ohne Drahteinlage

This European Standard was approved by CEN on 1 April 2004.

CEN members are bound to comply with the CEN/CENELEC Internal Regulations which stipulate the conditions for giving this European Standard the status of a national standard without any alteration. Up-to-date lists and bibliographical references concerning such national standards may be obtained on application to the Central Secretariat or to any CEN member.

This European Standard exists in three official versions (English, French, German). A version in any other language made by translation under the responsibility of a CEN member into its own language and notified to the Central Secretariat has the same status as the official versions.

CEN members are the national standards bodies of Austria, Belgium, Cyprus, Czech Republic, Denmark, Estonia, Finland, France, Germany, Greece, Hungary, Iceland, Ireland, Italy, Latvia, Lithuania, Luxembourg, Malta, Netherlands, Norway, Poland, Portugal, Slovakia, Slovenia, Spain, Sweden, Switzerland and United Kingdom.

[SIST EN 572-7:2004](https://standards.iteh.ai/catalog/standards/sist/206eaf4e-5bb9-4d81-a7b0-987ff797ef3b/sist-en-572-7-2004)

<https://standards.iteh.ai/catalog/standards/sist/206eaf4e-5bb9-4d81-a7b0-987ff797ef3b/sist-en-572-7-2004>



EUROPEAN COMMITTEE FOR STANDARDIZATION
COMITÉ EUROPÉEN DE NORMALISATION
EUROPÄISCHES KOMITEE FÜR NORMUNG

Management Centre: rue de Stassart, 36 B-1050 Brussels

Contents

	page
Foreword.....	3
1 Scope	4
2 Normative references	4
3 Terms and definitions	4
4 Dimensional requirements.....	5
4.1 Method of measurement	5
4.1.1 Width, B , and height of flange, d	5
4.1.2 Length, H	5
4.1.3 Thickness, c	6
4.1.4 Flange deviation.....	6
4.1.5 Squareness of cut.....	6
4.1.6 Wire inlay	6
4.2 Tolerances	6
4.2.1 Width, B , height of flange, d , and thickness c	6
4.2.2 Length	6
4.2.3 Flange deviation.....	7
4.2.4 Squareness of cut.....	7
4.2.5 Wire inlay	7
5 Quality requirements	7
5.1 General.....	7
5.2 Methods of observation and measurement.....	7
5.2.1 Visual faults	7
5.2.2 Wire faults.....	7
5.3 Acceptance levels.....	8
5.3.1 Visual faults	8
5.3.2 Wire faults.....	8
6 Designation	8
Bibliography	9

iTeh STANDARD PREVIEW
(standards.itech.ai)

[SIST EN 572-7:2004](https://standards.itech.ai/catalog/standards/sist/en-572-7-2004)

[https://standards.itech.ai/catalog/standards/sist/206ca41c-5bb9-4d81-a7b0-](https://standards.itech.ai/catalog/standards/sist/206ca41c-5bb9-4d81-a7b0-9871177c13b0/sist-en-572-7-2004)

[9871177c13b0/sist-en-572-7-2004](https://standards.itech.ai/catalog/standards/sist/206ca41c-5bb9-4d81-a7b0-9871177c13b0/sist-en-572-7-2004)

Foreword

This document (EN 572-7:2004) has been prepared by Technical Committee CEN /TC 129 "Glass in Building", the secretariat of which is held by IBN.

This European Standard shall be given the status of a national standard, either by publication of an identical text or by endorsement, at the latest by December 2004, and conflicting national standards shall be withdrawn at the latest by December 2004.

This document supersedes EN 572-7:1994.

This document has been prepared under a mandate given to CEN by the European Commission and the European Free Trade Association, and supports essential requirements of EU Directive(s).

This European Standard "Glass in building – Basic soda lime silicate glass products" consists of the following parts:

- | | |
|----------|--|
| EN 572-1 | Definitions and general physical and mechanical properties |
| EN 572-2 | Float glass |
| EN 572-3 | Polished wired glass |
| EN 572-4 | Drawn sheet glass |
| EN 572-5 | Patterned glass |
| EN 572-6 | Wired patterned glass |
| EN 572-7 | Wired or unwired channel shaped glass |
| EN 572-8 | Supplied and final cut sizes |
| EN 572-9 | Evaluation of conformity/Product standard |

According to the CEN/CENELEC Internal Regulations, the national standards organizations of the following countries are bound to implement this European Standard: Austria, Belgium, Cyprus, Czech Republic, Denmark, Estonia, Finland, France, Germany, Greece, Hungary, Iceland, Ireland, Italy, Latvia, Lithuania, Luxembourg, Malta, Netherlands, Norway, Poland, Portugal, Slovakia, Slovenia, Spain, Sweden, Switzerland and United Kingdom.

EN 572-7:2004 (E)**1 Scope**

This Part of this European Standard specifies dimensional and minimum quality requirements (in respect of visual and wire faults) for channel shaped glass, as defined in EN 572-1, for use in building.

This Part of this standard covers channel shaped glass supplied in stock sizes and final cut sizes.

2 Normative references

This European Standard incorporates by dated or undated references, provisions from other publications. These normative references are cited at the appropriate places in the text, and the publications are listed hereafter. For dated references, subsequent amendments to or revisions of any of these publications apply to this European Standard only when incorporated in it by amendment or revision. For undated references the latest edition of the publication referred to applies (including amendments).

EN 572-1:2004, *Glass in building — Basic soda lime silicate glass products — Part 1: Definitions and general physical and mechanical properties*

3 Terms and definitions

For the purposes of this European Standard, the terms and definitions given in EN 572-1:2004 and the following apply.

3.1**patterned channel shaped glass**

channel shaped glass with one patterned surface. A number of different patterns are available

3.2**wired channel shaped glass**

channel shaped glass which has a wire inlay in the web, i.e. across the width, B , which runs in the direction of the length, H . Additional wires may also be in the flanges

3.3**length, H , width, B , and flange height, d**

defined with reference to the direction of draw of the glass ribbon as shown in Figure 1. All corners are rounded

3.4**stock sizes**

glass delivered in the following sizes:

3.5**nominal length, H**

supplied in multiples of 250 mm

NOTE Maximum length, H , available: 7 000 mm.

3.6**nominal width, B**

range from 232 mm to 498 mm

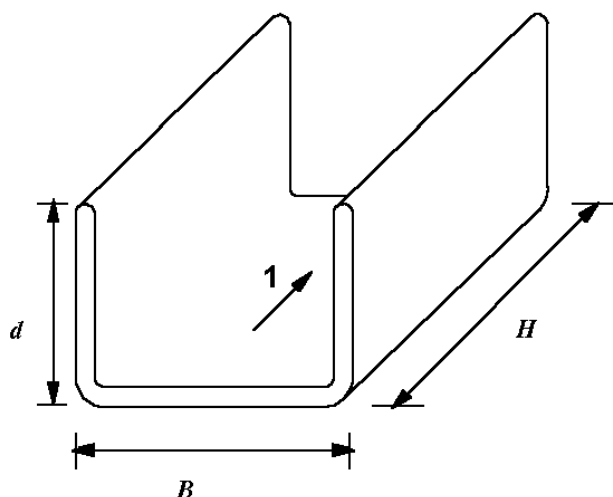

Figure 1 — Relationship between U-channel dimensions and direction of draw

Key

1 direction of draw

3.7

nominal height of flange, d
either 41 mm or 60 mm

iTeh STANDARD PREVIEW
(standards.iteh.ai)

NOTE Not all widths, B , are available with all flange heights, d .

[SIST EN 572-7:2004](https://standards.iteh.ai/catalog/standards/sist/206eaf4e-5bb9-4d81-a7b0-987ff797ef3b/sist-en-572-7-2004)

3.8

visual faults

faults that alter the visual quality of the glass. These include bubbles, ream, scratches and inclusions and where applicable wire faults

3.9

flange deviation

deviation, z , of flange from the vertical (see Figure 2)

3.10

wire faults

deviation of the wire, penetration of the glass surface by the wire or break in the wire in the body of the glass

3.11

wire deviation

deviation, y , of wire relative to a reference, e.g. line or straight edge, (see Figure 4)

4 Dimensional requirements

4.1 Method of measurement

4.1.1 Width, B , and height of flange, d

These are measured at both cut ends of the piece using a vernier calliper with an accuracy of 0,1 mm.

4.1.2 Length, H

This is measured at the centre of the web.

EN 572-7:2004 (E)

4.1.3 Thickness, c

The actual thickness is measured at both cut ends. Measurements, to an accuracy of 0,1 mm, are made in the centre of the web and flanges. Measurement should be made by means of an instrument of the plate gauge type with a diameter of $50 \text{ mm} \pm 5 \text{ mm}$.

4.1.4 Flange deviation

The deviation of the flange, z , from perpendicular to the web is determined with a right angle, as shown in Figure 2.

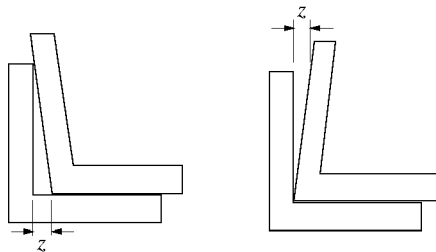

Figure 2 — determination of flange deviation

4.1.5 Squareness of cut

The out of squareness of the web and flanges is determined at both cut ends. It is measured relative to a plane perpendicular to the direction of draw of the glass at the intersection of the centre line of the web and of the cut edge (see Figure 3). The deviation of the flange plane is measured.

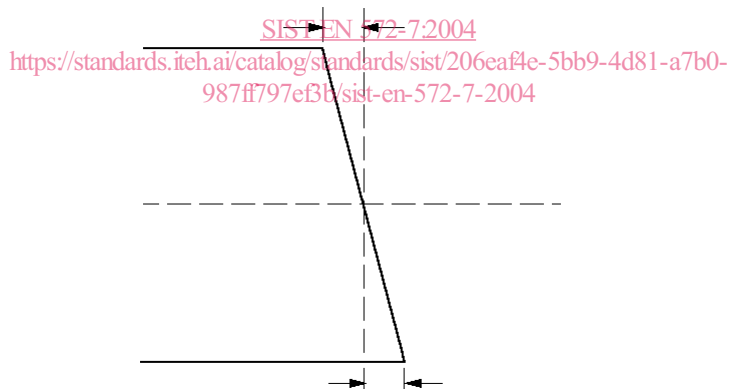

Figure 3 — Determination of squareness of cut

4.1.6 Wire inlay

The relationship between the width of the wire inlay, in the web, and the width, B , of the web should be obtained by measurement. The actual distance between adjacent wires should be measured together with any variation in the spacing. The diameter of the wire should be measured.

4.2 Tolerances

4.2.1 Width, B , height of flange, d , and thickness c

All measured values shall comply with Table 1.

4.2.2 Length

The tolerance on measured length, H , is $\pm 3,0 \text{ mm}$.

4.2.3 Flange deviation

The flange deviation, z , (see Figure 2) should not exceed 1,0 mm.

4.2.4 Squareness of cut

The deviation (see Figure 3) shall not exceed 3 mm.

4.2.5 Wire inlay

The wire inlay shall cover at least 75 % of the web width, B . The maximum distance between adjacent wires shall not exceed 35 mm. The allowable tolerance between adjacent wires is ± 6 mm. The diameter of the wire should be between 0,3 mm and 0,7 mm.

5 Quality requirements

5.1 General

One quality level is considered in this standard. This is determined by evaluation of the visual and wire faults.

5.2 Methods of observation and measurement

5.2.1 Visual faults

The piece of channel shaped glass to be examined is illuminated in conditions approximating to diffuse daylight and is observed in front of a white background.

Place the glass to be examined vertically in front of the screen. Arrange the point of observation 2 m from the glass, keeping the direction of observation normal to the glass surface.

NOTE The presence of bubbles, ream, scratches and inclusions.

Table 1 — Tolerances on nominal width, B , height of flange, d , and thickness c

Width, B (mm)		Height of flange, d mm		Thickness, c mm	
Nominal	Tolerance	Nominal	Tolerance	Nominal	Tolerance
232 to 498	$\pm 2,0$	41	$\pm 1,0$	6	$\pm 0,2$
232 to 331	$\pm 2,0$	60	$\pm 1,0$	7	$\pm 0,2$

5.2.2 Wire faults

A reference, e.g. line or straight edge, is placed parallel to the direction of the wires. The deviation, y , of the wire inlay in relation to this reference edge is measured (see Figure 4).

Any penetration of the glass surface by the wire is noted.

Any breaks in the wire are noted.