



Designation: D4125 – 05

# Standard Test Methods for Asphalt Content of Bituminous Mixtures by the Nuclear Method<sup>1</sup>

This standard is issued under the fixed designation D4125; the number immediately following the designation indicates the year of original adoption or, in the case of revision, the year of last revision. A number in parentheses indicates the year of last reapproval. A superscript epsilon ( $\epsilon$ ) indicates an editorial change since the last revision or reapproval.

## 1. Scope

1.1 These test methods cover the procedures for determining the asphalt content of samples of uncompacted bituminous mixtures (Test Method A), and of laboratory compacted specimens of bituminous mixtures (Test Method B) by examining a test sample with an apparatus that utilizes neutron thermalization techniques.

1.2 The values expressed in SI units are regarded as the standard. The inch-pounds equivalents may be approximate.

1.3 A precision and bias statement for Method B in this standard has not been developed at this time. Therefore, Method B should not be used for acceptance or rejection of a material for purchasing purposes.

1.4 *This standard does not purport to address all of the safety concerns, if any, associated with its use. It is the responsibility of the user of this standard to establish appropriate safety and health practices and determine the applicability of regulatory limitations prior to use.* See Section 6 and 8.4.2, 8.5.6, and Note 4, for specific hazards.

## 2. Referenced Documents

2.1 *ASTM Standards:*<sup>2</sup>

[C670 Practice for Preparing Precision and Bias Statements for Test Methods for Construction Materials](#)

[D75 Practice for Sampling Aggregates](#)

[D140 Practice for Sampling Bituminous Materials](#)

[D979 Practice for Sampling Bituminous Paving Mixtures](#)

[D1461 Test Method for Moisture or Volatile Distillates in Bituminous Paving Mixtures](#)

[D1559 Test Method for Resistance to Plastic Flow of](#)

[Bituminous Mixtures Using Marshall Apparatus](#)<sup>3</sup>

[D1561 Practice for Preparation of Bituminous Mixture Test Specimens by Means of California Kneading Compactor](#)

[D3387 Test Method for Compaction and Shear Properties of Bituminous Mixtures by Means of the U.S. Corps of Engineers Gyrotory Testing Machine \(GTM\)](#)

[D4013 Practice for Preparation of Test Specimens of Bituminous Mixtures by Means of Gyrotory Shear Compactor](#)

## 3. Significance and Use

3.1 These test methods are useful as a rapid, nondestructive technique for determination of asphalt content of bituminous mixtures.

3.2 These test methods are suitable for quality control and acceptance testing for construction and for research and development applications. The test method is used for determination of asphalt content only as it does not provide extracted aggregate for gradation analysis.

3.3 The non-destructive nature of the test allows repetitive measurements to be made on a single test sample for statistical analysis of test data.

3.4 These test methods determine the asphalt content of a test sample by comparing the measured asphalt content with previously established calibration data.

3.4.1 The asphalt content of a material expressed as a percentage, is the ratio of the mass of asphalt in a given mass of material to the total mass of the sample or to the mass of the solid material particles.

## 4. Interferences

4.1 The fundamental assumptions inherent in this test method are that the material under test is homogeneous and that hydrogen present is in the form of asphalt or has been otherwise accounted for in the calibration process.

4.2 Accurate results will be dependent upon proper calibration of the apparatus to the material being tested.

4.3 This apparatus measures the total amount of hydrogen in the sample including hydrogen present in the form of water.

<sup>1</sup> These test methods are under the jurisdiction of ASTM Committee D04 on Road and Paving Materials and is the direct responsibility of Subcommittee D04.25 on Analysis of Bituminous Mixtures.

Current edition approved June 1, 2005. Originally approved in 1983. Last previous edition approved in 2000 as D4125 – 94 (2000). DOI: 10.1520/D4125-05.

<sup>2</sup> For referenced ASTM standards, visit the ASTM website, [www.astm.org](http://www.astm.org), or contact ASTM Customer Service at [service@astm.org](mailto:service@astm.org). For *Annual Book of ASTM Standards* volume information, refer to the standard's Document Summary page on the ASTM website.

<sup>3</sup> Withdrawn.

Unless the test sample is free of water, such percentage must be determined in accordance with the provisions of Test Method D1461 and the percentage determined subtracted from the asphalt percentage as measured by the apparatus.

4.3.1 Alternatively, the sample may be dried to a constant mass in an oven at  $110 \pm 5^\circ\text{C}$  ( $230 \pm 9^\circ\text{F}$ ), thereby nullifying the need for the correction.

4.4 This apparatus may be sensitive to outside influences, therefore, any other source of neutron radiation shall be kept at least 10 m (30 ft) from the apparatus during use. The area around the apparatus shall be kept free of large amounts of hydrogenous material, such as water, plastics, or asphalt during use.

4.5 Moving the apparatus to a different location, even within the same laboratory, can cause a change in background radiation measurements. Also, if objects containing hydrogenous materials are moved in the area near the apparatus, the measurement counts may be affected. New background measurements shall be taken prior to use whenever background conditions have changed (see Section 10).

## 5. Apparatus

5.1 While exact details of construction for the apparatus may vary, the system shall consist of the following items:

5.1.1 *Neutron Source*—An encapsulated and sealed radioactive source such as americium/beryllium.

5.1.2 *Detectors*—Any type of thermal neutron detectors, such as helium-3 or boron trifluoride.

5.1.3 *Read-Out Instrument*, such as a scaler or a direct reading digital device calibrated in percent asphalt.

5.2 *Other Apparatus:*

5.2.1 *Stainless Steel Sample Pans*, of uniform size and mass.

5.2.2 *Balance*, capable of weighing to 20 kg (44 lb), readable to 1 g (0.0002 lbm).

5.2.3 *Oven*, capable of heating to  $177 \pm 3^\circ\text{C}$  ( $350 \pm 5^\circ\text{F}$ ).

5.2.4 *Straightedge*, steel, approximately 450 mm (18 in.) in length.

5.2.5 *Flat Plate*, metal or wood, having an area slightly larger than the sample pan. The metal plate shall have a minimum thickness of 10 mm ( $\frac{3}{8}$  in.). The wooden plate shall have a minimum thickness of 20 mm ( $\frac{3}{4}$  in.).

5.2.6 *Assorted Spoons and Mixing Bowls*.

5.2.7 *Thermometer* with a temperature range of 10 to  $250^\circ\text{C}$  (50 to  $482^\circ\text{F}$ ).

5.3 *Additional Apparatus for Test Method B:*

5.3.1 *Molded Laboratory Specimen Container*, (provided by instrument manufacturer) to allow for proper testing of laboratory compacted samples (see Fig. 1).

5.3.2 *Apparatus*, necessary to prepare compacted specimens as specified in Test Methods D1559, D1561, D3387, or Practice D4013.

## 6. Hazards

6.1 **Warning**—This equipment utilizes radioactive materials which may be hazardous to the health of the users unless proper precautions are taken. Users of this equipment must become completely familiar with possible safety hazards and with all applicable regulations concerning the handling and use

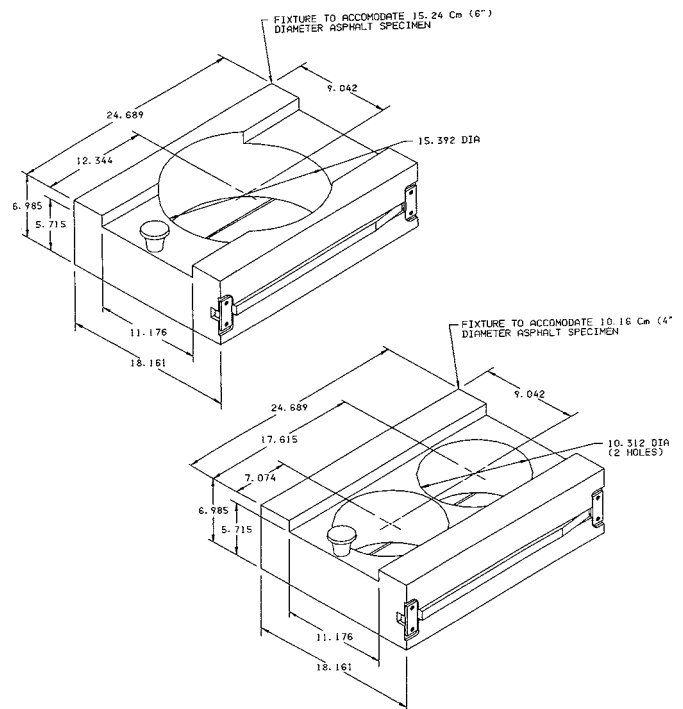

FIG. 1 Molded Laboratory Specimen-Containers Measurement Values in SI Units (CM)—Other Values for Reference Only

of radioactive materials. Effective user instructions together with routine safety procedures are a recommended part of the operation of this apparatus.

## 7. Sampling

7.1 Obtain random samples of aggregates in accordance with Practice D75.

7.2 Obtain random samples of freshly produced bituminous paving mixture in accordance with Practice D979.

7.3 Obtain random samples of bituminous materials in accordance with Practice D140.

## 8. Calibration

8.1 The test results obtained using this test method will be influenced by the types of aggregate, source, and grade of asphalt, and by the mix gradation. Accordingly, a calibration curve must be developed for each mix type and aggregate blend to be tested under this test method.

8.1.1 A new calibration curve shall be developed whenever there is a change in the source of asphalt or aggregate or a significant change in aggregate gradation.

8.1.2 A new calibration curve shall be established for new or repaired apparatus.

8.2 For Test Method A, calibrate the apparatus using the following procedures:

8.2.1 Sample the aggregates in accordance with 7.1 and blend the aggregates in the proper proportions. Obtain enough aggregate for a minimum of three samples. Approximately 30 kg (65 lb) will be required, and

8.2.2 Sample the bituminous materials in accordance with 7.3. Approximately 2.5 kg (5.5 lb) will be required.