**Connections for general use and fluid
power — Ports and stud ends with
ISO 228-1 threads with elastomeric or
metal-to-metal sealing —**

Part 1:

Threaded ports

iTeh STANDARD PREVIEW

*Raccordements pour applications générales et transmissions
hydrauliques et pneumatiques — Orifices et éléments mâles à filetage
ISO 228-1 à joint en élastomère ou étanchéité métal sur métal —*

ISO 1179-1:2007
Partie 1. Orifices filetés

[https://standards.iteh.ai/catalog/standards/sist/91aa3961-b95e-490a-a756-
affae23b8e76/iso-1179-1-2007](https://standards.iteh.ai/catalog/standards/sist/91aa3961-b95e-490a-a756-affae23b8e76/iso-1179-1-2007)



PDF disclaimer

This PDF file may contain embedded typefaces. In accordance with Adobe's licensing policy, this file may be printed or viewed but shall not be edited unless the typefaces which are embedded are licensed to and installed on the computer performing the editing. In downloading this file, parties accept therein the responsibility of not infringing Adobe's licensing policy. The ISO Central Secretariat accepts no liability in this area.

Adobe is a trademark of Adobe Systems Incorporated.

Details of the software products used to create this PDF file can be found in the General Info relative to the file; the PDF-creation parameters were optimized for printing. Every care has been taken to ensure that the file is suitable for use by ISO member bodies. In the unlikely event that a problem relating to it is found, please inform the Central Secretariat at the address given below.

iTeh STANDARD PREVIEW
(standards.iteh.ai)

ISO 1179-1:2007

<https://standards.iteh.ai/catalog/standards/sist/91aa3961-b95e-490a-a756-affae23b8e76/iso-1179-1-2007>



COPYRIGHT PROTECTED DOCUMENT

© ISO 2007

All rights reserved. Unless otherwise specified, no part of this publication may be reproduced or utilized in any form or by any means, electronic or mechanical, including photocopying and microfilm, without permission in writing from either ISO at the address below or ISO's member body in the country of the requester.

ISO copyright office
Case postale 56 • CH-1211 Geneva 20
Tel. + 41 22 749 01 11
Fax + 41 22 749 09 47
E-mail copyright@iso.org
Web www.iso.org

Published in Switzerland

Foreword

ISO (the International Organization for Standardization) is a worldwide federation of national standards bodies (ISO member bodies). The work of preparing International Standards is normally carried out through ISO technical committees. Each member body interested in a subject for which a technical committee has been established has the right to be represented on that committee. International organizations, governmental and non-governmental, in liaison with ISO, also take part in the work. ISO collaborates closely with the International Electrotechnical Commission (IEC) on all matters of electrotechnical standardization.

International Standards are drafted in accordance with the rules given in the ISO/IEC Directives, Part 2.

The main task of technical committees is to prepare International Standards. Draft International Standards adopted by the technical committees are circulated to the member bodies for voting. Publication as an International Standard requires approval by at least 75 % of the member bodies casting a vote.

Attention is drawn to the possibility that some of the elements of this document may be the subject of patent rights. ISO shall not be held responsible for identifying any or all such patent rights.

ISO 1179-1 was prepared by Technical Committee ISO/TC 131, *Fluid power systems*, Subcommittee SC 4, *Connectors and similar products and components*.

This first edition of ISO 1179-1, together with ISO 1179-2, ISO 1179-3 and ISO 1179-4, cancels and replaces ISO 1179:1981 which has been technically revised.

ISO 1179 consists of the following parts, under the general title *Connections for general use and fluid power — Ports and stud ends with ISO 228-1 threads with elastomeric or metal-to-metal sealing*:

- Part 1: Threaded ports
- Part 2: Heavy-duty (S series) and light-duty (L series) stud ends with elastomeric sealing (type E)
- Part 3: Light-duty (L series) stud ends with sealing by O-ring with retaining ring (types G and H)
- Part 4: Stud ends for general use only with metal-to-metal sealing (type B)

Introduction

In fluid power systems, power is transmitted and controlled through a fluid (liquid or gas) under pressure within a circuit. In general applications, a fluid may be conveyed under pressure. Components are connected through their threaded ports by fluid conductor connectors to tubes and pipes or to hose fittings and hoses.

Ports are an integral part of fluid power components, such as pumps, motors, valves, cylinders, etc.

For threaded ports and stud ends specified in new designs in hydraulic fluid power applications, ISO/TC 131/SC 4 recommends that the ISO 6149 series be used because these International Standards specify ports and stud ends with metric threads and O-ring sealing and because the sub-committee would like to help users by recommending one preferred system. ISO/TC 131/SC 4 further recommends that threaded ports and stud ends in accordance with the ISO 1179 series, ISO 9974 series and ISO 11926 series not be used for new designs in hydraulic fluid power applications; these International Standards will be maintained because they specify ports and stud ends that are currently used in hydraulic systems worldwide.

For threaded ports and stud ends specified in new designs in pneumatic fluid power applications, ISO/TC 131/SC 4 recommends that ISO 16030 be used, except where products are to interface with ISO 7-1 threads, because the sub-committee would like to help users by recommending one preferred system. ISO/TC 131/SC 4 further recommends that threaded ports and stud ends in accordance with the ISO 1179 series not be used for new designs in pneumatic fluid power applications; these International Standards will be maintained because they specify ports and stud ends that are currently used in pneumatic systems worldwide.

Significant testing over more than 30 years of use has confirmed the performance requirements of connection ends made from carbon steel. The stud end connections specified in ISO 1179 parts 2, 3 and 4 apply to connectors detailed in ISO 8434 parts 1, 2 and 4. [ISO 1179-1:2007](#)

<https://standards.iteh.ai/catalog/standards/sist/91aa3961-b95e-490a-a756-affae23b8e76/iso-1179-1-2007>

Connections for general use and fluid power — Ports and stud ends with ISO 228-1 threads with elastomeric or metal-to-metal sealing —

Part 1: Threaded ports

1 Scope

This part of ISO 1179 specifies dimensions for ports with ISO 228-1 threads for use with non-adjustable stud ends shown in ISO 1179-2, ISO 1179-3 and ISO 1179-4 and with adjustable stud ends shown in ISO 1179-3.

Ports in accordance with this part of ISO 1179 may be used:

- with ISO 1179-2 heavy-duty (S series) stud ends with type E sealing at working pressures up to 63 MPa (630 bar) and light-duty (L series) stud ends at working pressures up to 25 MPa (250 bar);
- with ISO 1179-3 light-duty (L series) stud ends with type G sealing at working pressures up to 31,5 MPa (315 bar), and with ISO 1179-3 light-duty (L series) adjustable stud ends with type H sealing at working pressures up to 20 MPa (200 bar); [ISO 1179-1:2007](https://standards.iteh.ai/catalog/standards/sist/91aa3961-b95e-490a-a756-0be2b8e7611c/iso-1179-1-2007)
- with ISO 1179-4 stud ends with type B sealing at working pressures up to 40 MPa (400 bar) for the S series, up to 25 MPa (250 bar) for the L series, and up to 10 MPa (100 bar) for the LL series,

except for the G2 size port, which in hydraulic fluid power systems is used mainly with accumulators and for which ISO 1179-2, ISO 1179-3 and ISO 1179-4 do not specify stud ends. The permissible working pressure depends upon size, materials, design, working conditions, application, etc.

Users of this part of ISO 1179 should ensure that there is sufficient material around the port to maintain the pressure.

NOTE The introduction of this part of ISO 1179 gives recommendations for ports and stud ends to be used for new designs in hydraulic and pneumatic fluid power applications.

2 Normative references

The following referenced documents are indispensable for the application of this document. For dated references, only the edition cited applies. For undated references, the latest edition of the referenced document (including any amendments) applies.

ISO 228-1, *Pipe threads where pressure-tight joints are not made on the threads — Part 1: Dimensions, tolerances and designation*

ISO 1179-2, *Connections for general use and fluid power — Ports and stud ends with ISO 228-1 threads with elastomeric or metal-to-metal sealing — Part 2: Heavy-duty (S series) and light-duty (L series) stud ends with elastomeric sealing (type E)*

ISO 1179-3, *Connections for general use and fluid power — Ports and stud ends with ISO 228-1 threads with elastomeric or metal-to-metal sealing — Part 3: Light-duty (L series) stud ends with sealing by O-ring with retaining ring (types G and H)*

ISO 1179-4, *Connections for general use and fluid power — Ports and stud ends with ISO 228-1 threads with elastomeric or metal-to-metal sealing — Part 4: Stud ends for general use only with metal-to-metal sealing (type B)*

ISO 5598, *Fluid power systems and components — Vocabulary*

3 Terms and definitions

For the purposes of this document, the terms and definitions given in ISO 5598 apply.

4 Dimensions

Ports shall conform to the dimensions shown in Figure 1 and given in Table 1.

Dimensions in millimetres;
surface roughness values in micrometres

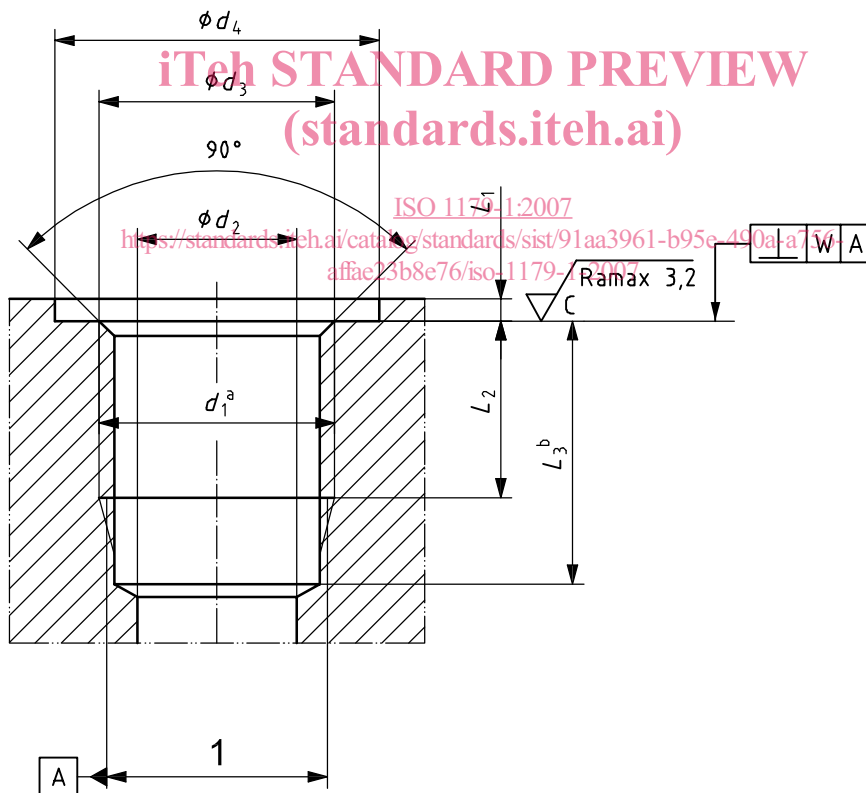

Key

- 1 thread pitch diameter
- ^a Thread.
- ^b Dimension L_3 applies when the tap drill cannot pass through entire boss.

Figure 1 — ISO 1179-1 port

Table 1 — Dimensions for ISO 1179-1 ports

Dimensions in millimetres

thread d_1^a	d_2 ref.	d_3		d_4^b min.		L_1 max.	L_2 min.	L_3^c min.	W
		nom.	tol.	Type N (narrow)	Type W (wide)				
G 1/8	4,5	9,8	+0,2 0	15	17,2	1	8,5	10,5	0,1
G 1/4	7,5	13,2		20	20,7	1,5	12,5	15,5	0,1
G 3/8	9	16,7		23	24,5	2	12,5	15,5	0,1
G 1/2	14	21		28	29,6	2,5	15	19	0,1
G 3/4	18	26,5		33	36,9	2,5	16,5	20,5	0,2
G 1	23	33,3	+0,3 0	41	46,1	2,5	19	24	0,2
G 1 1/4	30	42		51	54	2,5	21,5	26,5	0,2
G 1 1/2	36	47,9		56	60,5	2,5	22,5	27,5	0,2
G 2 ^d	47	59,7		69	73,28 to 73,53	3	26	31	0,2

^a Size and dimensions in accordance with ISO 228-1.

^b Type N corresponds to the spotface to be used with male stud end types B and E in ISO 1179-2 and ISO 1179-4. Type W corresponds to the spotface to be used with male stud end types G and H in ISO 1179-3.

^c Given tap drill depths require the use of a bottoming tap to produce the specified full thread lengths. Where standard taps are used, increase tap drill depths accordingly.

^d The G2 size port is used in hydraulic fluid power systems mainly in accumulators. ISO 1179-2, ISO 1179-3 and ISO 1179-4 do not specify stud ends for the G2 size port.

ISO 1179-1:2007

<https://standards.iteh.ai/catalog/standards/sist/91aa3961-b95e-490a-a756-affae23b8e76/iso-1179-1-2007>

5 Test methods

Ports shall be tested along with stud ends in accordance with the test methods and requirements given in ISO 1179-2, ISO 1179-3 and ISO 1179-4. For rated pressures lower than those specified in ISO 1179-2, ISO 1179-3 and ISO 1179-4, the test pressures shall be agreed upon between the manufacturer and user.

6 Designation of ports

The ports shall be designated by:

- “Port”;
- reference to this part of ISO 1179, i.e. ISO 1179-1;
- thread size;
- the letter symbol for the relevant spotface type. If no letter symbol is added, it is assumed that a type W (wide) spotface is used; otherwise, N shall be used to designate that a type N (narrow) spotface is used.

EXAMPLE A port in accordance with this part of ISO 1179 with a G 1/8 thread in accordance with ISO 228-1 and a narrow spotface is designated as follows:

Port ISO 1179-1 - G 1/8 - N

7 Identification statement (reference to this part of ISO 1179)

It is strongly recommended to manufacturers who have chosen to conform to this part of ISO 1179 that the following statement be used in test reports, catalogues and sales literature.

“Ports conform to ISO 1179-1, *Connections for general use and fluid power — Ports and stud ends with ISO 228-1 threads with elastomeric or metal-to metal sealing — Part 1: Threaded ports.*”

iTeh STANDARD PREVIEW (standards.iteh.ai)

[ISO 1179-1:2007](https://standards.iteh.ai/catalog/standards/sist/91aa3961-b95e-490a-a756-affae23b8e76/iso-1179-1-2007)

<https://standards.iteh.ai/catalog/standards/sist/91aa3961-b95e-490a-a756-affae23b8e76/iso-1179-1-2007>

Bibliography

- [1] ISO 7-1, *Pipe threads where pressure-tight joints are made on the threads — Part 1: Dimensions, tolerances and designation*
- [2] ISO 1101, *Geometrical Product Specifications (GPS) — Geometrical tolerancing — Tolerances of form, orientation, location and run-out*
- [3] ISO 1302, *Geometrical Product Specifications (GPS) — Indication of surface texture in technical product documentation*
- [4] ISO 6149-1, *Connections for hydraulic fluid power and general use — Ports and stud ends with ISO 261 metric threads and O-ring sealing — Part 1: Ports with truncated housing for O-ring seal*
- [5] ISO 6149-2, *Connections for hydraulic fluid power and general use — Ports and stud ends with ISO 261 metric threads and O-ring sealing — Part 2: Dimensions, design, test methods and requirements for heavy-duty (S series) stud ends*
- [6] ISO 6149-3, *Connections for hydraulic fluid power and general use — Ports and stud ends with ISO 261 metric threads and O-ring sealing — Part 3: Dimensions, design, test methods and requirements for light-duty (L series) stud ends*
- [7] ISO 8434-1, *Metallic tube connections for fluid power and general use — Part 1: 24° cone connectors*
- [8] ISO 8434-2, *Metallic tube connections for fluid power and general use — Part 2: 37° flared connectors*
- [9] ISO 8434-4, *Metallic tube connections for fluid power and general use — Part 4: 24° cone connectors with O-ring weld-on nipples*
<https://standards.iteh.ai/catalog/standards/sist/91aa3961-b95e-490a-a756-df0e23b8e765/iso-1179-1-2007>
- [10] ISO 9974-1, *Connections for general use and fluid power — Ports and stud ends with ISO 261 threads with elastomeric or metal-to-metal sealing — Part 1: Threaded ports*
- [11] ISO 9974-2, *Connections for general use and fluid power — Ports and stud ends with ISO 261 threads with elastomeric or metal-to-metal sealing — Part 2: Stud ends with elastomeric sealing (type E)*
- [12] ISO 9974-3, *Connections for general use and fluid power — Ports and stud ends with ISO 261 threads with elastomeric or metal-to-metal sealing — Part 3: Stud ends with metal-to-metal sealing (type B)*
- [13] ISO 11926-1, *Connections for general use and fluid power — Ports and stud ends with ISO 725 threads and O-ring sealing — Part 1: Ports with O-ring seal in truncated housing*
- [14] ISO 11926-2, *Connections for general use and fluid power — Port and stud ends with ISO 725 threads and O-ring sealing — Part 2: Heavy-duty (S series) stud ends*
- [15] ISO 11926-3, *Connections for general use and fluid power — Port and stud ends with ISO 725 threads and O-ring sealing — Part 3: Light-duty (L series) stud ends*
- [16] ISO 16030, *Pneumatic fluid power — Connections — Ports and stud ends*